

UNCLASSIFIED

AD NUMBER
AD862101
NEW LIMITATION CHANGE
TO Approved for public release, distribution unlimited
FROM Distribution authorized to U.S. Gov't. agencies and their contractors; Administrative/Operational Use; OCT 1969. Other requests shall be referred to Commanding Officer, Air Weather Service, Scott AFB, Il.
AUTHORITY
AFWA ltr, 19 Apr 2005

THIS PAGE IS UNCLASSIFIED

AD 562 101

ET MELVIN - Vice

# Technical Report 217



## METEOROLOGICAL RESOURCES AND CAPABILITIES IN THE '70's

Proceedings of the 5th AWS  
 Technical Exchange Conference  
 Air Force Academy  
 14-17 July 1969

*APPROVED FOR public release; distribution unlimited*  
 This Document is Subject to Special Export Controls  
 and Each Transmittal to Foreign Governments or  
 Foreign Nationals May Be Made Only With Approval  
 of Hq Air Weather Service

*GRAY, STANF  
 13 APR 05*

PUBLISHED BY  
 AIR WEATHER SERVICE (MAC)  
 UNITED STATES AIR FORCE  
 OCTOBER 1969

**Best  
Available  
Copy**

## FOREWORD

The Air Weather Service is pleased to make available to the aerospace-environmental community this report of the proceedings of the Fifth Technical Exchange Conference, held at the U. S. Air Force Academy, Colorado, on 14-17 July 1969. Its publication will serve a wider audience than could be accommodated at the Conference and will provide participants with an opportunity to study the stimulating presentations carefully at their leisure. In this way the information and coordination objectives of the Conference will be furthered.

The background and purpose of the Technical Exchange Conferences were described by Col Ralph G. Suggs in his keynote address. He also treated the importance of the theme of the Conference, "Meteorological Resources and Capabilities in the '70s." Twenty-four papers in all were given covering data-gathering systems, meteorological communications, computation and display, numerical weather-prediction capabilities, automation and applied weather forecasting, tropical meteorology, and weather modification--selected subjects crucial to the Air Weather Service in the '70s that also unquestionably concern the other weather services. The highlights of this Fifth Conference were summarized by Col Edward O. Jess who also acknowledged the various individuals who so ably assisted in the myriad of details in preparing arrangements and in running the meeting.

The conferees were warmly welcomed by Lt Gen Thomas S. Moorman, Superintendent of the Air Force Academy, who was Commander of the Air Weather Service in the late 1950s and who continues to be one of our field's staunchest supporters. At the banquet on the evening of 15 July, Dr. Archie Kahan, General Physical Scientist of the U. S. Bureau of Reclamation, regaled the diners with personal reminiscences (and slides) of his recent visit to the USSR and its weather-modification facilities. Dr. Hans K. Ziegler, Deputy for Science and Chief Scientist, U. S. Army Electronics Command, spoke at a special luncheon on 16 July of his remembrances of the inside story of early developments in the meteorological-satellite program; his remarks are included in this report.

All presentations were by invitation. They represented contributions from eminent specialists of the Army, Navy, Air Force, U. S. Coast Guard, Environmental Science Services Administration, Department of Agriculture, National Aeronautics and Space Administration, National Center for Atmospheric Research, RAND Corporation, Eastern Air Lines, Massachusetts Institute of Technology, Pennsylvania State University, and University of Nevada. A list of the over 200 distinguished attendees registered at the Conference also is included.

As Conference Coordinator and Moderator, I am most pleased to extend my personal thanks to all the speakers, attendees, and workers for their part in successfully fulfilling the mission of the Conference and making this report the valuable instrument for us that it is.

ROBERT D. FLETCHER  
DCS/Aerospace Sciences  
Hq Air Weather Service

8 August 1969

DISTRIBUTION: "F"  
Special

TABLE OF CONTENTS

	Page
SUMMARY OF WELCOMING ADDRESS - Lt General Thomas S. Moorman, Jr., Superintendent USAF Academy	1
KEYNOTE ADDRESS - Colonel Ralph G. Suggs, Vice Commander, Air Weather Service	2
SESSION I - Data Gathering Systems of the '70s (Chairman - Colonel Ralph Corbell, Air Weather Service)	
Data Gathering Systems of the '70s-A Survey - James Giraytys, U. S. Weather Bureau	5
Ground-Based Meteorological Observing Systems in the 1970's - Andrew S. Carten, Jr., Air Force Cambridge Research Laboratories	32
Meteorological Reconnaissance Systems of the 1970's - Richard G. Chappell, Air Weather Service	49
The Development of Meteorological Satellites in the United States and the Outlook for Future Sensing Systems - William Nordberg, Goddard Space Flight Center	53
National Data Buoy Development Project: A Status Report - J. A. Hodgman, U. S. Coast Guard	62
SESSION II - Meteorological Communication, Computation, and Display in the 1970's (Chairman - Lt Col Albert Romanick, AFGWC)	
Communications - Robert W. Fanning, Air Weather Service	69
AFWC Meteorological Display Techniques - Charles W. Cook, Air Force Global Weather Central	74
The Navy Weather Research Facility Program for the Development of a Functional Display and Presentation System - E. C. Kindle, Navy Weather Research Facility	84
On Limits in Computing Power - Willis H. Ware, RAND Corporation	98
The Army's Automatic Meteorological System - Donald M. Swingle, U. S. Army Electronics Command	102
LUNCHEON ADDRESS - Dr. Hans K. Ziegler, Deputy for Science and Chief Scientist, U. S. Army Electronics Command	111
SESSION III - Numerical Weather Prediction Capabilities in the '70s (Chairman - Major John S. Perry, Air Weather Service)	
Problems and Promises of Deterministic Extended-Range Forecasting - Joseph Smagorinsky, Geophysical Fluid Dynamics Laboratory, ESSA	115
Numerical Weather Prediction Capabilities in the '70s: A Personal View - Frederick G. Shuman, National Meteorological Center, Weather Bureau	116
The Real-Data Forecast Project at NCAR: A Progress Report - David P. Baumhefner, National Center for Atmospheric Research	123
Progress Report on Atmospheric Predictability - Edward N. Lorenz, Massachusetts Institute of Technology	138

	Page
SESSION IV - Automation and Applied Weather Forecasting (Chairman - Captain Max Eaton, Commander, Naval Weather Service Command)	
The Computer's Role in Weather Forecasting - William H. Klein, Techniques Development Laboratory, U. S. Weather Bureau	144
The Role of the Man in Weather Forecasting - J. J. George, Eastern Air Lines, Inc.	154
The Man-Machine Mix in Applied Weather Forecasting in the 1970s - L. W. Snellman, U. S. Weather Bureau Western Region	157
Application of Models to Forecasting Sensible Weather - Carl W. Kreitzberg, Pennsylvania State University and NCAR	166
SESSION V - Tropical Meteorology (Chairman - Mr. Marvin Lowenthal, Atmospheric Sciences Laboratory, U. S. Army Electronics Command)	
Survey of Progress and Plans in Tropical Meteorology Experiments - Edward J. Zipser, National Center for Atmospheric Research	178
Synoptic Analysis Models for the Tropics - R. H. Simpson, National Hurricane Center, Weather Bureau	189
The Use of Satellite Data in the Tropics - Ralph K. Anderson and Vincent J. Oliver, National Environmental Satellite Center, ESSA	201
Results and Plans of the AFCRL, University of Hawaii, 1 Weather Wing Tropical Meteorological Research Program - Thomas J. Keegan, Air Force Cambridge Research Laboratories	209
SESSION VI - Weather Modification (Chairman - Colonel Jacob Accola, Air Weather Service)	
Air Weather Service and Weather Modification - Thomas A. Studer, Air Weather Service	225
Lightning Suppression - Donald M. Fuquay, U. S. Department of Agriculture, Forest Service	228
Hail Suppression in the Seventies - Guy G. Goyer, National Center for Atmospheric Research	235
Precipitation Augmentation - Patrick Squires, Laboratory of Atmospheric Physics, Desert Research Institute, University of Nevada	244
SUMMARY COMMENTS - Colonel Edward O. Jess, Director of Aerospace Services, Air Weather Service	247

Index of Authors

Anderson, Ralph K.	201	Lorenz, Edward N.	138
Baumhefner, David P.	123	Moorman, Thomas S. Jr.	1
Carten, Andrew S. Jr.	32	Nordberg, William	53
Chappell, Richard G.	49	Oliver, Vincent J.	201
Cook, Charles W.	74	Shuman, Frederick G.	116
Fanning, Robert W.	69	Simpson, R. H.	189
Fuquay, Donald M.	228	Smagorinsky, Joseph	115
George, J. J.	154	Snellman, L. W.	157
Giraytys, James	5	Squires, Patrick	244
Goyer, Guy G.	235	Studer, Thomas A.	225
Hodgman, J. A.	62	Suggs, Ralph G.	2
Jess, Edward O.	247	Swingle, Donald M.	102
Keegan, Thomas J.	209	Ware, Willis H.	98
Kindle, E. C.	84	Ziegler, Hans K.	111
Klein, William H.	144	Zipser, Edward J.	178
Kreitzberg, Carl W.	166		

LIST OF ATTENDEES

Colonel Jacob Accola - Hq Air Weather Service (AWVPS)  
Lt Col Wm C. Anderson - Hq Air Weather Service (AWODC)  
Mr. Tomio Asai - National Center for Atmospheric Research  
Major Gary D. Atkinson - Hq Air Weather Service (AWVAS)  
Dr. Morton L. Barad - Air Force Cambridge Research Laboratories  
Mr. Paul F. Barritt - NASA Headquarters  
Mr. David P. Baumhefner - National Center for Atmospheric Research  
Cndr L. R. Bechelmayer, USN - Fleet Numerical Weather Central  
Major B. V. Benediction (RCAF) - 4 Weather Wing  
Mr. Carl Roetger - NASA, Wallops Island, Va  
Capt Shirley E. Boselly, 3345 Technical School  
Lt Col Nick L. Bradshaw - SAES-OJCS  
Lt Col John C. Brown - 9 Wea Recon Wg  
Dr. John A. Brown, Jr. - ESSA/Weather Bureau  
Lt Col Harold H. Brownfield - Hq Air Weather Service (AWXDC)  
Dr. C. E. Buell - Kaman Nuclear  
Dr. R. C. Bundgaard - Kaman Nuclear  
Mr. Richard C. Burriss - Kaman Nuclear  
Mr. Edward M. Carlstead - ESSA/Weather Bureau Pacific Region  
Mr. Thomas R. Carr - Geophysics Division, Code 3251, Pacific Missile Range  
Mr. Andrew S. Carten, Jr. - Air Force Cambridge Research Laboratories  
Major R. G. Chappell - Hq Air Weather Service (AWMDC)  
Major Richard L. Chapple - 9 Wea Recon Wg  
Lt Col James F. Church - Air Force Cambridge Research Laboratories  
Lt Col Charles W. Cook - 2 Wea Sq  
Col Ralph P. Corbell - Hq Air Weather Service (AWODC)  
Lt Cndr W. N. Cottrell - FWC, Suitland, Md.  
Lt Col W. P. Cramer - OL 5, 6 Wea Wg  
TSgt J. W. Crump - Hq Air Weather Service (AWVAS)  
Capt Robert deMichaels - Air Force Academy  
Mr. V. J. Descamps - Hq Air Weather Service (AWVAS)



Mr. Marvin Diamond, Atmospheric Sciences Lab, White Sands P. G.  
Mr. Edward D. Mieser - U. S. Weather Bureau, Anchorage, Alaska  
Capt John Diercks - Hq Air Weather Service (AWVAS)  
Lt Col C. T. Driskell - 4 Weather Wing  
Mr. Carlos R. Dunn - Weather Bureau Eastern Region  
Capt M. A. Eaton - Commander, Naval Weather Service Command  
Mr. Max Edelstein - Naval Weather Service Command  
Lt Col Gordon C. Edgar - 4 Weather Wing (O)  
Lt Col Daniel Englander - 4 Weather Wing  
Mr. Clarence Everson - 4 Weather Wing  
Mr. Bryan G. Falzgraf - 7 Weather Wing (V)  
Major Robert Fanning - Hq Air Weather Service (AWODC)  
Mr. William Finley - 6 Weather Wing  
Dr. Robert D. Fletcher - Hq Air Weather Service (AWVDC)  
Maj Eugene Frey - FTD (TDPTR-4)  
Mr. Donald M. Fuquay - U. S. Department of Agriculture, Forest Service, Missoula, Mt.  
Mr. Joseph G. Gamble - Federal Aviation Administration  
Brig Gen Joseph J. George, USAF (ret) - Director of Meteorology, Eastern Air Lines, Inc.  
Dr. Joseph Gerrity - National Meteorological Center  
Mr. James Gillespie - USA - CDCCEA, Ft Monmouth, NJ  
Mr. James Giraytys - ESSA/Weather Bureau  
Dr. Harry R. Glahn - Techniques Development Lab, ESSA/Weather Bureau  
Dr. Guy O. Goyer - National Center for Atmospheric Research  
Mr. Marshall F. Grace - ESSA Weather Bureau, Denver, CO  
Lt Col W. B. Haidler - U S Air Force Academy  
Major Edward Hanrahan - U S Air Force Academy  
Capt Phillips Hanson - 4 Weather Wing  
Major Donald C. Hansen - Hq Air Weather Service (AWVAS)  
Mr. V. S. Hardin - Hq Air Weather Service (AWVAR)  
Capt Frank Hartranft - 4 Weather Wing  
Capt Larry R. Heaton - Hq Air Weather Service (AWVAS)  
Major Kenneth V. Heuer - 5 Weather Wing (V)

Mr. Paul Hexter - ESSA Weather Bureau  
Major Joseph Hope - 6 Weather Wing  
Mr. John Hostetler - Det 7, 4 Weather Wing  
Mr. Donald C. House - Environmental Science Services Administration  
Lt Col Ben H. Houston - U S Air Force Academy  
Capt John M. Huck - 7 Weather Wing (V)  
Col H. R. Jackson - U S Army Field Artillery School  
Maj Norman F. Jacobs - SAES - OJCS  
Lt Col James G. Howcroft - OL 10, Hq AWS  
Mr. Roy Jenne - National Center for Atmospheric Research  
Col Edward O. Jess - Hq Air Weather Service (AWVAS)  
Dr. Archie M. Kahan - Bureau of Reclamation, Denver Federal Center  
Dr. Akira Kasahara - National Center for Atmospheric Research  
Mr. Thomas J. Keegan - Air Force Cambridge Research Laboratories  
Mr. Robert Kelsey - U S Army Field Artillery Agency  
Mr. Wm. C. Kincannon - Naval Air Systems Command  
Dr. Earl C. Kindle - Naval weather Research Facility  
Dr. William H. Klein - Techniques Development Laboratory, Weather Bureau  
Mr. Sterling J. Knight - USAE Waterways Experiment Station  
Capt R. K. Kooser - Washington Office, Hq Air Weather Service  
Col Alexander Kouts - Hq USAF (AFRDS/CCG-QMS)  
Maj Earl R. Kreins - Hq USAF (AFRDS/CCG-QMS)  
Dr. Carl W. Kreitzberg - Pennsylvania State University  
Mr. David A. Lawson, Jr. - U. S. Army Advanced Material Concepts Agency  
Lt Col Lloyd Steubinger - USAF ETAC  
Prof E. N. Lorenz - Massachusetts Institute of Technology  
Mr. Marvin Lowenthal - Atmospheric Sciences Laboratory  
Lt Col D. H. Lufkin - 4 Weather Wing  
Dr. Joseph G. Lundholm, Jr. - Apollo Applications Program, NASA Headquarters  
Mr. Jerry R. Lundien - USAE Waterways Experiment Station  
Mr. John Masterson - National Center for Atmospheric Research  
Capt George T. Matteson - 4 Weather Wing

Maj Wilbert G. Maunz - 6 Weather Wing  
Mr. Harold McCrabb - ESSA/Weather Bureau  
Mr. Donald F. Moore - Environmental Science Services Administration  
Mr. Paul L. Moore, Weather Bureau Southern Regional Headquarters  
Lt Gen Thomas S. Moorman - Superintendent, U S Air Force Academy  
Dr. Frank Murray - RAND Corporation  
Mr. Henry Newhouse - ESSA/ Systems Development Office  
Mr. William D. Ohmstedt - U S Army Electronics Command  
Mr. Vincent J. Oliver - Chief, Applications Group, National Environmental Satellite Center  
Mr. Stanley E. Pearse - Hq Air Weather Service (AWVDC)  
Lt Col Harry P. Pedersen - 3 Weather Wing  
Maj John S. Perry - Hq Air Weather Service (AWVAS)  
Mr. Melvin H. Rajala - 4 Weather Wing  
Dr. R. R. Rapp - RAND Corporation  
Capt B. A. Read - USA SACCOM Agency  
Maj Malcolm Reid - USACDCCEA, Fort Monmouth, NJ  
Lt Col Glenn C. Reiter - 2 Weather Wing  
Mr. Joseph Restivo - 4 Weather Wing  
Capt Thomas L. Rish - 5 Weather Wing  
Mr. C. E. Roache - Office of the Federal Coordinator for Meteorology  
Mr. Charles F. Roberts - Weather Bureau  
Lt Col Albert M. Romanick - 2 Weather Squadron  
Lt Col Glenn Rumley - 1 Weather Wing  
Lt Col Robert Sabin - 4 Weather Wing  
Mr. Vincent V. Salomonson - Planetary Radiations Br, Goddard Space Flight Center  
Col Robert W. Sanderson - Commander, USAF ETAC  
Lt Col Gordon Schmal - 4 Weather Wing  
Dr. William E. Shenk - Planetary Radiations Br, Goddard Space Flight Center  
Dr. Frederick G. Shuman - Director, National Meteorology Center  
Mr. Joseph A. Siderman - USACDCCEA  
1st Lt Gerald J. Sikula - Det 1, 4 Weather Wing  
Dr. Robert H. Simpson - U S Weather Bureau, National Hurricane Center

Dr. Joseph Smagorinsky - Director, Geophysical Fluid Dynamics Laboratory, ESSA  
Mr. Orvel E. Smith - National Aeronautics and Space Administration  
Lt Col Wm E. Smurro - Hq Air Weather Service (AWOAO)  
Mr. Leonard W. Snellman - Western Region, U S Weather Bureau  
Dr. Kenneth Spengler - Brig Gen, USAFR - Executive Secretary, American Meteorological Society  
Mr. John F. Spurling - Met Projects and Systems Sec, Instrumentation Development Br, Range  
Engineering Division  
Dr. Patrick Squires - Desert Research Institute, University of Nevada  
CWO3 C. E. Stephenson - US Army Field Artillery School  
Mr. Robert G. Stone - Hq Air Weather Service (AWVAS/TF)  
Mr. Donald R. Stribling - Kaman Nuclear  
Major Thomas A. Studer - Hq Air Weather Service (AWVPS)  
Col Ralph G. Suggs - Vice Commander, Air Weather Service  
Maj D. G. Sullins - Office of Aerospace Research  
Dr. Donald Swingle - U S Army Electronics Command  
Mr. Ralph Talley - USACDC (CDCMR-E), Ft Belvoir, VA  
Lt Col Ray T. Telfer - 3 Weather Wing  
Mr. Robert W. Titus - Air Resources Laboratory  
Major Ronald Tudor - Air Force Academy  
Mr. Gustav H. Wendt - 4 Weather Wing  
Dr. Willis Ware - Department of Computer Sciences, RAND Corporation  
Dr. Willis Webb - Atmos. Sci. Lab, White Sands Missile Range  
Mr. Bill Weigh - National Center for Atmospheric Research  
Mrs Frances Whedon - Army Research Office, Dept of the Army  
Dr. Fred D. White - National Science Foundation  
Lt Col E. A. Wiberg, Jr. - OL 4, 6 Weather Wing  
Mr. David Williamsen - National Center for Atmospheric Research  
Maj William V. Yelton - 9 Weather Recon Wing  
Mr. Murray J. Young - USAF ETAC  
Captain R. A. Zettel, USNR - National Data Buoy Development Project  
Dr. Hans K. Ziegler - Chief Scientist, U S Army Electronics Command  
Dr. Edward Zipser - National Center for Atmospheric Research

SUMMARY OF WELCOMING ADDRESS

Lt. Gen. Thomas S. Moorman  
Superintendent, U. S. Air Force Academy

General Moorman began by extending a welcome to the conferees on behalf of the Air Force Academy and its staff. He then briefly summarized the Academy's mission, history, and present program.

He felt that the Conference theme — Meteorological Resources and Capabilities of the 70's — was both appropriate and challenging. In today's increasingly complex and technological world, the difficult but inescapable task of planning rationally for the future was attracting ever more attention from businessmen, economists, and scientists. He wished the conference every success in plotting the future course of the atmospheric sciences — a forecast on forecasting, as it were.

Education in meteorology was of great concern to General Moorman both in regard to the USAF Academy and in his capacity as a member of the American Meteorological Society Commission on Meteorological Education. We must, he stated, ensure that a fair share of our nation's bright young men enter professional careers in the environmental sciences. Since the Air Force operates in the aerospace environment, it was essential that all students at the Academy acquire a sound understanding of the science of this environment. To this end, the Academy has established four courses in atmospheric science and hopes that some future USAF officers will thereby be motivated to pursue careers in this field.

General Moorman concluded by again wishing the Conference every success in its endeavors and expressing his eagerness to review its results.

KEYNOTE ADDRESS  
FOR THE  
1969 METEOROLOGICAL TECHNICAL EXCHANGE CONFERENCE

Ralph G. Suggs, Colonel, USAF  
Vice Commander  
Air Weather Service (MAC)

It is indeed a pleasure for me to address this distinguished group, gathered here at the end of America's first century of organized weather forecasting. This is, as you know, the fifth in the series of technical conferences which began in 1965.

We originally conceived these meetings as a vehicle to coordinate environmental research within our own Air Weather Service family. We soon found, however, that we could not rationally plan our own activities without an up-to-date understanding of the work of others.

So, we began to broaden the scope of these conferences to include contributions from the other military weather services and, later, from the civilian meteorological community. Participation in the conferences has grown steadily, and the scope of the meetings has enlarged until they now include many of the environmental sciences. Clearly, this type of ecumenical gathering has filled a real need.

Each of our past meetings has had a somewhat different central theme -- and this is good. The developing role of the environmental sciences is a many-faceted one. Our purpose at this year's meeting is to look forward into the coming decade. During this conference, we will be addressing our attention to 'Meteorological Resources and Capabilities in the 70s.'

I will not try to steal the thunder, if you will, of the eminently well-qualified soothsayers gathered here; for tomorrow's scientific advances are even harder to predict than tomorrow's weather. Instead, I would like to offer some reflections on the past development of our environmental sciences and to explore some hopes for their future.

1970 will not only herald the dawn of a new decade for progress; it will also mark the end of an eventful century for the atmospheric sciences. For it was in 1870 that the Signal Corps first ventured to prepare daily forecasts of the most changeable element in our environment -- the weather. We should also note that next year is the fiftieth anniversary of the American Meteorological Society.

Those first brave forecasts of almost a century ago were based on little more than Ben Franklin's observation that weather moved from west to east. In later years, our thinking was revolutionized by the polar-front theory. Still later, better observations permitted adequate three-dimensional analysis of the atmosphere. But most significantly, both theory and observation led to a better understanding of our ocean of air. These advances have already led meteorologists to plan for the 1970's exciting global experiments in observation and analysis of the world's weather.

However, the atmospheric sciences have not limited themselves to the narrow confines of our planet's thin skin of air. As our military and civilian customers ventured into uncharted environments, they turned to the meteorologists to find pilots. And so, in this hall today, we find scientists who deal with the atmosphere of the sun rather than that of the earth, and others who are more concerned with our own atmosphere's electrons than with its raindrops.

This twofold growth in the depth and scope of our concerns has been accompanied by a corresponding growth in our profession. A gathering such as this would have been impossible a few generations ago. Meteorologists were a rare breed, and few other professionals would have considered themselves atmospheric scientists. But our nation

has responded to the growing challenges and opportunities of the environment by educating new generations of versatile scientists.

The demands of World War II brought thousands of young scientists with diverse backgrounds into operational meteorology. This trend has continued; even today, we find that most practicing meteorologists started their careers in other branches of science. But recent years have seen a new growth in education in the atmospheric sciences, as evidenced by the number of new university departments which have blossomed across the land. Thus, today our ranks are being swelled by a new crop of enthusiastic young scientists whose primary specialization is meteorology.

As we await the dawn of the seventies, I predict that this cadre of dedicated and able environmental scientists will be our greatest asset. And, it is clearly appropriate to speak of this diverse group in collective terms, for today we recognize a common concern in the all-encompassing environment.

In this decade, man has first viewed his homeland from the vantage point of the moon. In a few days, we will first set foot on an alien body of the universe. From the standpoint of the stars, this momentous step is but a ferry operation from one planetary spaceship to another. On the earth, on the moon, or enroute from one to the other, the prime concern is for the environment of man and his tools. This is the thread that unites our diverse disciplines even more firmly.

And so, the history of our profession has been a story of innovation, growth, education, and an increasing recognition of the unity of the environmental sciences. I am personally proud of the leading role that the military services have played in this growth. I have already noted the Signal Corps' pioneering work in the infancy of meteorology. The military weather services were the first to attempt operational forecasts of severe weather, high-altitude winds, and clear-air turbulence. The foundations of radar meteorology were laid by military forecasters. And we must not forget that the adaptation of computers to weather forecasting was pioneered by the Joint Numerical Weather Prediction Unit.

This pioneering role was thrust upon us by the urgent needs of our military customers. The inherently competitive nature of the military mission inevitably forces military systems to challenge our environment and our knowledge. Military aircraft have blazed new trails across the sky and uncovered such new environmental phenomena as the jet stream and clear-air turbulence, and have brought us the problems of supersonic flight.

Today, space and missile systems pose environmental problems which tax our understanding of the earth's surroundings. Thus, in the Air Weather Service, we have stretched the word "weather" to the limit; our "weathermen" now deal with everything from the surface of the earth to the surface of the sun.

I am proud to recognize the many contributions of these "weathermen" to the nation's scientific capability. The spectacular growth of meteorology in the past quarter-century owes much to the huge meteorology training programs of World War II. In the years since then, the military services have continued to be the major educators for the atmospheric environmental sciences. The Air Weather Service, for example, has sent 2,500 young officers through basic meteorology training in the past ten years alone. In the same period, more than 600 of our more senior people have undertaken graduate studies in various fields of the environmental sciences. Thus, in the past decade we have trained and returned to civilian life more meteorologists than we now have on active duty.

While our personnel specialists bemoan the losses these figures imply, our loss in professional resources has been offset by the gains to the nation's scientific capabilities. The talented scientists from diverse backgrounds whom we have brought into the environmental sciences form a priceless national resource. The number of military alumni present here today attests to the value of this continuing educational program and certainly has contributed to the truly fine cooperation which exists between the military and civilian branches of our sciences.

I feel that one of the most important objectives of this series of conferences is to further this spirit of cooperation. As we look ahead together into the seventies, we cannot

foretell all of the problems that will face us. We can, however, forecast with confidence that we will face challenging new tasks. Both in our traditional fields of interest and in the new environments mankind will pioneer.

There will be more than enough work for all, regardless of academic specialty or organizational affiliation. And we can best tackle this work in a spirit of cooperation, sharing the skills of our diverse environmental sciences and the talents of our gifted scientists -- both in uniform and in mufti. I challenge this gathering to lay a firm foundation -- for a coming decade of unprecedented progress and cooperation in the environmental sciences. The road that led to the successes of today was built by the labors of our predecessors. In the same way, we must build new resources and capabilities as a bridge to the future. We "old men" of the environmental sciences must emulate the old man of a poem I unearthed the other day.

An old man, going a lone highway,  
Came at evening, cold and gray  
To a chasm, vast, and deep, and wide,  
Through which was flowing a sullen tide.  
The old man crossed in the twilight dim;  
The sullen stream had no fears for him;  
But he turned, when safe on the other side,  
And built a bridge to span the tide.  
"Old man," said a fellow pilgrim near,  
'You are wasting strength with building here;  
'Your journey will end with the ending day;  
'You never again must pass this way;  
'You have crossed the chasm, deep and wide --  
'Why build you the bridge at the eventide?'  
The builder lifted his old grey head:  
"Good friend, in the path I have come," he said,  
"There followeth after me today  
"A youth, whose feet must pass this way.  
"This chasm, that has been naught to me,  
"To that fair-haired youth may a pitfall be.  
"He, too, must cross in the twilight dim;  
"Good friend, I am building the bridge for him."



## DATA GATHERING SYSTEMS OF THE 70'S--A SURVEY

James Giraytys  
Weather Bureau  
U.S.A.

"The present is big with the future,  
the future might be read in the past,  
the distant is expressed in the near."

Leibnitz

The forecast is based on two premises: (1) "New" systems to be used in the 1970's are under development today, and (2) changes to the present networks will be evolutionary and not revolutionary. The data acquisition system of the 1970's will differ from today's system in two significant ways: Automation of the surface observation will be extensive and remote sensing, particularly from satellites, will augment or replace for some purposes the present rawinsonde systems. Global, long range forecasts will rely heavily on remote satellite sensing. Radiosonde observations will be made to 10 or 5 mb at only some 10-15 stations in the United States. Other stations will terminate soundings near 300 mb. Mesoscale and microscale, short range forecasts will be supported by networks of automatic stations in and around major cities as well as surface based remote, low level sounding systems. Mobile upper air stations will be available for seasonal use in the midwest and along the Gulf and Atlantic coasts. Buoys will provide data from coastal areas, but a network of deep ocean, meteorological buoys will not be realized during the decade. Quantitative radar data will be readily available over telephone circuits as will be computer prepared radar composites. Besides the technical problems involved, there are a number of managerial problems to be solved. Chief among these are standardization of observing techniques, network calibration, and the definition and application of data accuracy terminology. However, the foremost difficulty is the plethora of possible new observing systems compared to the funds available for research, development, and purchase. Circumstances dictate that network data requirements be thoroughly reviewed and priorities assigned on a national basis. Unfortunately, I find little overt action being taken to set such priorities.

### I. Introduction

Today, theoretical and practical work is being conducted across the board from indirect satellite sensors operating in the visible, infrared, microwave and radio frequencies to sub-miniature electronics. Yet, meteorologists have barely begun to exploit the advances being made in communications, automation, sensor electronics, and remote sensing. We must understand, however, that as we exploit new technology, we are constrained both by the residual value of existing equipment and the availability of money for new systems. Of necessity, the process of change will be evolutionary; and operational programs will continue to lag well behind research and development efforts.

When I accepted this assignment, I was asked to present a forecast of the meteorological data gathering systems likely to be in use during the 1970's. Let me begin by establishing some terms of reference which will limit my presentation to a manageable size. I intend to include only systems which, in my opinion, are applicable to broad problem areas, i.e., large programs as defined either in terms of absolute numbers of observations obtained or in the space and time coverage afforded. In setting the stage for the forecast, it will be necessary to consider the current research and development (R&D) programs being conducted around the world. This is patently impossible. Therefore, I will only consider representative programs which bear directly on the broad programs as defined above.

Any forecast is hazardous, and such a subjective one as this could be little more than a guess. However, we do have two solid pillars upon which to base the forecast. First, a system is in existence today; and changes will be made by adding to this system rather than by replacing it in toto. Second, the time required to budget for, install, and commission new equipment is long enough so that any new system to be used during the 1970's is likely to be under development today.

As an outline for this paper, let me pose three questions and answer them in turn:

1. What challenges will the data gathering system face in the 1970's?
2. What are we doing to improve the system?
3. What systems will be operational in the 1970's?

## II. Challenges to the Data Gathering System (...the distant is expressed in the near...)

**A. Nature of the Challenge.** The challenges facing meteorology are as diverse as the needs of the users of environmental data. Baum (1969) states that the major challenge today is to bring man into ecological balance with his world. Translated to the field of meteorology, this challenge means that we are faced with two major problems--the long range, global forecast and the short range, local forecast. Observations are important only to the extent that they are needed for forecasts. It is for this reason that the challenges to the observing program stem from forecast and service programs, which, in turn, arise because we are striving to attain an ecological balance with our environment.

**B. Global Forecasts.** Global forecasts will only become a reality through the efforts of people working under an international program--specifically, the World Weather Program. Davies (1969) points out that the World Weather Program sponsored by the World Meteorological Organization is an agenda for a global meteorological service incorporating new technology. The WWP has two major branches which are the World Weather Watch (WWW) and the Global Atmospheric Research Project (GARP) (Ashford, 1969). (The WWW includes Global Observations, Communication and Telecommunication systems.)

GARP is sponsored by governments through the WMO and by scientific institutions through the International Council of Scientific Unions. Just as the International Polar Years (1882-83 and 1932-33) and International Geophysical Year (1957-58) provided major stimuli to meteorology, GARP will stimulate advances in our observing capability. Not only will additional observing points be required, but such a global effort will require major improvements to existing techniques and an international standardization of equipment. To meet the challenge of standardization, the Commission for Instruments and Methods of Observation (CI-MO) has already begun comparisons to develop a reference radiosonde (Hinzpeter, 1969). An international comparison of raingages has been completed (Ciraytys and Heck, 1968). Efforts are underway to conduct a comparison of rocket sounding devices.

A question to be asked is what data requirements will be placed on the observing system as a result of GARP? A qualitative analysis (COSPAR, 1967) shows that in the adiabatic models then under development, the largest nonobservational source of error would be from diabatic heating processes (condensation, evaporation, heat transfer with land and water surface, etc.). For these models at the end of a 15-20 day forecast, the errors from neglecting diabatic heating are about the same or those from the following initial observational errors: Temperature, 1C; pressure, 3 mb; or wind, 2-3 m/s. Turned around, if the initial data errors exceed these amounts, the observational errors are larger than the most important errors in the model. Table 1 contains the accuracies for upper air data which were adopted in October 1968 by COSPAR Working Group IV as first priority for GARP.

Table 1. Upper Air Data Accuracies for the  
Global Atmospheric Research Project

Wind - 2 m/s	Horizontal Resolutions - 400 km
Temperature - 2C	Vertical Resolution - 20 mb once
Water Vapor - 10%	per day to 100 mb, globally
Pressure (reference level) 0.2%	

GARP is not the only global research effort to present challenges to our observing program. The UNESCO is sponsoring the Integrated Global Ocean Station System (IGOSS) through its Intergovernmental Oceanographic Commission (IOC). In fact, IGOSS is a "wet" GARP; and the two programs are closely allied. The ongoing Barbados Oceanographic and Meteorological Experiment (BOMEX) is a United States sponsored part of GARP and is aimed specifically at the problems of sea-air interactions. The Food and Agriculture Organization (FAO-UNESCO) is sponsoring the International Hydrologic Decade. The United States has proposed to the United Nations that it sponsor an International Decade of Ocean Exploration for the 1970's.

C. Local Forecasts. While major improvements have been made in long range forecasting due to a better modeling of the gross features of the atmosphere, only modest progress has been made in the improvement of local forecasts. For example, consider the general equation describing a change with time of a meteorological parameter:

$$\frac{dx}{dt} = \underbrace{\tilde{V}_t^{(1)}}_{\text{local change}} + \underbrace{\tilde{V}_t \cdot \nabla \tilde{V}_t^{(2)}}_{\text{advection}} + \underbrace{2\Omega \times \tilde{V}_t^{(3)}}_{\text{coriolis}} = \underbrace{\frac{1}{\rho} \nabla P^{(4)}}_{\text{pressure gradient}} - \underbrace{\nabla \Phi^{(5)}}_{\text{gravity}} + \underbrace{\tilde{V}_t \nabla^2 \tilde{V}_t^{(6)}}_{\text{viscosity}}$$

$\tilde{V}_t$  represents a vector quantity

The third term dominates for large scale features, while the second term dominates for small scale features. Term (3) is linear and term (2) is not. Therefore, the basic equations have not afforded us any help because the small scale features show up as nonlinear perturbations which we tend to smooth out as "noise." Not only are these perturbations difficult to model, they are impossible to observe with the present density and frequency of observing networks.

Weather modification can be considered as another part of the local forecast challenge. Hosler (1969) points out that we do not have at our disposal the means to alter the long wave positions of the westerlies or their intensity. For this reason, we are constrained to modification of small scale features embedded in the larger weather patterns. For example, a certain measure of success has been achieved in producing rain from supercooled stratiform clouds. Scientists are experimenting on the seeding of localized areas of warm clouds, particularly cumulus, in an attempt to trigger rain before it would occur naturally. Project Stormfury, a joint Navy-Environmental Science Services Administration venture, has seeded hurricanes in an attempt to modify their intensity or movement (Simpson, 1966). It is now practical to dissipate supercooled fog; and to a lesser extent, warm fog. Yet, the approach to weather modification is extremely limited because we lack a real knowledge of what is happening in the clouds. One continuing effort to resolve this deficiency is the concentrated program, Tornado Alley, near Norman, Oklahoma, using radar, aircraft, and radiosondes. As success is achieved in weather modification, the demands for such services will inevitably increase as will the demands for observations.

D. Side Effects. As we attempt to provide the observations required for both global and local forecasts, we will be faced with many side issues challenging both our technical ingenuity and our management abilities. As mentioned earlier, standardization of observational procedures is a must; as is an integrated quality control program. Definitions of terminology such as accuracy will have to be agreed upon. In point of fact, we are not even certain what bases were used to determine the accuracy figures we so easily quote. (Annex I contains an estimate of some current accuracies assembled from diverse sources.) Network calibration, not yet in being for systems such as radars and radiosonde ground equipments, is an absolute necessity. How do data from different sensors compare? McFadden and Wilkerson (1967) have the only report that I was able to find on comparisons of radiosonde and dropsonde data. Benchmark stations will have to be both upgraded in terms of parameters measured and increased in numbers (Roberts, 1969). How do we handle a periodic data? Satellites will generate incredible amounts of such data. Increasing amounts of quantitative radar data will be available in the next few years. Remote sensors, satellite observations,

miniaturized electronics, automatic data processors, and automated communications are more than solutions to our problems; they are challenges in themselves--for how shall we use these new devices effectively? These then are the challenges we face.

III. What are we doing to improve the system?  
 (...the present is big with the future...)

A. General Improvements. The network of observing stations--worldwide--is expanding, and funds are available for a continued expansion, although at a slower than desired rate. Automation of the observing function is now feasible (or nearly so) where just 10 years ago it was not--and we are automating. In the next 2 years, nations are to increase their upper air sounding programs from merchant ships from 20 to 67. In addition, more than 300 new surface stations are to be added. In fact, the WMO reports that there is about an 11% per year increase in expenditures worldwide for meteorology. Research and development programs have been initiated which range from basic investigations of surface instruments to rocketsonde and satellite probes. Remote satellite sensors are operating in the spectral region from 0.4 - 30 microns. Advancements in technology have produced operational radars and lasers. Each of these facets should be considered in a forecast of resources for the 1970's. However, I have made the arbitrary decision to concentrate in Section III on "typical" research and development programs with promise rather than on additions to the network in terms of additional stations or frequency of observations.

B. Research and Development Programs. (1) Satellite. Tepper and Ruttenberg (1969) point out that satellites reside outside the atmosphere and are capable of viewing that atmosphere in any portion of the electromagnetic spectrum. Figure 1 from their paper shows this schematically. By way of review, there are three general functions of a satellite as a vehicle for remote atmospheric sensing:

(1) Areal distribution of environmental features. This includes clouds, ice, soil moisture, snow, and meteorologically related features such as dust. The distribution may be qualitative or quantitative.

(2) Kinematic field; currently, indirectly inferred from cloud motion.

(3) Mass field including temperature, moisture, and pressure measurements.

The COSPAR WG VI report (1968) presents a comprehensive review of potential satellite applications for meteorology.

Nordberg (1968) and Colwell (1968) give a more general review of the properties of the earth and the atmosphere which can be deduced from satellites.

For the most part, satellite data have been used qualitatively, but there are exceptions. Suomi, Oliver and others have developed techniques to extract data on the wind field from cloud motions. Merritt and Smith (1968) derived quantitative information on short wave cloud patterns from satellite data. Fett (1965) developed a model for objectively classifying tropical cyclones with respect to their stage of development on satellite photographs. Hubert and Timchalk (1969) (also Meteorological Satellite Laboratory Report #33) provide regression curves relating the diameter of hurricanes as seen on satellite photographs to the maximum wind speed to be expected. A number of initial studies led up to the present system of digitizing satellite photos on the basis of discrete levels of cloud intensity and preparing mosaics. I am personally convinced that much more quantitative data is available in the photographs. For example, several investigators (Giraytys, 1962) have shown that cloud patterns could be identified and categorized using a simple spectral analysis technique. By a suitable selection of categories and the use of digitized data, cumulus cloud censuses could be taken in the tropics. Such information is vital to an understanding of the energy processes of that region.

METEOROLOGICAL INSTRUMENTATION IS BASED ON ATMOSPHERIC PROPERTIES & CHARACTERISTICS IN THE VARIOUS SPECTRAL REGIONS

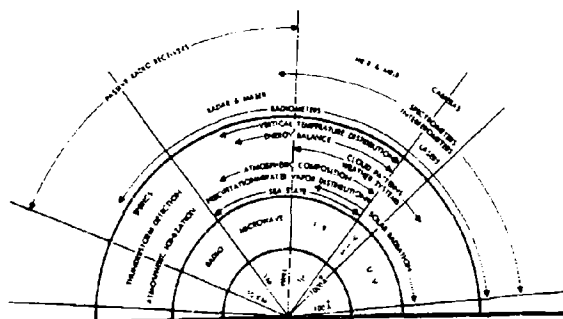

FIGURE 1

NASA SP-81-778  
12-34-69

On a quantitative basis, however, the most significant results have been from the infrared data. Merritt (1967) presents a status report on uses of the TIROS and early Nimbus infrared data, primarily for cloud cover analyses. Since atmospheric constituents radiate at different wave lengths over different altitude regions, the next step was to capitalize on this feature to obtain vertical temperature and composition profiles. This step was taken by placing a satellite infrared spectrometer (SIRS) on Nimbus III launched in April 1969. A catalogue of the Nimbus III radiometer devices is given in Table 2. Annex I contains an estimate, prepared in the Weather Bureau, of satellite data accuracies.

Table 2. Catalogue of Nimbus Radiation Detection Devices

Name	Band	Frequency
Satellite Infrared Spectrometer (SIRS)	7 channels around 15 microns (CO <sub>2</sub> ) 1 channel 11.1 microns (H <sub>2</sub> O window)	Temperature Profile Measurements
High Resolution Infrared Radiometer (HRIR)	0.7 - 1.3 microns day 3.4 - 4.2 microns night	Cloud Mapping Sea Surface Temperatures
Medium Resolution Infrared Radiometer (MRIR)	6.4 - 6.8 microns 10 - 11 microns 14.5 - 15.5 microns	Water Vapor Surface and Cloud Top Temperature Stratospheric Temperature
Infrared Interferometer Spectrometer (NASA experiment)	5 - 20 microns	Structure Profiles of Temperature, Water Vapor, Ozone, and Carbon Dioxide

Hilleary, Wark, and James (1969) describe the grating spectrometer used on Nimbus III. The method of reducing the data is described by Wark and Fleming (1966). The CO<sub>2</sub> radiation band, about 15 microns, has been split into 7 narrow spectral intervals (W. L. Smith, 1969). Each channel has a peak of radiation at a different level in the atmosphere. The 11.1 micron water vapor window provides data at the surface or top of the cloud. These eight channels provide data from which a sounding can be derived by inverting (solving) the radiation transfer equation. Figure 2 (Wark and Hilleary, 1969) gives a comparison between a SIRS sounding and one obtained from a conventional radiosonde. The major areas of disparity are, of course, at the inversions which are smoothed. Wark and Hilleary consider this to be an exceptionally important comparison as the nearly overcast cirrus clouds did not seem to affect the quality of the data.

W. L. Smith (1969) also describes the method by which one can convert SIRS data to constant pressure maps of temperature and geopotential height without the need for surface pressure data. The following procedure was used for the map shown in figure 3 (Smith, personal communication). Radiance values for several days prior to map "time" were plotted as a function of pressure for corresponding radiosonde data. Correlation coefficients were devised and used to estimate temperature and geopotential height data for the map along the lines which represent the satellite track. These temperatures and heights were used to modify the first guess field with the result shown. (The first guess field is actually the forecast prepared

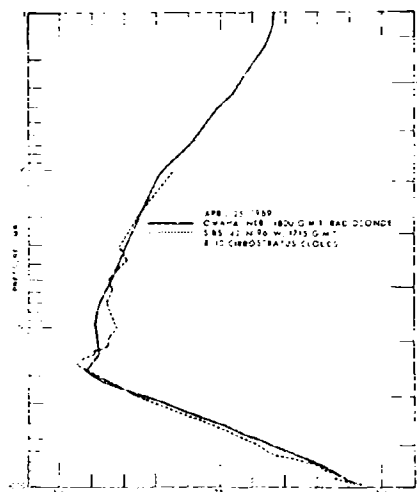

FIGURE 2. COMPARISON OF RADIOSONDE AND SATELLITE INFRARED SPECTROMETER (SIRS) DATA. WARK AND HILLEARY.

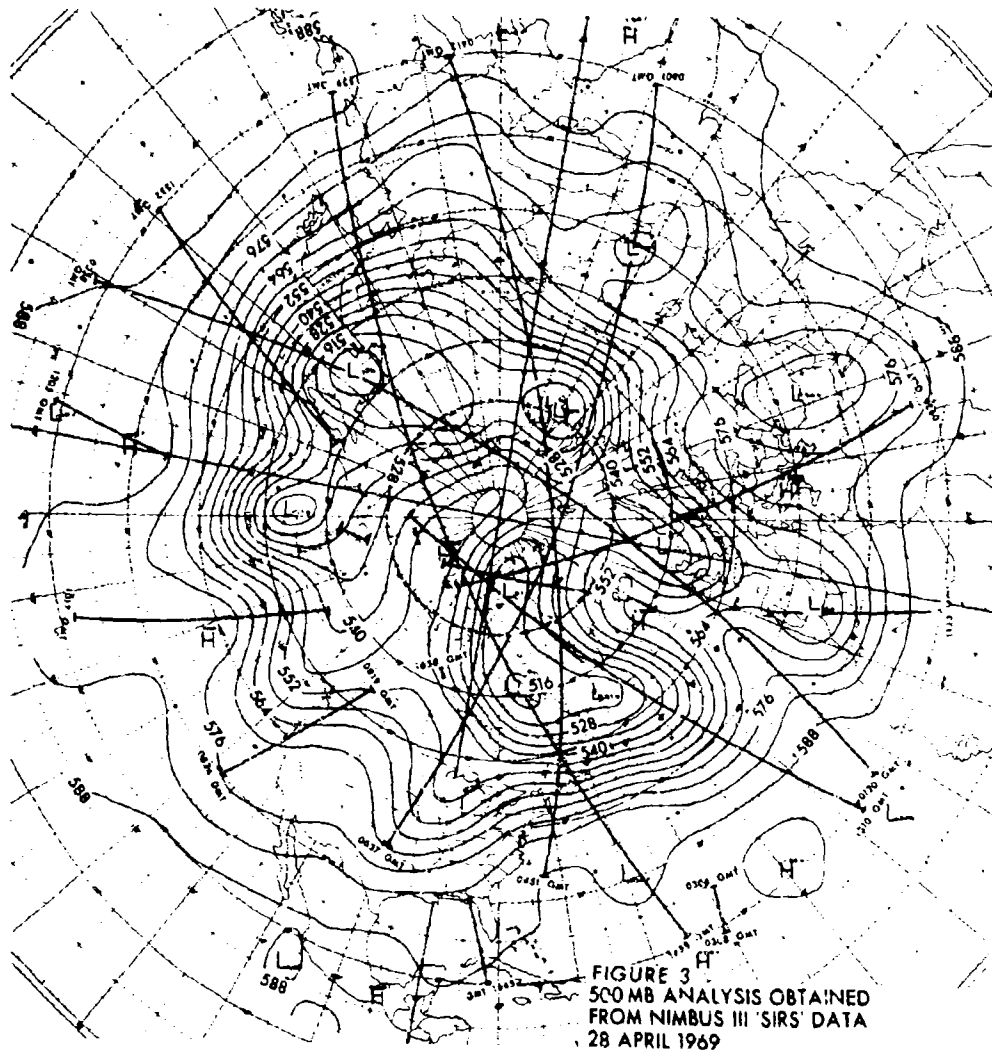

FIGURE 3  
500 MB ANALYSIS OBTAINED  
FROM NIMBUS III SIRS DATA  
28 APRIL 1969

12 hours earlier.) The National Meteorological Center has already initiated a program for incorporating this technique into the routine operational temperature and geopotential height analyses. Relative humidity profiles are to be obtained on the next Nimbus (scheduled for an early 1970 launch). Further, a scanning spectrometer will obtain data on either side of the satellite track, thus dramatically increasing the coverage.

Still open to question is the suitability of gross satellite data for aviation; the degree to which clouds will interfere with the data and, hence, the amount of bias towards cloud free areas, and the effect of smoothing over regions of frontogenesis. However, Wark and Hilleary conclude that less than 20% of the SIRS soundings do not meet meteorological standards, that the use of a single instrument negates the need for "network" calibration and reduces the random error of a map, and that cirrus clouds are not a serious detriment. There is no question but that SIRS data offer the potential for a vast improvement in the quantity and quality of data for global analyses and hence the longer range forecasts. I will return in section III C. to some serious questions raised by the success of the SIRS sensor.

The Nimbus III also carries an Infrared Interferometer Spectrometer (IRIS) operating at various spectral intervals in the band from 5 to 20 microns. Structure profiles are being obtained by NASA on an experimental basis for temperature, water vapor, carbon dioxide, and ozone. A description of the data reduction technique for water vapor is given by Conrath (1969). In a manner similar to the SIRS data, humidity profiles are obtained by the direct inversion of the radiation transfer equation and by a statistical estimation requiring correlations between radiance values and relative humidity measured by radiosondes. Conrath points out that values of relative humidity are not overly sensitive to temperature errors, but absolute values of water vapor are very sensitive to such errors. The technique is also sensitive to fluctuations in surface temperature because the "wings" of the radiation curve were included so as to obtain lower tropospheric data.

What else can be sensed remotely from a satellite? Again referring to figure 1, one finds that quantitative surface information as well as upper air data can be obtained. Sea state is specifically mentioned but one should also include sea surface temperature, soil moisture, and snow depth. Barnes (1968) mapped snow cover from Nimbus I infrared data and found that he could analyze basins as small as 10x10 miles. He obtained gross estimates of snow depth in three categories: Less than 1 inch, 1-4 inches and greater than 4 inches. Allison, and Kennedy (1967) describe an evaluation of sea surface temperature measurements using Nimbus I data (HRIR) at 8-13 microns. The agreement with aircraft radiometer and ship reports was 3-6K. Warnecke, Allison, and Forshee (1968) obtained 1-2K agreement using Nimbus II data (HRIR) at 3.4-4.2 microns. Staelin (1969) presents a discussion of how microwave emissions in the  $10^3$  to  $10^6$  micron band can be used to measure clouds, sea state, sea surface temperature, surface emissivity, and profiles of CH<sub>4</sub>, CO, H<sub>2</sub>O, SO<sub>2</sub>, O, H<sub>2</sub>O, and O<sub>3</sub>. These measurements cannot all be made with the same ease or precision, however. Microwaves also offer the potential for classifying precipitating and nonprecipitating clouds. Staelin suggests that microwave detection offers these unique advantages for remote sensing, (1) less affected by clouds than other bands for temperature measurements, (2) can distinguish between liquid water and water vapor to a good degree, and (3) sensitive to small concentrations, thus useful for data from above 50 km. Differences between ice, snow, and clouds may be identified by polarization effects. One can estimate the water content of snow from satellites. Water vapor has been alluded to, but total water vapor in a column can be obtained. The U.S.S.R. has probably done some work in this area using their COSMOS series of satellites. Density measurements are possible, but much further away in time than the period of this paper. One should not overlook albedo measurements. Arking and Levine (1967) report on attempts to determine the earth's albedo from satellite data. The 5-20 micron region incorporated on the current satellites covers some 80% of the total radiation from the earth. Some early studies of Nimbus I data showed that the calculated albedo differed from the theoretical by a factor of 1.5 (calculated being higher). We know the total solar constant to perhaps 2%, but the amount of radiation in the UV portion is only known to perhaps a factor of 2. Better definition of the variations in the UV range, of course, is fundamental to understanding the heat balance of the earth.

Despite these potential uses, satellites are not a panacea for all our observing problems. Their primary advantage lies in making gross measurements on a routine basis. Small scale features, particularly near the surface, will continue for some time to be measured more effectively by methods other than those on satellites.

(2) Remote Sensing--Ground Based. Ground based remote sensing is limited in terms of areal coverage and the number of data points over that area. However, it has the distinct advantage of allowing us to probe the lower atmosphere, particularly for small scale features. Table 3 prepared by D. T. Acheson and H. D. Parry, Equipment Development Laboratory, Weather Bureau, shows a brief summary of the current ground based, remote sensing projects underway which are aimed at obtaining vertical profiles.

(a) Radiometers. Mount, et al, (1967) gives a description of a typical radiometer sensing radiation from molecular oxygen (versus CO<sub>2</sub> for satellite borne sensors). By selecting three different frequencies 58 GHz, 55 GHz, and 54 GHz (about 5x10<sup>3</sup> microns) one obtains energy from three regions of the lower atmosphere. The largest contribution (69.8%) to the brightness temperature comes from the first 1.4 km at 55 GHz. However, at 54 GHz the same 1.4 km contributes a substantial 45%. Therefore, the data are not independent at the two frequencies and some sorting is required. This "sorting" is a major problem.

As with other remote sensing techniques, rapid changes in gradient (inversions in this case) are smoothed. The lowest or the strongest inversion is the one which is resolved the best.

Table 3. STATUS SUMMARY--REMOTE SENSING (D. T. Acheson and E. D. Parry)

1. Variable	2. Mode	3. System (Investigator)	4. Feature of Variable	5. Known or Strongly Suspected Ground Based Limitations	6. Major Ground Based Advantages	
Indirect Sensing of Vertical Profiles	Air	Active--(No Active System Having Near Term Promise of Measuring an Absolute Profile is Known)				
		Passive	IR Radiometry (NESZ)	Smoothed Absolute Profile	Little Cloud Penetration Lack of Resolution	Known Workable
	Wind	Active	Microwave Radiometry (Sperry, WPL)	Smoothed Absolute Profile	Uncertain Cloud Penetration Lack of Resolution	Known Workable Potential Cloud Penetration
			Laser X-Correlation (Mortronics)	Detailed Structure & Absolute Profile	Little Cloud Penetration Extremely Sophisticated Hardware & Data Processing	Resolution S/N Enhancement Because of Use of Active System
		Passive	Incoherent Optical X-Correlation (Drexel)	Detailed Structure & Absolute Profile	Little Cloud Penetration S/N Problems	---Simplicity
			Acoustic Radar Doppler (EDL, WPL)	Absolute Profile	Maximum Height Limited	Good Cloud Penetration Favorable S/N
	Water Vapor	Active	IR X-Correlation (NASA)	Smoothed Absolute Profile	Little Cloud Penetration Lack of Resolution	Almost Workable
			Microwave Radar (AFCL)	Detailed Structure	Questionable Absolute Profile	Resolution, Special Coverage
			IR Raman or Fluorescence (WPL)	Detailed Structure & Absolute Profile	Little Cloud Penetration Potential Haze Problems	Resolution, Potential Overcome Haze Problem
		Passive	Acoustic Radar (FDL, WPL)	Absolute Profile	Maximum Height Limited Good Cloud Penetration	Good Cloud Penetration Favorable S/N
		IR Radiometry (NESZ)	Smother Absolute Profile	Lack of Resolution		

AFCL--Air Force Cambridge Research Laboratories  
 EDL--Equipment Development Laboratory, Weather Bureau  
 NESZ--National Environmental Satellite Center, ESSA  
 S/N--Signal to Noise Ratio  
 WPL--Wave Propagation Laboratory, ESSA Research Laboratories



Results of radiometer, tower, and radiosonde comparisons are shown in figures 4 and 5. The smoothing of the inversion is quite evident in figure 4. Under the lapse conditions shown in figure 5, the agreement with tower data is excellent. Radiometers of this type yield acceptable results up to about 2 km. The device is portable and requires little in the way of calibration. Relative values are possible at anytime, but a surface temperature is required to obtain absolute temperature profiles.

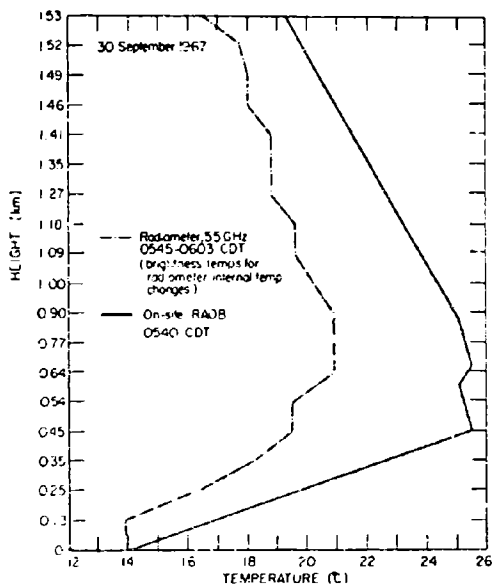

FIGURE 4 TRACING OF UNCORRECTED RADIOMETER OUTPUT RECORD AND PLOT OF RELATIVE TEMPERATURE AT DISCRETE HEIGHTS, 30 SEPTEMBER 1967.

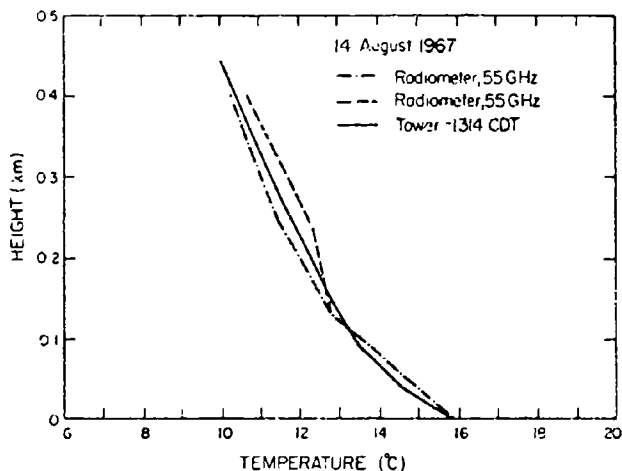

FIGURE 5 RADIOMETRIC AND TOWER OBSERVATIONS UNDER SUPERADIABATIC LAPSE CONDITIONS AT OKLAHOMA CITY, 14 AUGUST 1967.

An experimental infrared radiometer has been developed for measuring the bases of clouds. The cloud base temperature is measured, and the height is inferred from the surface temperature and a known or assumed lapse rate. A microwave radiometer is being developed for the Air Force test ranges to measure the refractive index along the ray path of a tracking radar. In practice, one relates the effective antenna temperature at 20.7 MHz, to the integrated water vapor content along the direction of the antenna.

Let me digress for a moment and discuss airborne radiometers. A number of experiments have been made using airborne radiometers operating at 8-14 microns to take measurements of ground and water temperatures. Lorenz (1967) and Fujita, Baralt, and Tsuchiya (1968) describe some of these aircraft techniques. In both cases, they obtained surface temperatures of 8-15°C higher than reported air temperature. The reason being that the radiometer "sees" the hot ground rather than the relatively cooler overlying air sensed by the conventional thermometer. (There is the identical problem with satellite radiometers.) Aircraft-borne radiometers have an application in earth resources studies and research experiments. However, except for measurements of sea surface temperature, I find little serious consideration of them for routine meteorological operations.

The Weather Bureau has developed an infrared hygrometer for measuring moisture over paths up to 2 km. The device can also be pointed at the sun to measure the integrated water vapor in a column over the instrument. The intensity of light transmitted over the path at two wavelengths near 1.73 microns is measured. One wavelength is attenuated by water vapor; the other is not and the difference in intensity is a measure of the total water vapor over the path. This technique has application to other gases as well as water vapor. To date, the IR hygrometer has not been used in routine observing programs.

(b) Visible Wavelengths (Transmissometers and Ceilometers). Remote sensing in the visual part of the spectrum is well advanced. Ceilometers and transmissometers are the two best examples. A number of attempts have been made to measure backscattered light for visibility measurements, particularly slant range visibility. Vogt (1968) describes one backscatter device and suggests that with the present state of knowledge of atmospheric

transmission, accuracies are about  $\pm 20\%$  for visibility. A microwave transmissometer for water vapor measurements is described by Beard (1969). Three frequencies (one in the infrared and two microwave, 10.4 and 23.8  $\text{cm}^{-1}$ ) are propagated over a 3.5 km path. Comparisons are made of the phase relationships and attenuation at each wavelength to determine the dry air and water vapor partial density contributions to the radio refraction. Highly sophisticated techniques are described by Fried (1969) and Ishimaru (1969) for studying turbulence and wind with optical systems. Fried would install an array of paired telescopes to record the scintillation of starlight. Computer analysis of the spatial covariances would yield data on turbulence while analysis of the temporal covariances would give information on the wind. Ishimaru suggests using a focused beam to study turbulence and wind.

A number of devices have been used experimentally for ceiling measurements, including a pulsed light (noncoherent) ceilometer. The pulsed light device has a serious timing problem for low cloud bases. This same deficiency exists for lasers.

(c) Lasers. Over 20 lasers are in use by meteorologists in the United States on at least a semiroutine basis. Optical radars (Collis, 1968) using lasers (LIDAR) have been built and operated successfully. Dust layers are particularly easy to observe and by inference inversions. Fico and Grams (1969) describe an experiment conducted in Norway to measure the height of noctilucent clouds. The Air Force Cambridge Research Laboratories have used a laser in Puerto Rico to obtain density measurements from 30 to 60 km. LIDAR's have been used to examine cirrus clouds not visible to the human eye. The LIDAR also can be trained on a cloud seen in profile to determine the cloud top.

As with the pulsed light (noncoherent) system, lasers have difficulty resolving the bases of low clouds. Large light outputs for continuous operation are difficult to obtain because the internal heat generated shortens the life of the lasing crystals. Laser observations are degraded by virga, snow, and rain as are observations from conventional ceilometers. Possible damage to the eye is a serious hazard if the laser beam should be seen by an aircraft crew or passengers. Despite these limitations, at least one firm has an off-the-shelf ceilometer which is portable and guaranteed for a year.

Lasers have also been used as backscatter sources (Brown, 1968) for visibility measurements. The results were acceptable up to about 1/2 mile. Beyond that distance, atmospheric attenuation was a limiting factor. Viezee, Uthe, and Collis (1969) conducted an experiment at Hamilton Air Force Base using lasers to obtain both ceiling and visibility measurements. The results were encouraging, but more needs to be done on interpreting laser return records and understanding the physics involved.

Little seems to have been done in applying holography to meteorology. Hall and Ageno (1968) did use a laser to investigate the dispersion of salt particles from ocean spray. A laser was mounted at right angles to a spray plume produced by waves breaking over a rock. The holographic images of the spray particles were recorded by flashing the laser onto a camera. An analysis of droplet size distribution was made by examining the resulting holograms. This general concept may be applicable to studies of particle size distribution for air pollution and weather modification. Since turbulence causes atmospheric density changes and hence changes in the refractive index, laser holography may be applicable to study the scale of turbulence directly rather than by using tracers.

(d) Acoustic Waves. In recent years, the acoustic ray tracing technique has been refined to give temperature and wind profiles. It is interesting that the first reliable report of the existence of the tropopause came as a result of scientists in France observing the sounds of cannon fire at the funeral of Queen Victoria in 1902. In this instance, sound reflection from a temperature inversion was correctly postulated. The rocket grenade technique (Nordberg and Smith, 1964) has been used successfully to probe the high atmosphere.

Little (1969) points out that few efforts have been made to develop a good theory of sound wave propagation which goes beyond the limited ray-tracing techniques. Little also points out that the acoustic refractive index (RI) is 1000 times greater than the radio RI. The slower speed of acoustic energy (compared to light) would mean that a better resolution of low cloud bases could be obtained. Theoretically, cloud height could be resolved to 10 meters which just happens to be a WMO stated requirement. Since the acoustic RI is a function of wind, temperature and relative humidity, all three parameters could be deduced. On the negative side, the energy required to produce the sound wave is large and one has interference from wind, rain, and solid precipitation.

(c) Radar. Perhaps the most successful remote sensing technique is weather radar. The two common systems are the WSR-57 (Weather Bureau) operating at 10 cm wavelength and the FPS-77 (Air Force) operating at 5.7 cm. (Here, I consider that the CPS-9 is being phased out of the inventory.) By 1971, about 40 WSR-57 radars are planned to be in operation (Bigler, 1968). Coverage is being augmented by using FAA Air Route Traffic Control radars; and joint use programs are already in operation at Salt Lake City, Utah, and Palmdale, California. The Weather Bureau has also initiated a development program for a C-Band radar to fill the gaps in the WSR-57 network.

Bigler also points out that the current network is primarily a manual one, heavily biased toward qualitative interpretation (RAREPS) of the radar scope by the operator. However, quantitative data are also available. Through the radar equation, it is possible to establish a relationship between radar reflectivity (parameterized by Z-value) and the rate of precipitation (R) in the radar echo. The next step is to derive the rate of precipitation observed on the ground. Results have varied widely, but for dense networks of raingages the relation between Z-value and precipitation rate has generally been usable.

However, Wilson (1968) points out that errors in calibration of the radar can cause apparent day-to-day differences in precipitation rate of a factor of two. He also asserts that much more needs to be done to understand the relationship between reflectivity and rainfall rate.

At least five devices have been built to digitize radar data (Z-values). Many problems exist such as the fact that one must somehow identify nonmeteorological returns so that these are not digitized. Wilk and Kessler (1969) describe a system devised at the National Severe Storms Laboratory (NSSL-ESSA) for digitizing a radar return in real time. Another real time data processing system is described by Smith and Boardman (1968) which is in use at the South Dakota School of Mines and Technology. The NSSL system is to be used this summer in a hydrologic experiment. Data analysis for this experiment is described by McCallister and Teague (1968). Data from the Oklahoma City WSR-57 will be contoured in six Z levels, sent by slow scan TV over telephone lines to NSSL at Norman, Oklahoma, digitized, and the digital data sent to the river forecast center (RFC) at Fort Worth, Texas. The RFC will prepare computer analyses of river runoff, river state, flash flood advisories, and accumulations of water in reservoirs. The Weather Bureau has also developed a device (Weather Bureau Radar Remote-WERR) (Hilton and Hoag, 1966) which remotes the scope picture via slowed down TV over telephone lines. The WERR is to be used to give meteorologists wide access to radar data in a form other than subjective radar reports.

While I have described the efforts to provide quantitative data from the WSR-57, some similar efforts are being undertaken with the FPS-77. For example, Paulson (1968) describes work being done at the Air Force Cambridge Research Laboratories to examine rainfall rate and Z level relationships.

In addition to these conventional radars, systems are available which can measure the doppler movement of particles along a radial from the radar (Lhermitte, 1968). The advantage of using doppler radars is that one can examine the dynamics of small scale meteorological phenomenon. Tornadoes, for example, are observable on doppler radar by the radial velocity of the entrapped particles, whereas by conventional radar it is just chance that the hook is seen. Three doppler radars would be required to obtain motions in X, Y, and Z and will only be possible for research purposes in the near future. However, Esterbrook (1967) and Wexler, Chmela, and Armstrong (1967) describe the successful use of doppler radars to examine the wind fields of localized storms. This is an excellent example of how we can improve our knowledge of meso-scale features using new techniques and, in turn, establish new requirements for routine observations.

High powered radars have been used to study clear air turbulence structures (Hardy and Katz, 1969). Using radars operating at 3.2, 10.7, and 71.5 cm at Wallops Island, Va., they have identified "dot" echoes as birds and insects. Echoes with horizontal extent are meteorological. Features observed have been tentatively identified as breaking gravity waves, turbulence around cumulus clouds and Benard-type cells. The feasibility of such radars for routine application has yet to be shown.

The Air Force has developed the TPQ-11 (0.86 cm) vertical pointing radar (Kantor, 1968) for detecting clouds. Kantor reports that operationally, it detects clouds only 62% of the time they occur (four operational sites), as opposed to 85% under laboratory conditions. This is an example of the difficulty one has in converting devices from R&D status to operational use.

Radars have also been used not as radars, but as data collection or retrieval systems. The Weather Bureau experimented with a device for interrogating remote raingages. The coded data were displayed on the radar scope at the location of the gage. We concluded, however, that this was an inefficient use of the radar. Some countries use their weather radar for windfinding with a radiosonde balloon-borne target. Here, again, we cannot afford to tie up our radar for  $1\frac{1}{2}$  to 2 hours tracking a balloon. Booker and Cook (1968) describe a transponder-sonde which can be deployed from an aircraft in a storm and tracked with a radar. The sonde is suspended from a superpressure balloon and records temperature and relative humidity. The sonde is interrogated by the radar which also provides position data.

(3) "Convention 1" Upper Air Observations. The radiosonde has been with us from the late 1920's. The 576-558 was introduced in 1943 and is still in use in the Caribbean. The GMD and WERT concepts were introduced about 1948. Development began in 1954 on the GMD-2 to be used with transponder for slant range measurements. The automatic data processing version of the GMD-2, the GMD-4, dates from the 1961-1963 time period. During the last 20 years, the baroswitch has been augmented by the hypsometer, the rod thermistor has been moved from inside the sonde to an outrigger, coatings were applied to the thermistor to reduce radiation effects, and several different chemical compounds have been used for the hygistor. Leviton and Hafford (1969) give a review of current upper air sounding systems.

The Air Force Cambridge Research Laboratories has made feasibility demonstrations of an advanced meteorological sounding system incorporating a ranging capability, improved radiosonde, and a digital computer. The Army has developed a combined system (AN/UMQ-7) which uses an x-band radar for ranging and 1680 MHz for obtaining the thermodynamic data. The Weather Bureau has flown feasibility flights of a modified radiosonde equipped with a Loran-C receiver. Loran-C is a navigational system which uses a master and several slave stations. At the receiver, space position can be determined by the phase relationship of the waves from each Loran-C station. Absolute position accuracy is not necessary as wind data are obtained by an incremental change in position with time. This is dependent upon how accurately one can measure phase differences. The resultant wind accuracies using the Loran-C systems appear to be better by almost an order of magnitude than the WERT or GMD accuracies. Omega (a navigational system similar to Loran-C) wind accuracies appear to be comparable to the WERT or GMD. The advantages of using navigational aids are the increased accuracy particularly at low elevation angles and the elimination of antenna angle tracking errors. The largest disadvantage is that the navigation system is not under the control of meteorologists and could be changed so as to seriously affect our operation without our approval.

The AFCL has developed a low level sounding system for use on the national test ranges. One version is balloon borne and the other is carried in a small CO<sub>2</sub> propelled rocket to about 3,000 feet. The rocket returns to earth on a parachute, and data are obtained during descent. The system is recoverable for reuse. Sampling rates on both versions are 1 per second so that detailed low level structure may be obtained.

Several research low level sounding radiosondes have been developed. Each is balloon borne with either fast commutation rates or dedicated channels for each parameter sensed. Kobayashi (1967) describes a light weight system using a glass bead for fast response and a windmill for height. Height values are reported to be accurate to  $\pm 6$  meters. Gjessing (1968) describes a device using a thin platinum wire for temperature and a piezoelectric resonator for humidity. In these last two articles, the authors emphasize the need to match sensor characteristics to the sampling rate for low level soundings.

At the other end of the altitude range, major advancements have been made in attaining altitudes up to 40 km with sounding balloons (Nelson, 1966). At present, these balloons tend to be costly and larger than that desirable for routine use. However, advances in balloon manufacture will make soundings to 40 km economically feasible before 1975. I return to a theme that I have expressed elsewhere; we have vehicles suitable for a variety of purposes; we lack suitable sensors. This is particularly true if we are to have routine balloon soundings from the surface to 40 km.

Earlier, I mentioned the need for international standardization. Hinzpeter (1969) cites 10 different sounding systems that are used worldwide for upper air measurements. World Data Center A (meteorology) lists data from 21 different radiosondes. The differences primarily are in the method of making measurements of the thermodynamic parameters. For example, temperature is measured by bead, rod, or wire thermistors and bimetal coils. The disparity

in the accuracy of systems being used by various nations has been pointed out by Finger, Harris, and Teweles (1965). They suggest that the true diurnal variation at 10 mb is about 1C, but that day-night differences for some sensors is several degrees Celsius. The distribution of these differences often follows national boundaries, highlighting the problem of analysis in areas such as Europe.

(4) Constant Level Balloons. At levels above the clouds (about 10 km), the constant level balloon has been successful. Lally (1969) reports flight durations of 15 months and more. Up to 10 km, icing on the balloon has reduced the lifetime to as short as a few days. In the period 1969-1970, the French are planning a southern hemisphere experiment termed EOLF using 500 constant level balloons. The balloons will be interrogated from a satellite for position data from which winds will be derived. The United States is planning a similar program using 30 balloons in 1970 from Ascension Island. The National Center for Atmospheric Research and NASA are planning a 1000 balloon experiment in 1973 for the tropical stratosphere. Balloons used for this latter experiment will also have a temperature sensor on board. Here, then, is a third concept (remote sensing of all sorts and radiosounding are the other two) of taking upper air observations.

(5) Aircraft Observations. Aircraft observations (APOB) predate the radiosonde. The Weather Bureau began with one APOB station in 1925 (there were also six kite stations then) and increased the program to 30 in 1937 when the first radiosonde station became operational. The last APOB station was deactivated in 1943.

One can identify three categories of use for aircraft in meteorology: (1) Research platforms for cloud physics, turbulence, and air pollution investigations, (2) weather reconnaissance, and (3) pilot reports (AIREPS). Projects Stormfury and Tornado Alley are perhaps the two better known research applications using aircraft to investigate the meteorology of severe storms. The aircraft are generally equipped with advanced instrumentation, often experimental in nature, and usually have some sort of data processor on board. Klieforth (1967) describes the types of measurements desired and their accuracy for meso- and micro-scale flight investigations. The National Center for Atmospheric Research has devised a sophisticated system for measuring temperature, humidity, drop sizes, turbulence, and obtaining radiometric data which is telemetered to a ground station for processing (Dascher, 1967). A description of the instrumentation required for cloud physics studies is given by Pettit (1967).

Perhaps the most elusive meteorological phenomenon is clear air turbulence (CAT). The literature is extensive on this subject. All results point in the same direction, CAT can be measured once found; but it is difficult to anticipate when it will occur. Hicks (1967) describes a combined aircraft-radar project to relate radar echoes to CAT occurrence. Reiter (1967) points out that aircraft can explore the energy spectrum with wavelengths between 50 meters and 100 km. He further points out that we need to know more about the eddies with dimensions less than 50 meters if we are to understand the mechanics of CAT.

The primary method of measuring CAT is with an accelerometer mounted on the aircraft. Usually the aircraft are specifically designated for research, but Hunter (1968) describes a project during which he obtained data from three commercial jet aircraft. Eastern Airlines, in a press release of July 1964, describes a company sponsored project whereby an infrared detector measures the temperature gradient ahead of the aircraft (20 or so miles). A signal is given when the gradient exceeds a given level, and the pilot is supposed to maneuver to avoid the area of inferred CAT. I have not found any published results of the Eastern test. An AFCRL study to sense temperature gradients as an indication of CAT (McLean, 1965) proved inconclusive. Axford (1968) describes a method of using an inertial guidance system to measure directly gust velocity. While many of the sensors used in turbulence and cloud physics experiments are "standard" and available "off-the-shelf," there are no routine programs in operation to systematically observe parameters related to either area.

I should mention at this point that aircraft have been used to make routine observations for air pollution purposes. Fixed wing aircraft have limited use, but helicopters have proved to be useful. Temperature and relative humidity probes have been flown successfully and several routine sounding programs are in operation.

The second use for aircraft is for weather reconnaissance. Both the Navy and the Air Force fly preplanned missions for this purpose. Participants at this conference are well aware of the details of this program. The Air Weather Service has asked for improvements to their

system, primarily in terms of obtaining thermodynamic data above flight level (by rocket-sonde) and wind data below (Kahle, 1967). The general feasibility of obtaining rocketsonde data above the aircraft and wind data below has been demonstrated. However, the successful operational employment of either concept has yet to be made.

Voluntary aircraft reports (AIREPS) are, of course, familiar to each of us. The Weather Bureau has recently been successful in almost doubling the number of usable AIREPS at the National Meteorological Center by eliminating communication bottlenecks. The major problem, however, remains that some routes are overcovered while whole areas of continents are not covered at all. Better communications can only provide minimal improvement. Fletcher (1969) describes in concept a system for automatically collecting data from aircraft via satellite. Several suggestions have been made over the years to place automatic sensors on board aircraft; but for various reasons, little has been done. However, the advent of jumbo jets and supersonic aircraft substantially increases the commitment of an airline. Hopefully, one will find a more receptive attitude to automatic meteorological sensors on board commercial aircraft.

(6) Surface Instrumentation. Surface instrumentation is usually neglected in R&D programs except where it directly affects aircraft operations. There seem to be two reasons for this. First, many of the sensors such as barometers, thermometers, wind vanes, etc., are considered to be "adequate" for our general needs. I should add that several are not: For example, the measurement of precipitation type, amount, and intensity. Second, radar, satellite, and upper air development programs usually have higher priority than programs for surface instrumentation. I will only cover two aspects of surface instrumentation development in this section: Portable stations and marine. The foremost problem of surface instrumentation is automation, which I will discuss in the next section.

Several portable (usually hand held) stations have been developed for use by the military. One such system was devised for the Air Force by AFCRL. There are two segments: A surface station and a PIBAL station. Each segment weighs 5 lbs. and is self-contained for use by one person. The surface segment can be used to measure wind speed and direction, temperature, pressure, humidity, amount of precipitation, and cloud base (clinometer). The PIBAL segment contains charged cylinders for 10 gm balloons, theodolite and all necessary tables. B. Weiss of the AFCRL has fabricated several sets of these equipments to be evaluated in air pollution programs.

I will touch only briefly on marine and oceanographic measurements. Marine meteorological observations consist of raob soundings using a 403 MHz system on some 20 merchant ships and relatively crude surface observations on some 2000 other vessels. Surface pressure, temperature (air and water), and relative humidity are measured by instruments. All other surface observations (winds, waves, weather, etc.) are estimated. I know of no United States efforts to improve the calibre of the routine, surface marine observation. Significant advancements are being made for research purposes, however. The Weather Bureau has completed development of a stabilized antenna for upper air windfinding at sea. The use of navigational aids for windfinding (Loran-C/Omega) is also applicable.

A Meteorological Oceanographic Surface Data Acquisition System was developed by the Research Triangle Institute for use during BOMEX (Shinners, 1969) to include a dew cell, thermistor, infrared radiometer, wind anemometer and vane, solar pyranometer, and a bead thermistor for surface temperature. Additional data are recorded on vessel movement, atmospheric pressure, time and the visually determined elements of clouds, weather, visibility, and sea state. These and similar systems are much too sophisticated and costly for routine network operations. (Observations from buoys will be covered under the section on automation.)

This hurried treatment does not adequately cover the continuing work being done on radiation integrators, viscous damped wind vanes, hygrothermometers, instruments to be used as standards for humidity and pressure measurements, improved rain gages (there are some eight different types which should be calibrated and perhaps standardized), and snow depth indicators. I think it is safe to say, however, that the work being done is of long standing duration and is at a relatively low level of effort. The results will improve existing techniques and programs, but will not seriously alter the future data acquisition system.

G. Automation of the Surface Observation. Our primary goal in automation has been to devise a system which will take a complete surface observation "untouched by human hands." There are two basic reasons why the goal has not been reached: (1) We have tried to adapt for use with machines, sensors which were originally designed for humans, and (2) we have

tried to devise a machine which would obtain observations according to criteria based on human capabilities and limitations. A major reference for understanding the role and status of automatic stations is WMO Technical Note #82, 1966. It contains the Proceedings of an International Symposium on Automatic Stations.

One may define three categories of automatic stations.

Type I--Data Logger. Records information from sensors. No display of data (except on the record which may be magnetic tape) and no communication capability. Fixed data rate. Usually d.c. operated.

Type II--Intermediate. Accepts data from sensors. Does simple processing such as wind averaging. Capability for manual input of data. Optional capability for local output via displays or printed record. Communication usually by radio or longline. Fixed data rate. May vary rate by simple adjustments to the station. Usually a.c. operated.

Type III--Advanced. Accepts data from sensors or manual input. Displays information locally. Advanced level of data processing for various statistics and climatological records. Can be programmed for a flexible data rate. May program itself to take specials when conditions warrant. Communication is via radio or longline.

(a) Type I--Data Logger. Data loggers have their primary application in agricultural, hydrologic, forestry, climatological, and related programs. Their purpose is primarily to monitor the elements at specified intervals and to provide a record. As with each of the other types of stations, the proper design of the sensors is more of a problem than the construction of the recording apparatus. Fritschen (1969) discusses specific problems of instrument design such as converting from analog voltages to digital, sampling procedures, and scaling the signals into physical units. Rider (1969) provides a resume of the data loggers which are in use. Single parameter recorders are available for operation from batteries for periods up to 12 months. Records are made primarily on strip charts, usually pressure sensitive to avoid problems with ink. Recently, magnetic tape cartridges have been adapted for use with simple data loggers. This procedure provides for automatic data reduction at some central location. Sumner (1965 and 1966) provides a description of long period data loggers for wind (speed and direction) and duration of sunshine.

Simple data loggers are available for up to nine elements, all recorded on magnetic tape (Strangeways and McCulloch, 1965). Most uses, however, require that only 3-5 parameters be measured. Besides the meteorological parameters, various sensors are available for radiation measurements, soil temperature and moisture, leaf wetness, and air pollutants including both chemical and particulate matter.

Developments underway are aimed primarily at providing climatological data on 5-7 parameters for unattended periods up to 30 days at a cost of under \$500 per unit. We are a long way from reaching this goal.

(b) Type II--Intermediate. The distinguishing features of this type station is that real time communication is possible (as opposed to no communication for the Type I) and data processing is limited to simple tasks such as a time average for wind speed (Type III has the capability for more sophisticated data processing). The Weather Bureau has developed a Type II station named the AMOS III-70 (Hexter and Waters, 1968). The parameters measured are pressure (altimeter), temperature, relative humidity, 1 minute averaged wind speed and direction (viscous damped vane), and precipitation accumulation (tipping bucket). Given suitable sensors, the capability exists to add-on precipitation occurrence and type, visibility, and cloud information. The station is a.c. powered and communicates via standard FAA teletypewriter circuits. An optional module is available for the manual input of ceiling, visibility, obstructions to vision and remarks. Manual input data may be inserted at either of two locations enabling one to transfer responsibility to the tower under certain circumstances. A module is to be developed for a local, visual display of the data.

Several commercially available devices fitting the general description of Type II stations are described by Hexter and Spivey (1969). The communication and data processing portions of these systems are well advanced, but the sensors are generally inadequate. One system, designed by Packard Bell, is in use at 10 locations in New York City for air pollution purposes. Another system produced by Hy-Tel (Thiokol Chemical Company) is being used by the Weather Bureau to relay data from precipitation storage gages near Sacramento, California. A

A third station has been developed by Motorola. Various combinations of this latter system are in use by the Atomic Energy Commission, Corps of Engineers, and Bureau of Land Reclamation. Each of these three transmit data via VHF radio. Communication may also be by land-line. Interrogation can be automatic or on demand. The data can be automatically processed at the base station or manually reduced depending on the amount of money one wants to invest. Power sources are usually d.c. Several models are available which have propane generators to charge the battery. An expendable station part way between Types I and II (Hardin, 1966) has been constructed at AFCRL. It operates on a battery for about 2 weeks telemetering information via VHF radio (range is about 50 miles). The station is mounted on a "spear" which implants itself in the ground after being dropped from an aircraft.

Table 4 indicates the wide range of capabilities which could be built into a Type II automatic station. The AMOS III-70 is taken as the "typical" Type II station. Percentage values in the body of the table refer to that part of the total number which should have the associated capability.

Table 4: Potential Capabilities of Type II Automatic Weather Stations

Observational Elements or Modules	Uses						
	FAA Back- up (part time)	Coast Guard	Aviation (full or part time)	Public	Marine	Hydrolog- ic	Fire Weather
Total No. Required (WB)	113 (est.)	100 (est.)	200 (est.)	300 (est.)	200 (est.)	200 (est.)	350 (est.)
Processor	X	X	X	X	X	X	X
Pressure (Alt. Set.)	X	X	X	10%	X		
Pressure Tend.	30%	30%	30%	10%	30%		
Temp.	X	X	X	X	X	X	X
Max.-Min. Temp.			10%	10%	10%	10%	
Dewpoint	X	X	X	X	X	X	X
Wind Direction	X	X	X	X	X		X
Wind Speed	X	X	X	X	X		X
Wind Gusts	X	X	X	X	X		
Precip. Amount	X	X	X	X	X	X	
Precip. Yes-No	X	X	X	X	X		
Precip. Type			X	X		X	
Snow (Water Equiv.)						X	
Snow Depth						X	
Manual Input & Remarks	X		X				
Visibility	X		X	10%	20%		
Cloud Ht.	X		X				
Conc. of Pollutants				60%			
Fuel Moisture							X
Water Temp.		X			X	X	
Wave Ht.		X			X		
Tide Level or River Stage		X			X	X	
Environmental Protection		X			X		
Difficult Installation		10%			10%		
Remote Package (RAMOS)		10%	10%	75%	10%	75%	100%
Radio or Telephone		10%	5%	10%	10%	75%	75%
Visual Display	X		90%				
Recording of Data	X	X	X	X	X	X	X



A variation of the Type II station is described by Aronsson (1969). This system has a central programmer which automatically "dials" the telephone number of each station and receives the message as a series of tones. The tones are processed into a meteorological data message and are used either at the central site or transmitted over the weather teletypewriter network. This system is being installed in Sweden to cover the entire country. The elements measured are pressure (aneroid stack of 12 capsules), temperature (platinum resistance thermometer), humidity (hair hygrometer), wind speed (cup anemometer), wind direction (mechanically damped vane), precipitation (tipping bucket), visibility (backscatter meter), and cloud amount (scanning infrared radiometer). Several similar systems are in use around the United States which interrogate sensors via telephone. Tide, river, and rain gages, and wind sensors have all been connected to such systems. The Weather Bureau has a system called Automatic Hydrologic Observing System (AHOS) which is used primarily for river and rain gages.

(c) Type III--Advanced. The advanced automatic weather station concept is to duplicate completely the surface synoptic observation. The main difficulty is the provision of information on subjective parameters: Ceiling which represents both cloud cover and cloud height, prevailing visibility, and obstructions to vision. The AN/FMQ-5 was developed for the Air Force to meet this goal and the AMOS-V was developed by the Weather Bureau for the same purpose. In both versions, extensive field trials showed the inability of the sensors to provide the information required.

(d) Marine Automatic Stations. The two best known meteorological buoys in the United States are the NOMAD (U.S. Navy) and MAMOS (Weather Bureau). (I will not consider predominantly oceanographic buoys such as those being developed by the Coast and Geodetic Survey.) NOMAD is in operation in the Gulf of Mexico reporting each 6 hours. Signals are sent by Morse code to a shore station where they are processed into meteorological data and placed on the teletypewriter network. MAMOS was similar to NOMAD in its sensors and basic concept, but the data were to be sent in the international meteorological format over radio teletypewriter for automatic entry on the national system. A number of design and construction problems arose with MAMOS. This coupled with the recent decision to incorporate national buoy activities under the Coast Guard resulted in the Weather Bureau decision to terminate the MAMOS program.

Various development activities are being conducted in the Coast and Geodetic Survey, Navy, and National Environmental Satellite Center to develop specialized buoys from which meteorological data will be obtained. The so-called "Monster Buoy" is being used to replace Coast Guard light ships, and we will receive meteorological data from these providing suitable sensors can be obtained. Because of their cost and maintenance requirements, few monster buoys will be used in the near future. The recent success of the 7-foot discus buoy built for the National Environmental Satellite Center offers a potential for large numbers of relatively cheap platforms which can be interrogated by satellites, providing suitable sensors are designed.

The heart of the United States buoy program is the National Data Buoy System to be designed, built, and tested by the Coast Guard. The current status is that a systems study has been completed. The study report (Systems Development Corporation, 1969) contains a compilation of data requirements, various system configurations are evaluated, and the direction to be taken for equipment development is recommended. Equipment requirements are being prepared by the Coast Guard. A prototype system of some 30-50 buoys is to be tested in the 1973-75 time period. A full program of several hundred buoys is planned for the late 1970's. Fund requests have been drastically cut, and it is likely that these 3 goals will not be met.

A number of questions have yet to be resolved, such as how does one obtain upper air data which are more important than surface observations over the oceans? The Navy has experimented with launching small rockets from floating platforms to simulate buoys and this may be the answer.

C. Summary--What are we doing to improve the system? Worldwide data acquisition programs are expanding in terms of total observations taken and the quality of the data. Serious equipment deficiencies exist, and development programs have been initiated. The deficiencies stem from many sources, but might be generalized by the statement that we continually require the sensors to provide information beyond their design capability. Throughout the system, a major problem is one of sensors not being adequate for changing requirements. Further, recent technological advances in data processing and electronics have caused us to take a

critical look at systems which were designed some 20 or more years ago. Too often "new" systems have really been new data processors or new communication devices tied to "old" sensors. But, this fact has been recognized, and one can find increased emphasis on sensor design. However, we have a long way to go.

As for development of upper air systems, the successful demonstration of satellite remote temperature profiles has created a situation which brings to the fore the question of the relative roles of remote versus in-situ measurements. Indirect soundings from the ground are also being pursued, and the combination of surface based and satellite based sensors seems to be a logical one to pursue for the 1970's. The increased emphasis on aperiodic data certainly raises basic questions on the requirements for synoptic data. In fact, the need to restate our requirements for data is critical if we are to properly evaluate all the promising systems which are available to us. Surface automation nearly still born in the 1950's is undergoing a new resurgence of life. Once again, however, we need to define very precisely what each automatic station is to do in terms of real data output, and we must design our sensors to match the capabilities of a machine not a man.

During the next few years, it is not difficult to forecast that a new low level sounding system will be developed based on either an acoustic or microwave radiometric technique, the use of navigational aids for rawinsending will be completed, radar data will be enhanced by digitization, automatic stations suitable for all uses except the duplication of a synoptic or aviation observation will be available and buoys for networks (as opposed to research use) will be in the water under test. The real unknown is how much money will be available to purchase any of these devices for routine use? I have no inside answer to that question. Therefore, the forecast in the next section will be made through a crystal ball clouded by financial uncertainties.

Before I make the forecast, however, let me philosophize on a serious management problem. In my considered opinion, the most crucial issue that we must resolve is the one of relative priorities. I hope it is obvious to the reader that there has been proposed a multiplicity of sensors, concepts, systems ideas, gadgets or what-have-you for nearly every meteorological observing problem that we have. A fundamental question is where do we put our limited resources, both R&D and operational? We must first answer the question, what are the true data requirements? Virtually all present meteorological requirements are stated in terms of equipment or are based on the assumption that certain equipment is available. We need answers to such questions as what are the relative roles of satellite and radiosondes, of radar and satellites, of satellites and surface stations, and of radar and surface stations? Having satellite sounding data, can we terminate routine radiosonde observations at 300 mb and soundings to 10 or 5 mb with precision instruments at only a few locations? If so, what does this imply for our ongoing upper air development programs? Can satellites provide enough cloud information to supplant surface observations of cloud type and amount? Are buoys required or can satellites and ships of opportunity provide sufficient data over the oceans? Can radars provide all the information required on precipitation type or amount, or both? Some of these questions are of long standing duration. Others have been studied and partially answered, often from parochial viewpoints. But nowhere can I find a basic statement of minimum as well as maximum data needs, irrespective of how the data are to be obtained. Each analysis of data requirements begins with or depends upon a study of available data acquisition systems. I suggest that the first task for the 1970's is a reevaluation of data needs and priorities. This is a task, I fear, which may not be done.

#### IV. What Systems Will be Operational in the 1970's (...the future might be read in the past...)

A. General. To this point I have covered the major challenges to be faced in the field of data acquisition. Briefly restated these are:

- (1) Global, long range forecasts
- (2) Mesoscale, short range forecasts
- (3) Side effects
  - (a) capitalize on technology
  - (b) standardization
  - (c) calibration
  - (d) determination of accuracy
  - (e) use of aperiodic data

I have also discussed some of the R&D programs directed toward meeting these challenges. Emphasis is being placed on:

- (1) Remote sensing
- (2) Upper air soundings
- (3) Radar, particularly obtaining quantitative data
- (4) Automation of the surface observation

A number of deficiencies have been noted in both our current system, and the direction that our R&D efforts are taking. Unresolved problems center around:

- (1) Sensor development, particularly for upper air soundings and surface automatic stations
- (2) The relative roles of remote and in situ observations
- (3) A reevaluation of data requirements

In preparing a forecast, it is always tempting to follow the established trend. Since meteorology became organized in the late 19th century, the trend has been to add slowly to existing facilities. I mentioned in the introduction that one of the pillars of this forecast is that we have a system which is in existence and which will be added to in a conservative manner. While this certainly is true, I think it would be dangerous to forecast according to the past trend. In my opinion, the twin developments of remote sensing and automation represent major inflection points sending the trend upward. The major changes made in our system in the 1970's will be as a result of these two developments.

**B. Estimates of System Capability.** As mentioned earlier, Annex I contains estimates of current and anticipated observational accuracies. Tepper (1969) prepared the data in tables 5 and 6 which supplement Annex I. In table 5, he suggests one way in which balloon and satellite systems might be combined to provide the data required by GARP. Tepper gives an analysis of the capability of such a system to meet global forecast requirements in table 6.

There is little to be said about Annex I and tables 5 and 6 as they are estimates based on the best information available at present and suffer from all the shortcomings of that information. I used the data contained in these tables extensively to sort out and classify, filter, if you will, the possible combinations of new systems which might exist in the 1970's. The result of that filtering process is contained in the next section, The Forecast.

**C. The Forecast.** The data acquisition system of the late 1970's will rely heavily on satellite data to satisfy the general needs of the National Meteorological Center. A system of these satellites will be in orbit taking vertical sounding data as well as cloud information. The rawinsonde network will have substantially the same number of stations, but the purpose will be primarily to provide reference data. Therefore, the frequency of observation will be one sounding per day. This frequency will be augmented, on request, to provide detailed lower level (to 300 mb) data to augment satellite data. While the overall frequency of observation will be reduced, upwards of 15 stations in the United States will conduct that sounding to about 2 mb (40 km) with precision radiosondes. Mobile rawin stations (using Omega for wind determination) will be in use to provide a dense network in the Midwest during the tornado "season" and along the coasts during the hurricane "season." Remote low level sounding systems will be in operation in at least 30 cities for air pollution advisories and forecasts. Throughout, the rawinsonde program (including low level profiles) will be automated to the point that only one observer will be required. AIREPS will be collected automatically from aircraft. The AIREP will include information on position, height (or pressure altitude), temperature, wind, and turbulence. I believe that horizontal sounding balloons will be used primarily for research projects since they are most effective above the cloud levels and would be poor competition for satellites.

The system just described would be further augmented by a few buoys placed in strategic locations so as to provide upper air data below cloud levels over the oceans. The OSV's (for upper air data) and the merchant ship radiosonde program will be phased out toward the end of the decade.

The radar program will be greatly augmented by the introduction on a limited basis of computer composited charts isoplethed for 2-levels. Digital radar data will be distributed nationally over telephone lines. Further, a few (5-10) doppler radars will be in existence for tornado detection and analysis of other local, severe storms. A C-band radar system of

Table 5. SUMMARY OF PROPOSED SPACE-BASED SYSTEM FOR EARLY GARP EXPERIMENT

Data	Satellites			Balloons*
	Geostationary	Sun-synchronous Low-altitude	Equatorial or Low-inclination	
1. Wind	Visible and IR scanners for high resolution cloud observation at frequent intervals	FOLE-type and/or differential doppler balloon location system	EOLE-type and/or differential doppler balloon location system	600 at 200-150 mb, tropics, mid-latitudes; 300 at 850 mb tropics; 100 special
2. Temperature	(possibly IR sources for temperature profiles	Multichannel IR and microwave spectroradiometer for temperature profiles	---	Thermistor
3. Reference Pressure	---	---	---	Pressure height (at 200-150 mb)
4. Water Vapor	---	Microwave sounder for total water vapor; possibly additional IR channels for water vapor profiles	---	Questionable
5. Cloud Cover and Cloud Height	High resolution, two channel IR/visible radiometer	High resolution, two channel IR/visible radiometer	---	---
6. Data Collection	VHF or UHF transponder	VHF or UHF transponder	---	---

\*Constant level balloons

Table 6. ANALYSIS OF DATA SUPPLIED BY PROPOSED SPACE-BASED SYSTEM

	Domain	Resolution	Accuracy
1. Winds from Balloons*	Low-level tropics (possibly also subtropics)	≈ 400-500 km	Satisfactory
	High-level tropics	May be poorer than 400 km unless balloons replenished during experiment	Satisfactory
	Low-level extra tropics	None proposed	
	High-level midlatitudes	≈ 400 km	Satisfactory
	High-level high altitudes	May be satisfactory in summer polar hemisphere if suitable launch location used; winter polar cap probably not possible	Satisfactory
from Cloud Displacement	Tropics and midlatitudes wherever suitable clouds exist	Not known yet	≈ 2 m/sec

(continued)

	Domain	Resolution	Accuracy
2. Temperature Balloon	Low-level tropics	400-500 km	0.5C
	High-level tropics and midlatitudes	May be marginal in tropics but good in midlatitudes	0.5C
Vertical Soundings	High-level high altitudes	May be satisfactory in summer polar hemisphere if suitable launch location used; winter polar cap probably not possible	
	Microwave may give essentially global soundings to surface or to level or rain clouds; IR soundings give quasi-global to surface or cloud level	Acceptable in horizontal; only 3-4 degrees of freedom in vertical in troposphere	±2.0C
3. Reference Pressure Balloons	Tropics, midlatitudes (over oceans only)	Adequate	±10 m with radio altimeter
4. Water Vapor	Global	Horizontal resolution good. No vertical resolution (total content) and over oceans only with microwave; two layers above clouds and in absence of cirrus with IR	---

\*Constant level balloons

some 20 stations will fill in the WSR-57 network east of the Rocky Mountains. However, a major unresolved problem will be the calibration of the radar network, and this will retard the use of nationally digitized and processed data.

Complete surface reports for nonaviation purposes will be in the process of being automated on a systematic basis by the middle 1970's. Automation for specific programs such as hydrology will be well advanced. The data requirements of aviation in the terminal area will have been revised so as to permit complete automation, but the R&D program will not have been completed by the end of the decade. Highly versatile, "expendable" automatic stations will be available and in use for seasonal programs such as fire weather forecasts, agriculture, or marine forecasts. Dense, but localized, networks of stations reporting via radio or telephone will be in existence around the 30-50 most populous cities. This latter will also benefit aviation terminal forecasts.

The surface observing program will make use of the laser or another high intensity light source for aviation observations. The parameter may be called slant visual range or some other term, but the parameter measured will be the distance the pilot can see along his landing path. In addition, development will be progressing to adapt the laser to low level wind shear measurements near airports.

On the international scale, small buoys will be in limited use for surface and subsurface data. In particular, the coastal areas of the United States will be covered with upwards of 100 small buoys. Questions of relative cost versus data value will still be unresolved for a worldwide network of buoys. Therefore, I foresee a limited number (less than 25) of large buoys capable of taking both upper air, surface, and subsurface observations. Merchant ships, of course, will be better equipped; but the instrumentation for surface observations will lag far behind land stations. There will be a significant increase of subsurface data from merchant ships using the expendable bathythermograph.

C. Conclusion. The final conclusion is that the 1970's will be a time of innovation and serious questioning of how and why we take observations. It will also be a time of initial implementation of networks of "new" devices oriented specifically toward the mesoscale forecast problem. For this we can thank remote sensing from both satellites and the surface.

Remote sensing and automation will be the two areas of major change. Both will provide for greater coverage, but the demands on communications will be severe. Finally, the major unknown in my "forecast equation" is the support we will receive from Congress. This is a problem of salesmanship on the part of all of us.

#### Annex I

##### Current or Anticipated Accuracies of Upper Air Observations

###### A. Geostationary Satellites (current).

RMS error for vector wind of 10 knots for clouds at any altitude. Speed will be measured directly from cloud position on consecutive photographs from geostationary satellites. Cloud altitude will be determined from infrared measurements of cloud temperature.

###### B. ITOS Satellite (1975) and Nimbus III (current except for item 5):

##### Observational Accuracies of Meteorological Parameters for Nimbus Series

###### 1. Temperature Soundings

1-2°K from 10 mb level to top of cloud layer  
2-3°K below top cloud layer  
Inversions (except tropopause) will tend to be smoothed out

###### 2. Height of pressure surfaces

Within 20 meters with clear sky  
Within 40 meters with overcast sky

###### 3. Thickness of layers very accurate above clouds

###### 4. Horizontal thickness gradients very accurate above clouds

###### 5. Relative Humidity within 15% of actual values

##### Additional Information for ITOS

###### 1. Satellite measures temperature as a function of pressure

###### 2. Location accuracy of sounding; 20 miles, except 10 miles with reference points

###### 3. Air column measured is 15-120 miles in diameter at surface

###### 4. Orbit time about 2 hours

###### 5. Equator crossings advance 1800 miles per orbit

###### 6. Soundings taken every 12 seconds (30 orbit miles) at following points:

- (a) 2100 miles to right of track (35° slant angle)
- (b) 1050 miles to right
- (c) vertical
- (d) 1050 miles to left
- (e) 2100 miles to left

Soundings of successive passes will overlap. Miles refer to lateral displacement of sounding from orbit measured at the earth's surface.

###### 7. To be operational in 1975

###### 8. Data will be available once per day within 20 minutes after last pass from which data are used (subject to change if priorities change).

C. Unmanned Ocean Buoys (1975-1980).

1. Not expected to be operational on a global basis
2. Temperature and pressure accuracies will be very similar to current radiosonde accuracies
3. Will not measure winds

D. Constant Pressure Balloons (1975).

1. Temperature RMS Error 0.2%, less than 1C
2. Humidity will probably not be measured
3. Balloon will depart from intended density surface by an averaged 0.15%
4. Pressure calculations will have an RMS error of 0.25%. No pressure height data will be determined
5. Balloon location RMSE one mile when measured by orbital satellite and five miles by geostationary satellite
6. Wind measurements accurate to 2 knots vector from orbital satellites and 7 knots from geostationary satellite. This assumes fixes every 80 minutes from orbital satellite and every 60 minutes from geostationary
7. 600 mile grid planned for portion of globe south of 25°N. This will require 1,600 balloons. Will use 2,400 balloons due to clustering
8. Test scheduled for 1970 in tropics with 100 balloons

E. Rawinsonde (current).

1. Pressure
  - (a) Aneroid (range 1050 to 5 mb): accuracy  $\pm 2$  mb; resolution about 0.5 mb
  - (b) Hypsometer (range 50 mb and lower): accuracy  $\pm 1$  mb (50 mb) becoming 0.3 mb (10 mb and lower); resolution about 0.1 mb
2. Temperature: accuracy  $\pm 1$ C; resolution about 0.3C
3. Relative humidity (carbon hygistor):  $\pm 5\%$  in the range of relative humidity between 10 and 90%, and for temperatures above 0C  $\pm 10\%$  for temperatures ranging from -20C to 0C; resolution about 1%. Accuracy is unknown below -20C
4. Wind (using Loran-C this could be improved to 2-5° on direction and 1-2 kts. for speed)
  - (a) Direction: accuracy  $\pm 5^\circ$ ; resolution about 1°
  - (b) Speed: accuracy  $\pm 5$  kts. using transponder, generally  $\pm 10$  to 20 kts. without transponder--depending on distance of balloon from station resolution about 1 kt.
  - (c) Velocity: 5 kts. using transponder, 2 to 30 kts. without transponder velocity error increases as the square of the distance of the balloon from the station.

F. Aircraft (current and 1975).

1. Temperature: 1 to 2C
2. Wind: 5° and 5 kts. over land and 10° and 10 to 15 kts. over water if doppler equipped. More than 90% of AIREP winds are doppler

"REFERENCES"

- Allison, L. J., and J. S. Kennedy, 1967: Evaluation of sea surface temperature as measured by Nimbus I high resolution infrared radiometer. NASA Technical Note D-4078, Nov.
- Arking, A., and J. S. Levine, 1967: Earth albedo measurements July 1963 to June 1964. Journal of the Atmospheric Sciences, 24 (6): pp. 721-724.
- Aronsson, M., 1969: Automatic weather data acquisition via public telephone networks. Paper presented at the AMS Symposium on Meteorological Observations and Instrumentation, Feb.
- Ashford, O. M., 1969: Status of World Weather Watch Plan. Paper presented at the Symposium on Meteorological Observations and Instrumentation, Feb.
- Axford, D. N., 1968: On the accuracy of wind measurements using an inertial platform in an aircraft, and an example of a measurement of the vertical structure of the atmosphere. Journal of Applied Meteorology, 7 (4): pp. 645-656.
- Barnes, J. C., and C. J. Bowley, 1968: Snow cover distribution as mapped from satellite photography. Water Resources Research, 4 (2): pp. 257-272.
- Baum, W. A., 1969: Implications of advancing technology on needs for world meteorological information. Paper presented at the AMS Symposium on Meteorological Observations and Instrumentation, Feb.
- Beard, C. I., W. T. Kreiss, and W. G. Tank, 1969: A multiwavelength line-of-sight experiment for remote atmospheric sensing. Proceedings, Institute of Electrical and Electronics Engineering, 57 (4): pp. 446-458.
- Bigler, S. A., 1968: Programs and plans for weather radar in the U.S. Weather Bureau. Proceedings, 13th Conference on Radar Meteorology, pp. 552-554, Aug.
- Booker, D. R., and R. A. Cook, 1968: A temperature-humidity modulated radar transponder for storm studies. Proceedings, 13th Conference on Radar Meteorology, pp. 352-355, Aug.
- Brown, R. T., Jr., 1968: Final results of lidar experiments for determination of atmospheric transmittance over horizontal and slant paths in fog. Proceedings, 13th Conference on Radar Meteorology, pp. 524-529, Aug.
- Conrath, B. J., 1969: On the estimation of relative humidity profiles from medium resolution infrared spectra obtained from a satellite. Journal of Geophysical Research, 74 (13): pp. 3347-3361.
- Cospar Working Group IV, 1967: Status report on the application of space technology to the World Weather Watch, June.
- Collis, R. T. H., 1968: Lidar observations of cirrus clouds. Proceedings, 13 Conference on Radar Meteorology, pp. 530-534, Aug.
- Colwell, R. N., 1968: Remote sensing of natural resources. Scientific American, 218 (1): pp. 54-69.
- Dascher, A. J., 1967: Hybrid airborne data acquisition system. National Center for Atmospheric Research, Technical Note No. 29: pp. 163-179, July.
- Davies, D. A., 1969: Future role of the World Meteorological Organization in international observing programs. Paper presented at the AMS Symposium on Meteorological Observations and Instrumentation, Feb.
- Esterbrook, C. C., 1967: Some doppler radar measurements of circulation patterns in convective storms. Journal of Applied Meteorology, 6 (5): pp. 882-888.
- Fett, R. W., 1965: Tropical cyclone intensity interpretation from pictures. Proceedings, Interregional Seminar on the Interpretation and use of Meteorological Satellite Data, Tokyo, Oct.
- Fiocco, G., and G. Grams, 1969: Optical radar observations of mesospheric aerosols in Norway during the summer 1966. Journal of Geophysical Research, 74 (10): pp. 2453-2458.
- Finger, F. G., M. E. Harris, and S. Teveles, 1965: Diurnal variation of wind, pressure, and temperature in the stratosphere. Journal of Applied Meteorology, V (5): pp. 632-635.
- Fletcher, R. D., 1969: Comments presented at the AMS Symposium on Meteorological Observations and Instrumentation, Feb.



- Fried, D. L., 1969: Remote probing of the optical strength of atmospheric turbulence and of wind velocity. Proceedings of the Institute of Electrical and Electronics Engineering, 57 (4): pp. 415-420, April.
- Fritschen, L. J., 1969: Particular problems of instrument design and overall development of systems for agricultural and climatological stations. Paper presented at the AMS Symposium on Meteorological Observations and Instrumentation, Feb.
- Fujita, T., G. Baralt, and K. Tsuchiya, 1968: Aerial measurement of radiation temperatures over Mt. Fuji and the Tokyo areas and their application to the determination of ground- and water-surface temperatures. Journal of Applied Meteorology, 7 (5): pp. 801-816.
- Giraytys, J., 1962: Investigations into the variation and distribution of relative brightness on TIROS-I photographs. Final Report, Weather Bureau Contract Cwb-10037, April.
- Giraytys, J., and A. Heck, 1968: Some relevant early events and the United States participation in an international precipitation gage comparison program. Weatherwise, 21 (5): pp. 198-202.
- Gjessing, D. T., 1968: Simple instrument for the measurement of fine scale structure of temperature and humidity and hence also the refractive index of the atmosphere. Journal of Scientific Instruments, London, Ser. 2, 1 (2): pp. 107-112.
- Hall, F. F., Jr., and H. Y. Ageno, 1968: Lidar investigations of the spatial distribution and sizes of droplets in spray plumes from ocean waves. Proceedings, 13th Conference on Radar Meteorology, pp. 518-523, Aug.
- Hardin, V. S., 1966: Characteristics of an air droppable automatic weather station. WMO Technical Note #82 (WMO No. 200. TP. 104): pp. 116-119.
- Hardy, K. R., and I. Katz, 1969: Probing the clear atmosphere with high power, high resolution radars. Proceedings, Institute of Electrical and Electronics Engineering, 57 (4): pp. 468-480, April.
- Hexter, P. L., and R. H. Waters, 1968: The AMOS-III-70 automatic observing station. Bulletin AMS, 49 (9).
- Hexter, P. L., and S. Spivey, 1969: Instrumentation for meteorological observations of importance to hydrology and climatology. Paper presented at the AMS Symposium on Meteorological Observations and Instrumentation, Feb.
- Hicks, J. L., 1967: Clear air turbulence simultaneous observations by radar and aircraft. Science, 157 (3790): pp. 808-809.
- Hilleary, D., D. Wark, and D. James, 1965: An experimental determination of atmospheric temperature profiles by indirect means. Nature 205, pp. 489-491.
- Hilton, R. P., and N. E. Hoag, 1966: Weather radar remoting system. Proceedings, 12th Conference on Radar Meteorology, pp. 91-97, Oct.
- Hinzpeter, M. F. E., 1969: Problems and status of worldwide development of upper air sounding systems. Paper presented at the AMS Symposium on Meteorological Observations and Instrumentation, Feb.
- Hosler, C. L., 1969: The role of weather modification in the alleviation of drought. Earth and Mineral Sciences, 38 (7), April.
- Hubert, L. F., and A. Timchalk, 1969: Estimating hurricane wind speeds from satellite pictures. Monthly Weather Review, 97 (5): pp. 382-383.
- Hunter, P. A., 1968: Analysis of VGH data from one type of four-engine turbojet transport airplane during commercial operations. NASA Technical Note D-4330, Feb.
- Ishimaru, A., 1969: Fluctuations of a focused beam wave for atmospheric turbulence probing. Proceedings, Institute of Electrical and Electronics Engineering, 57 (4): pp. 407-414, April.
- Kahle, D. A., 1967: Digital airborne meteorological data collection system. Report No. 1 for AFCRL Contract F 196 28-67-0101 (D276 Scr), June.
- Kantor, A. J., 1968: Cloud detection capability of operational AN/TPQ-11 radar sets during 1966-1967. AFCRL Instrumentation Papers, No. 142, May.
- Klieforth, H., 1967: Specifications on accuracies required and on parameters to be measured in meso- and microstructural flight investigations. NCAR Technical Note No. 29, pp. 45-51, July.

- Kobayashi, J., 1967: Lower troposphere radiosonde. Papers in meteorology and geophysics, Tokyo, 17 (4): pp. 300-311.
- Lally, V. E., 1969: Constant level balloons for sounding systems. Paper presented at the AMS Symposium on Meteorological Observations and Instrumentation, Feb.
- Leviton, R., and W. Hafford, 1969: General concepts in rawin systems. Paper presented at the AMS Symposium on Meteorological Observations and Instrumentation, Feb.
- Lhermitte, R. M., 1968: New development in doppler radar measurements. Proceedings, 13th Conference on Radar Meteorology, pp. 14-17, Aug.
- Little, C. G., 1969: Acoustic sounding of the lower atmosphere. Paper presented at the AMS Symposium on Meteorological Observations and Instrumentation, Feb.
- Loreny, D., 1967: Temperature measurements from aircraft over land and sea surfaces. Pure and Applied Geophysics 167, pp. 197-220.
- McCallister, J. P., and J. L. Teague, 1968: Radar requirements for operational hydrologic analyses. Proceedings, 13th Conference on Radar Meteorology, pp. 416-421, Aug.
- McFadden, J. D., and J. W. Wilkerson, 1967: Compatibility of aircraft and shipborne instruments used in air-sea interaction research. Monthly Weather Review, 95 (12): pp. 936-941.
- McLean, G., 1965: Investigation into the use of temperature gradients as an in-flight warning of impending clear-air turbulence. Environmental Research Papers 85, AFCRL, pp. 65-117.
- Merritt, E. S., 1967: Studies of TIROS and Nimbus radiometric observations. Allied Research Associates, Inc., Contract NAS 5-10151 final report, March.
- Merritt, E. S., and W. P. Smith, 1968: Satellite-observed characteristics of severe local storms. Final report, Allied Research Associates, Inc., Contract E-202 67 (N), April.
- Mount, W. D., A. C. Anway, C. V. Wick, and C. M. Maloy, 1968: Capabilities of millimeter wave radiometers for remotely measuring temperature profiles pertinent to air pollution. Final report Contract No. PH 86-67-76 for Meteorology Section, National Center for Air Pollution Control, Feb.
- Nelson, E., 1966: Recent developments in high altitude meteorological balloons. 4th AFCRL Scientific Symposium, Proceedings, Sept.
- Nordberg, W., 1968: Inference of properties of the earth from satellite measurements of infrared emission. Paper in "Thermophysics of space craft and planetary bodies." Academic Press.
- Nordberg, W., and W. Smith, 1964: The rocket grenade experiment. NASA Technical Note D-2107.
- Paulson, W. H., 1968: Use of the AN/FPS-77 for quantitative weather radar measurements. USAF Cambridge Research Laboratories Instrumentation Papers No. 137, Jan.
- Pettit, K. G., 1967: Airborne instrumentation for a cloud physics research project. National Research Council of Canada Report 9978, Oct.
- Reiter, E. R., 1967: Measurement of air motions by aircraft. NCAR Technical Note No. 29: pp. 7-15, July.
- Rider, N. E., 1969: Simple, reliable, inexpensive instruments for land area use. Paper presented at the AMS Symposium on Meteorological Observations and Instrumentation, Feb.
- Roberts, W. O., 1969: Benchmark stations for the measurement of presently missing parameters. Paper presented at the AMS Symposium on Meteorological Observations and Instrumentation, Feb.
- Shiners, W., 1969: Status of instrument development for specialized marine observations. Paper presented at the AMS Symposium on Meteorological Observations and Instrumentation, Feb.
- Simpson, J. S., 1966: Hurricane modification experiments. Proceedings, American Society for Oceanography Hurricane Symposium, pp. 255-292, Oct.
- Smith, W. L., 1969: Statistical estimation of the atmosphere's geopotential height distribution from satellite radiation measurements. NESC Technical Note 48, Feb.

- Smith, P. L., and J. H. Boardman, 1968: A real-time radar data processing system. Proceedings, 13th Conference on Radar Meteorology, pp. 310-313, Aug.
- Staein, D. H., 1969: Passive remote sensing at microwave wavelengths. Proceedings of the Institute of Electrical and Electronics Engineering, 57 (4), pp. 427-439, Apr.
- Strangeways, I. C., and J. S. G. McCulloch, 1965: A low priced automatic hydrometeorological station. Int. Ass. Sci. Hydro. Bulletin 10 (4): pp. 57-62.
- Sumner, C. J., 1965: A long period recorder for wind speed and deviation. Quarterly Journal of the Royal Meteorological Society 91, pp. 364-367.
- Sumner, C. J., 1966: A sunshine sensing device for long period recording. Quarterly Journal for the Royal Meteorological Society 92, pp. 567-569.
- System Development Corporation, 1969: National data program for the marine environment. Final report for National Council on Marine Resources and Engineering Development, Contract No. N000 14-67-C-0559, May.
- Tepper, M., and S. Ruttenberg, 1969: Application of space technology to observing systems. Paper presented at the AMS Symposium on Meteorological Observations and Instrumentation, Feb.
- Vizee, W., E. E. Withe, and R. T. H. Collis, 1969: Lidar observations of airfield approach conditions: an exploratory study. Journal of Applied Meteorology, 8 (2): pp. 274-283.
- Vogt, H., 1968: Visibility measurement using backscattered light. Journal of Atmospheric Sciences 25 (5): pp. 912-918.
- Wark, D. Q., and E. E. Fleming, 1966: Indirect measurements of atmospheric temperature profiles from satellites, Part I, Introduction. Monthly Weather Review, 94 (6): pp. 351-362.
- Wark, D. Q., and D. T. Hilleary, 1969: A successful test of remote probing of the atmospheric temperature. To be published in Science.
- Warnecke, G., L. J. Allison and L. L. Foshee, 1968: Observations of sea surface temperatures and ocean currents from Nimbus II. Space Research, Amsterdam, Vol. 8: pp. 1016-1023.
- Wexler, R., A. C. Chmela, and G. M. Armstrong, 1967: Wind field observations by doppler radar in a New England snowstorm. Monthly Weather Review 95 (12): pp. 929-935.
- Wilk, K. E., and E. Kessler, 1969: Quantitative radar measurements of precipitation. Paper presented at the AMS Symposium on Meteorological Observations and Instrumentation, Feb.
- Wilson, J. W., 1968: Accuracy of radar measurements of heavy rainfall. Proceedings, 13th Conference on Radar Meteorology, pp. 374-377, Aug.

## GROUND-BASED METEOROLOGICAL OBSERVING SYSTEMS IN THE 1970's

Andrew S. Carten, Jr.  
Aerospace Instrumentation Laboratory  
Air Force Cambridge Research Laboratories (OAR)

An attempt is made to anticipate Air Force ground-based observational systems which will be in use or which will come into being in the next decade. Present capabilities are examined against probable mission support requirements. All of the major types of ground-based instrumentation, including indirect probes and balloon and rocket sounding systems tracked from the ground, are surveyed and design trends are forecast. Several specific critical requirement areas are examined in detail, and probable solutions are given.

### I. Introduction

It is a pleasure and a challenge to join my distinguished colleagues here today in forecasting the meteorological resources and capabilities of the next decade. Although my presentation will be biased towards Air Force ground-based observational systems, the approaches suggested may be of interest to all affected agencies. Certainly the problems posed by the new, soon-to-be-with-us breed of aircraft are of universal concern.

My forecasts will have an understandable degree of uncertainty since they will be based on an anticipated state of the art and on probable operational requirements. Even quite accurate technical foresight will not automatically cause the observational systems mentioned to materialize, however. The fleshing out of these concepts depends heavily on the solution of the research and development lag time problem, with which most of you are familiar, and for which the prognosis is not encouraging. The very length of the typical development cycle guarantees that, unless a system is under active consideration today, it has little chance of being implemented operationally in the next decade.

### II. Meteorological Support Missions - Present and Future

a. Present-day Mission Support. Since new observational systems come into being principally in response to requirements for specific mission support, any crystal ball gazing in this area must be linked to reasonable estimates of missions to be supported. Thus, a short overview of the anticipated Air Force and Air Weather Service posture over the next ten years should precede detailed system discussions. As a starting point, let us briefly examine the observing function of the Air Weather Service today. It is quite diffuse, yet three distinct missions stand out upon examination, covering support to the following operations:

- (1) Multi-purpose fixed and rotary wing aircraft operations - landings, take-offs, en route conditions, and terminal or target conditions.
- (2) Missile and space flight operations - launch, reentry, and recovery.
- (3) Tactical air and Army field unit operations.

b. Air Force Direction in the 1970's. Will the mission support roles just described persist? The answer to this question depends on our ability to predict the direction which the Air Force itself will take in the 1970's. I see no drastic change. There will still be fixed and rotary wing aircraft, plus space and missile operations, and today's counterinsurgency type of operation will continue in fact or as a possibility. The main thrust will be towards the introduction of much more sophisticated aerospace vehicles whose size, high speeds, and critical performance characteristics will quickly accentuate the deficiencies in present atmospheric analysis and forecasting services. This will result in a clamor for improvements.

In many cases, the new vehicles will be traversing levels of the atmosphere largely unused and inadequately probed at the present time.

c. Improved Interface with Data Processing and Display Systems. The needed improvements will require not only more frequent, more widespread, more accurate, and sometimes new observations but also more rapid dissemination and display of the observed parameters. This includes inputs to aircraft on the final approach, some of which will be under the control of airborne computers. (1) Automatic data gathering systems are a key element in this process. They call for both a very large development effort and a subsequent huge capital investment. It was on the latter point that previous attempts at automation have foundered. Whether new, more reliable, less maintenance prone, solid state modules of today will make the needed capital investment a more saleable issue is a moot point. For the purposes of this presentation, a decision in favor of some sort of automatic data collection and dissemination set is assumed. It would be compatible with the specific observational systems to be discussed.

Fourth generation computers, such as the Illiac IV (2) being planned to upgrade numerical weather forecasting services will employ parallel modes of data processing and will have voracious appetites. To realize the enormous potential of these machines, the interface of the envisioned automatic data acquisition systems with high speed communication lines will have to be planned with extreme care.

The data acquisition, processing, and dissemination goals just mentioned are also goals of the World Weather Watch and the Global Atmospheric Research Program (GARP) which will be in effect during the 1970's. (3) It is likely that these two programs will have a powerful influence on the observational process and provide the impetus for major improvements that has been lacking for much of the past decade.

d. Impact of Weather Modification. Weather modification, both intentional and inadvertent, will also gain prominence in the years ahead, especially as the findings of Project GARP filter down. The routine observing function will have to be expanded to include measurements by which the effectiveness of local modification operations may be gauged. At the same time, care will have to be taken to segregate measurements of the modified environment from those of the natural environment so that synoptic observations will not be misleading and climatological records will not be contaminated. It seems unlikely that intentional local modification processes, such as fog dispersal, will become so efficient and so widely employed in the 1970's that bad weather operations will disappear. Some progress in that direction is very probable, however.

e. Outlook for Mission Support. From the foregoing, it seems safe to conclude that today's support missions will, indeed, persist and will actually become more difficult to carry out in the face of an intensified demand for weather observations. Some measurements will remain manual and relatively crude but most must see a significant degree of refinement. Bigger, faster, higher flying, and more sophisticated vehicles are going to require more accurate, more timely, and more copious data whose acquisition and dissemination will need to be highly automated - to match the real time needs of user control and display systems and to provide adequate grid point information for the new, numerical weather computers.

### III. Surface Measuring Equipment, General Considerations

a. Mission/Configuration Relationships. In discussing specific ground-based operational systems, let us look first - in rather broad terms - at those which will be making direct measurements of conventional surface parameters such as wind, visibility, and temperature. In this area especially, the mission being supported has traditionally influenced the design of the observational tool. On this basis, we can make some safe, general predictions. For example, at permanent airfields and test ranges, there will be a growth in the use of relatively large and very accurate devices with outputs adaptable to automatic processing, and, by contrast, equipment for tactical use will remain small, relatively non-automatic and only moderately accurate. Consequently, the inventory of the 1970's will contain surface

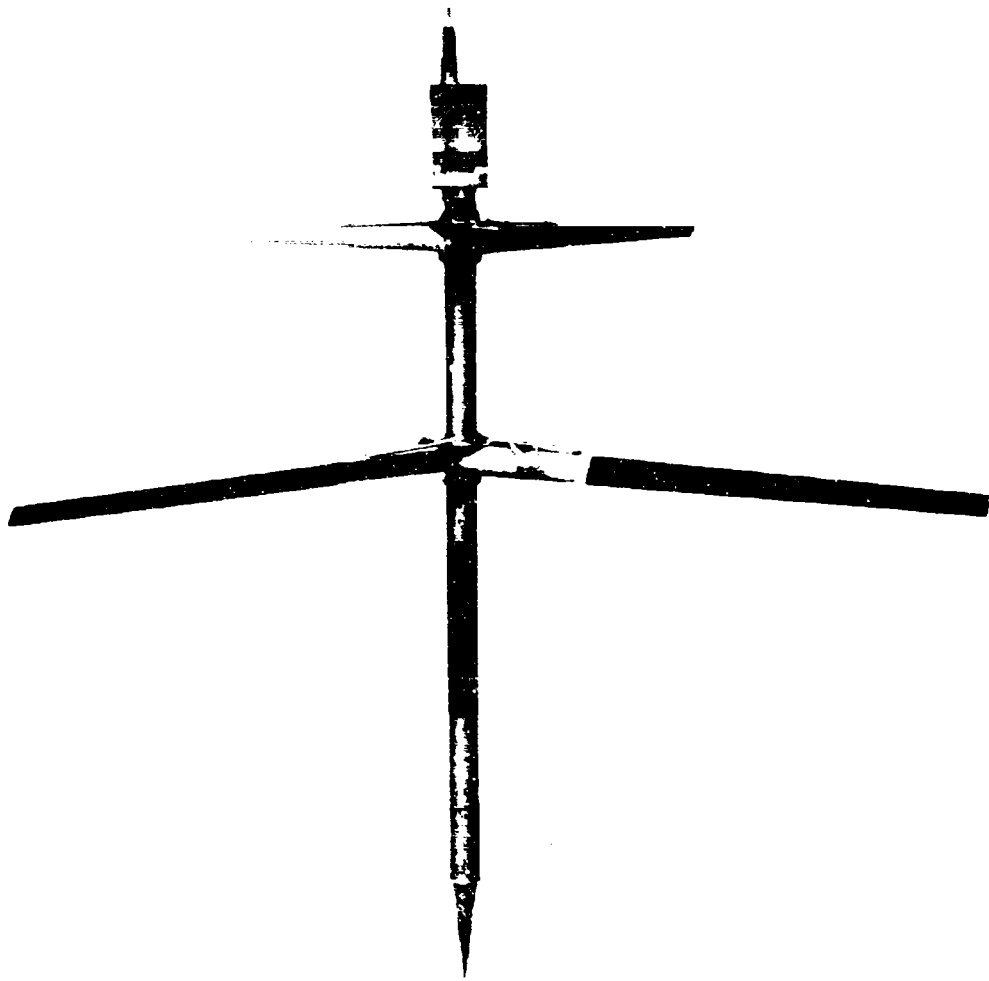

Figure 1. TAMS (Tactical Automatic Meteorological Station)

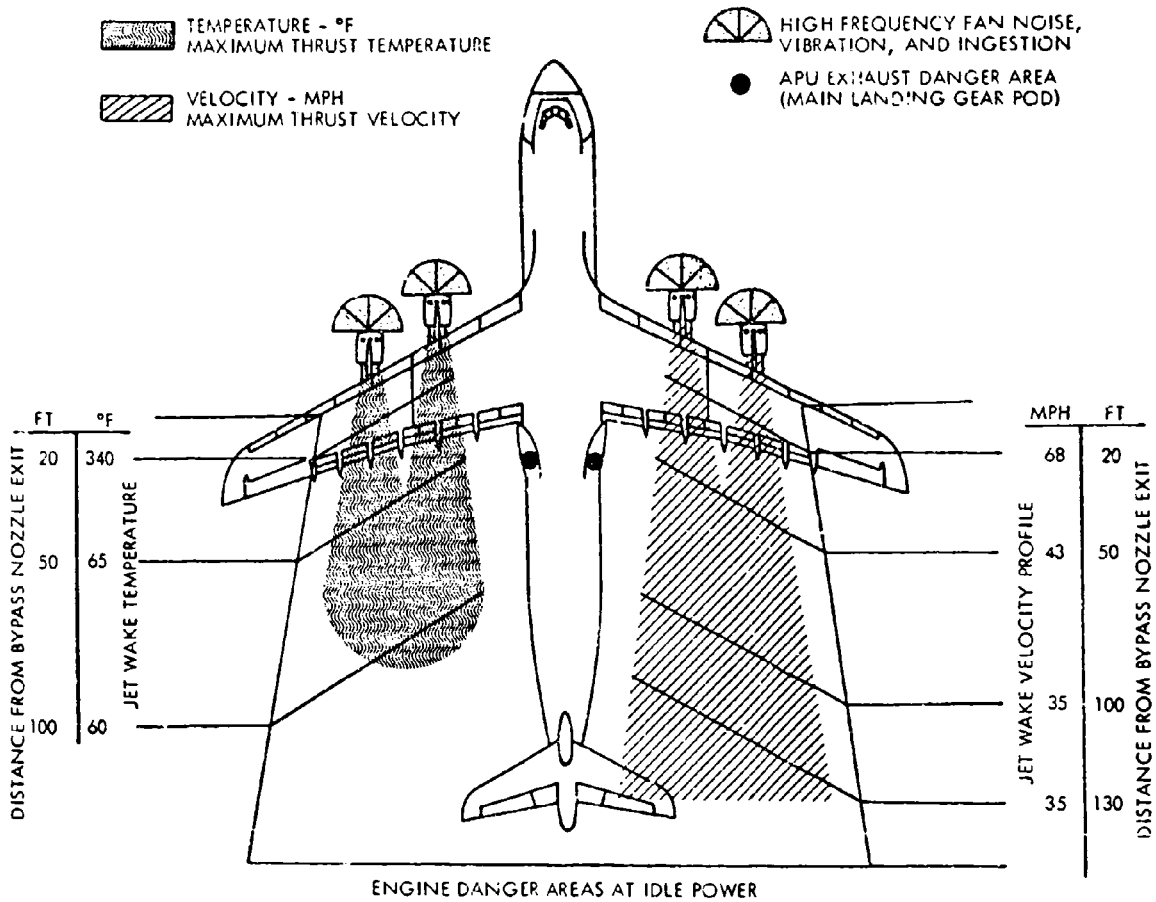

Figure 2. C5A Exhaust Danger Areas, Idle Power

# DANGER AREAS

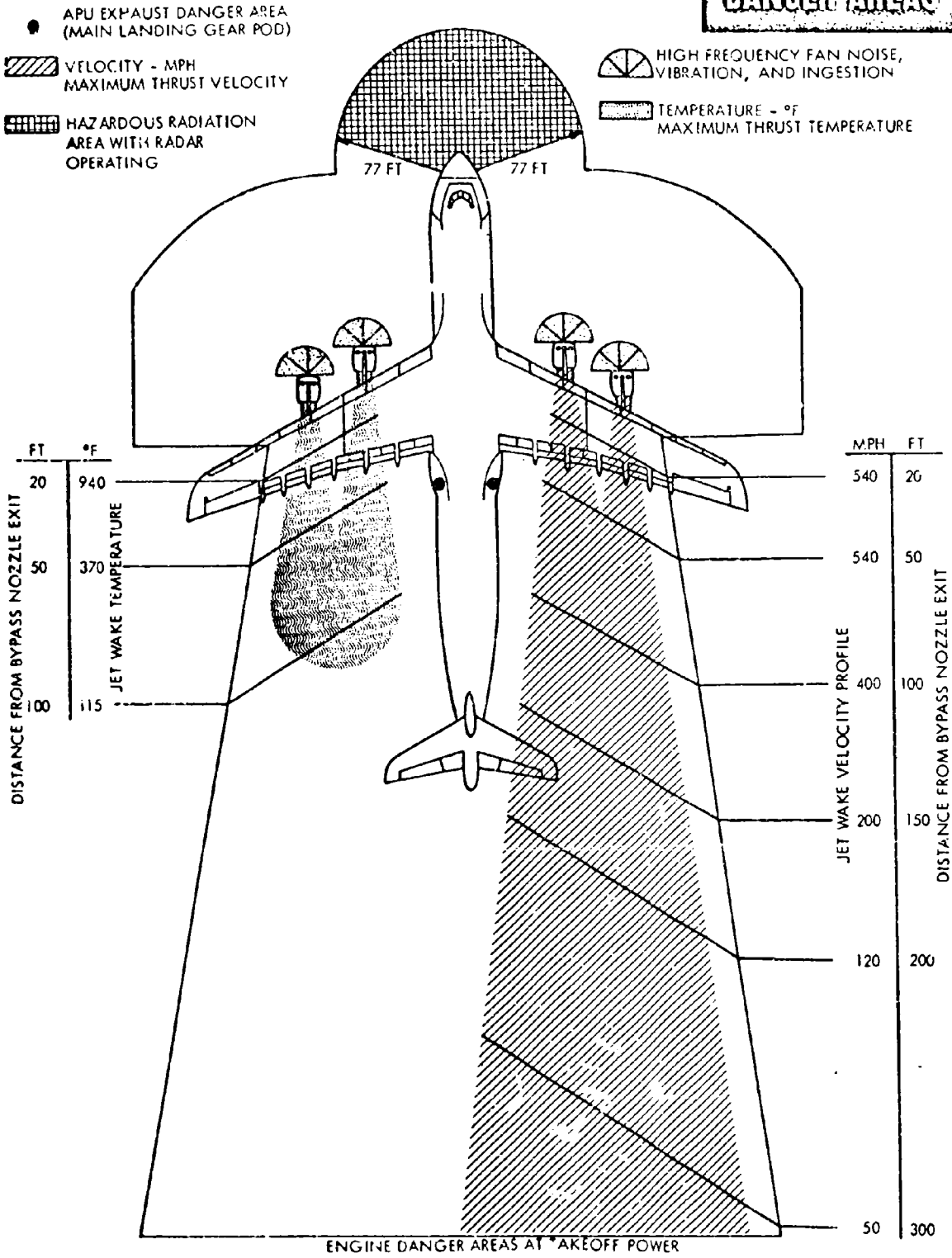

Figure 3. C5A Exhaust Danger Areas, Takeoff Power



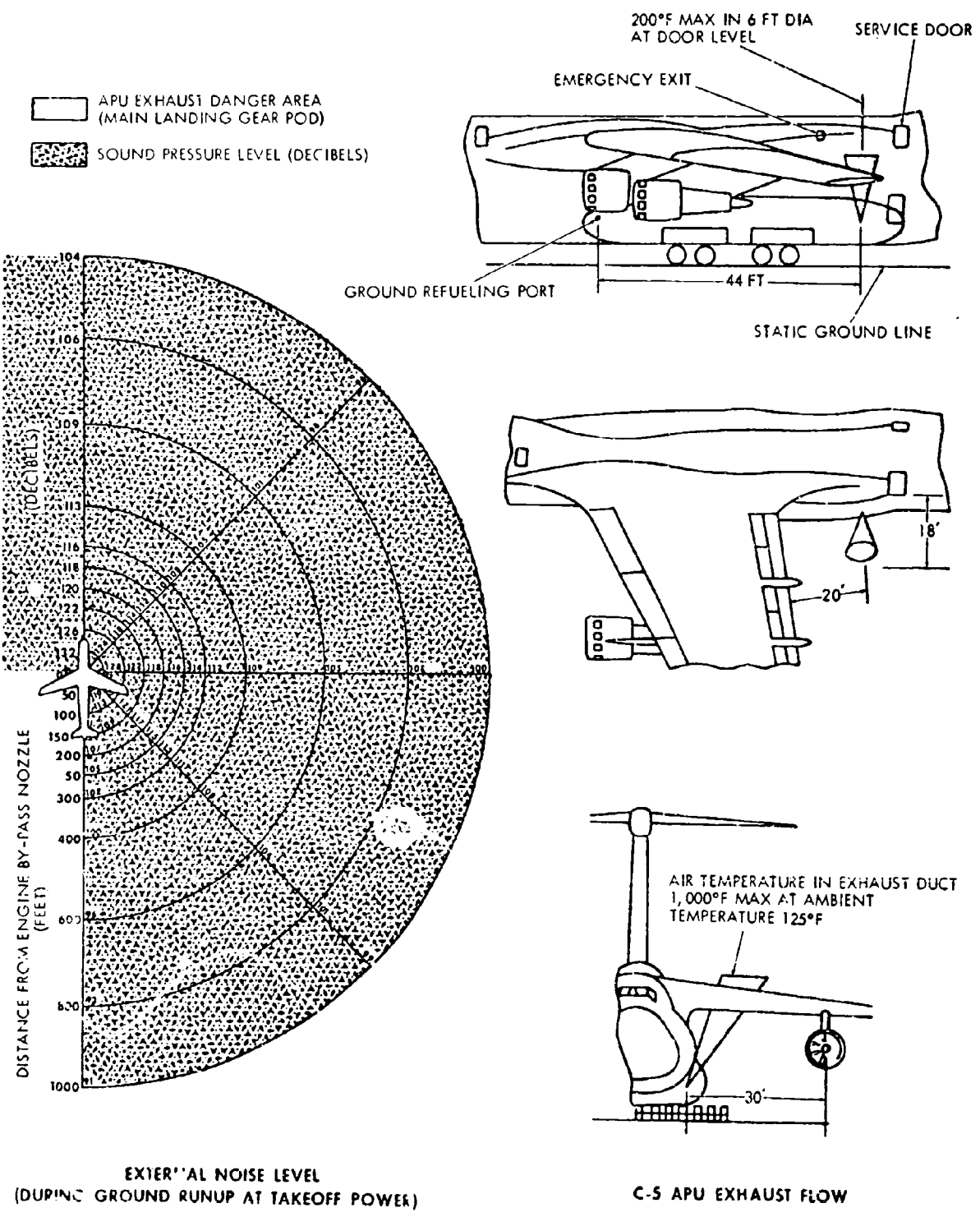

Figure 4. C-1A Exhaust Danger Areas

observing instruments of many different configurations, several of them designed to measure the same parameters. Some will have rather unique configurations, one example being the air droppable automatic weather station whose development is underway at AFRL. (FIGURE 1). I will concentrate on airfield configurations in this discussion. Specialized tactical and test range instrumentation deserves comparable treatment, but time just does not permit it.

b. Operational versus Meteorological Observations. I would like now to distinguish between synoptically-reported meteorological or station measurements, which are used to define pressure patterns, frontal locations, and local climatology, and operational measurements which are used primarily for control purposes. An example of the latter would be the updated wind values furnished to pilots to assist aircraft movements. Runway Visual Range (RVR) is also such a measurement. Another safe prediction is that, at many airfields, in the years to come, the instruments used for station measurements can no longer be those also used for operational measurements as the latter readings become increasingly unacceptable for meteorological use. This will come about primarily because of the previously-mentioned intentional or inadvertent local weather modification process. This news is certainly not startling from a technical viewpoint, but the prospect of added and remoted sensors poses problems with respect to real estate, cabling, (or microwave relays), capital investments, maintenance, and data handling.

c. Impact of the New, Very Large Aircraft Engines

(1) Engine Thrust Values, Old and New. The exhaust wakes of the new, very large aircraft engines coming into use are a prime candidate for the inadvertent local weather modification role. The power ratings of these gigantic thermodynamic machines are very impressive. Whereas present first-line fighter, bomber, transport, and cargo aircraft employ engines in the 18 - 21,000 pound thrust class (4), the on-coming vehicles such as the Air Force C-5A Cargo plane and the commercial Boeing 747 Transport have engines with better than double thrust levels of 41 - 45,000 pounds. (5) The same is true of the forthcoming trijet airbus. Growth versions of these engines will surely exceed 50,000 pounds. (6) The Anglo-French Concorde SST engines will be in the 35,000 pound class. (7) The American SST will be powered by 63,000-pound thrust engines. (7) The significance of these numbers is illustrated by FIGURES 2, 3, and 4 which show the jet wake temperature and exhaust velocity profiles of the C-5A at idle and take-off power settings.

(2) Typical Air Force Base Traffic. I am assuming that the other new aircraft mentioned above have profiles similar to that shown for the C-5A. Even though the Air Force may not own a 747, an airbus, or an SST, aircraft of that type will be operating under contract to MAC as a matter of course and will be sharing runways with the C-5A and other standard Air Force planes. Actually, Air Force One will be an SST in due time and the replacement for SAC's B-52's will employ similar large engines.

(3) Effect on Local Observations. It is obvious that these aircraft can generate intense localized streams of hot air and low level turbulence. In recognition of this fact, the management at O'Hare Airport has already given notice that the 747 may have to be towed between the end of the runway and the terminal area to avoid damage to structures and injury to people. (8) It has been demonstrated that the much less powerful C-141 cargo plane, when deployed in small numbers at a fog-bound airfield can, in a few minutes of full-power engine operation, improve visibility along the runway. (9) The C-5A, the airbus, and the 747 have a much greater capability in this respect. The important issue, however, is the impact of their exhaust streams on airfield observations in normal operations when a variety of power settings will be employed. Consider, for example, the trijet airbus. Its center-mounted engine will be 20 - 30 feet above ground. (8) The frictional dissipation of this engine's exhaust will be certainly less rapid than for lower-mounted engines. What will be the effective length of its wake? Is it ridiculous to suppose that a pilot of one of these aircraft could sharply increase RVR values, and "open" a closed airfield, by aiming his exhaust towards the transmissometer in use?

(4) The Question of Representative Measurements. The purpose of airfield operational measurements is to tell the pilot and the tower operator the conditions under which take-off or landing operations will be carried out. The information passed on should be representative.

Will off-the-runway sensors be capable of gauging residual turbulence and thermal reservoirs along the runway meaningfully? Will the taxiing operations of the jumbo jets contribute so much interference noise to the system as to make the observations meaningless? Will the sensors be damaged by these operations? Will serious levels of pollution (e.g., water and carbon) be introduced? The dissipation of these intense pockets of energy would appear to be a function of the local environment and of the frequency at which it is contaminated. An occasional C-5A movement at Edwards AFB on a cool, windy day will patently have less impact than the rush-hour 747 and airbus traffic at O'Hare or Kennedy Airport on a sultry summer day. At the very least, the new large aircraft will bring about a critical review of the surface parameter measurement function at airfields. The most optimistic forecast is that they will prove no problem as a result of the judicious use of ground control procedures. A less sanguine finding appears more likely, however.

#### d. V/STOL Aircraft Support

(1) Growth in V/STOL Utilization. It is important here not to lose sight of another new class of aircraft with its own peculiar set of wind and temperature sensitivity problems. This is the fixed-wing V/STOL class which is also on the horizon. Small STOL aircraft are operational today at both military and commercial fields, and the British have an operational VTOL fighter. American employment of a VTOL fighter in the years ahead appears likely in view of the controversy over the vulnerability of conventional aircraft at forward area bases. Another trend will be towards larger and more diversified STOL aircraft. The commercial exploitation of STOL aircraft is needed to help solve the air traffic problem and the increased military use of this type of vehicle for forward area resupply missions seems assured. The problems associated with STOL aircraft will be most severe in the commercial area, the outstanding one being that of acoustic noise because of the extra thrust demanded by these high drag machines. (10)

Air traffic congestion leads naturally to the mechanism of traffic separation. In the commercial area, two trends are emerging. One is the isolation of small sections of major airfields for STOL operations. The other is the creation of mini-airports, such as those proposed for New York City's waterfront. In either case, it is necessary that the STOL landing areas have their own nav aids and meteorological instrumentation. Comparable trends at military airfields are anticipated. As a minimum, we can expect a quantitative increase in meteorological observation systems to support military and commercial V/STOL operations, regardless of any qualitative changes. Changes in the latter category will also be required as will be developed later in this discussion.

I should like now to concentrate on specific surface parameters, opening with a discussion of wind measurements.

#### IV. Surface Wind Measurements

a. Low-level Shears. The measurement of surface wind is such a time-honored function that the law of diminishing returns might seem to apply with respect to development work in that area. Actually, the opposite is true especially if we stretch the meaning of the word "surface" to include the lowest 1500 feet of the atmosphere. This extension can readily be justified because of the inapplicability of surface wind measurements to higher points along the aircraft landing glide slope. Undetected and unsuspected large wind shears, as in the case of the low level jet phenomenon, offer a serious hazard to incoming aircraft. (11) Even fairly close to the surface, the need for change becomes evident upon comparing projected operations with current capabilities.

b. The Jumbo Jet Influence. From the previous discussion of the impact of the new large engines, there is a serious question as to whether present-day methods of observing surface winds will continue to be representative or operationally useful. I believe that changes will be needed, but the nature of these changes will have to await the test of experience.

c. V/STOL Operations. With respect to our other new class of vehicles, I find V/STOL operational problems difficult to define, mainly because of rapid advances in the state of the art. However, one very recent assessment of the situation is that the V/STOL stability and control

problems in the transition stage are still present and show very little signs of disappearing. <sup>(12)</sup> The main problem seems to be flow separation from some parts of the lifting system, an effect which depends on configuration, Reynolds number, and interference velocities from the ground or other parts of the aircraft. It is in the matter of calculating interference velocities from the ground that wind measuring instrumentation is likely to play a major role. Thus, the critical effect of low level winds on STOL and VTOL aircraft operations will almost certainly require specialized wind measurements. Conversely, the destructive downwash of these vehicles will have to be monitored to alert personnel on the ground against hazardous conditions and to prevent damage to surface structures. (Recent developments in ground-based sonic anemometers have found their way into V/STOL aircraft operations. One model has been adapted to, and tested on, the XC-142 experimental aircraft.)

d. Probable New Wind Sensors. It seems likely, then, that the relatively simple anemometer system employed at the typical Air Force base will become an anachronism. At the very least, it will be necessary to spot a number of rugged sensors at critical locations and to feed the outputs to a central point. Where such sensors can be affixed to hangers or towers, no state of the art advance will be required. There will be a need for new sensors, however, with respect to the measurement of winds in areas where no structures can be tolerated, such as along the glide slope. These measurements will be needed more often than can be economically or practically provided by pitot tubes or by low level radiosonde systems. A promising approach - although it is not an all weather system - in an electro-optical one in which natural or induced quantities of aerosols or other scatterers are sampled remotely by a light beam and doppler motion of these particles is translated into wind motion. (This is really an indirect method of measurement, but it appears appropriate to mention it here, in advance of the main discussion of indirect probes.)

#### V. Surface Temperature and Dew Point Measurements

The measurement of surface temperature and dew point has already become almost completely automated. The aspirated and radiation-protected shelter is standard, both in the Air Force and in the Weather Bureau. This arrangement lends itself readily to automatic data storage and transmission and is seen as a standard item during the next decade. The probable major change will be the replacement of the lithium chloride dew point sensor with the thermoelectrically cooled dew point mirror. This type of sensor has been demonstrated repeatedly to have superior accuracy and reliability and to lack the bias associated with the chemical sensor. <sup>(13)</sup> The changeover is inevitable in view of the need for better fog forecasting ability to support the new high performance aircraft. It is probable, too, that a single humidity temperature sensor location will no longer suffice for an airfield and that, as in the case of wind, a complex of sensors will have to be installed.

#### V. Surface Visibility Measurements

a. The Problem. RVR is one of the most critical parameters from an operational point of view and, yet, it has perhaps, been measured least efficiently of all surface parameters. (Incidentally, I am excluding from this presentation any discussion of prevailing visibility on the grounds that it is not operationally significant in today's predominantly IFR mode of operation - despite its importance to climatologists. RVR, on the other hand, opens and closes airfields and its importance will increase greatly as the numbers of passengers and the tons of cargo carried on board Air Force and civilian aircraft increase.) With the relatively high performance C-141 and C-9 aircraft and their commercial counterparts already on hand and with the C-5A, the 747, the airbus, and the SST just around the corner, the ante in the poor visibility landing game is being raised. <sup>(14)</sup> Despite the publicized development of all weather landing systems, the successful and safe day-to-day operation of the new vehicles will continue to depend in large measure on the ability of the pilot to see, particularly during the last hundred feet of the landing operation. The very size and inertia of the large new aircraft make them less responsive timewise to required changes in the vertical flight path. <sup>(15)</sup> <sup>(16)</sup> This sluggishness in pitch response means slower rotations at take-off, longer glide paths, and, most importantly, reduced ability to climb out from an aborted landing operation. Thus, the pilots of these aircraft will want no surprises when they are down to the decision point. <sup>(17)</sup> The droop-nose, high angle flare of the SST would appear

to be especially critical in this respect. The current flurry of activity to develop ILS independent monitoring systems (18) for use in Category II and III poor visibility landings signifies the need for greater pilot assurance and tranquility in the cockpit. It is hoped that a cockpit display system will emerge from these efforts which will give the pilot an accurate electronic image of the landing zone ahead, despite the obscuration to visibility, and thus reduce his dependence on visual sighting. A high resolution, on-board  $K_a$  band radar system might provide such an indication. This, combined with automatic landing systems, may eventually obsolete the requirement for RVR measurements for aircraft so equipped. For the present, however, we must assume that visibility problems will be an important factor for some time.

b. A New Method of Measuring Runway Visibility. There appears to be no rational basis for assuming that the present system of measuring runway visibility or calculating runway visual range on the strength of a single transmissometer installation can be perpetuated. Multiple instrumented runways appear to be the only feasible answer to measuring visibility meaningfully at airports in the 1970's. These installations would feature several new visibility sensors spaced along paths parallel to critical runways and feeding into a simple panel display of visibility conditions by runway sector. This would clearly eliminate today's very dangerous situation wherein patches of fog on a runway are not detected because they do not penetrate the relatively small area under transmissometer surveillance. Although the 500-foot baseline of the transmissometer represents only 5% of the length of a 10,000 foot runway, current procedures can apply the reading from this small sector to the whole airfield. To achieve the proposed new configuration, an inexpensive very short baseline visibility sensor needs development and a system which exploits scatter techniques appears most promising. (AFCL is exploring the feasibility of this approach at the present time.) Such a system should be able to be calibrated and to maintain its resolution under conditions of poor visibility - capabilities which the present transmissometer system does not have. Deploying these sensors may be a problem if they are not to be "spoofed" by passing large-engine aircraft.

## VII. Indirect Measuring Equipment

a. Definition. I should like to turn now to another class of instrumentation which is employed for making observations very closely associated with the surface parameters just discussed. I refer to indirect measuring equipments which, by definition, are devices which sample a volume of the atmosphere at a distance. They accomplish this by electro-optical or electro-magnetic probes or, in some cases, by employing passive receivers for detecting incoming energy over a wide variety of electrical and optical frequencies. A very common example is the ceilometer which employs a searchlight beam and triangulation methods to detect cloud bases. Another example is the storm detecting weather radar set.

b. Slant Range Visibility. The urgent requirement to measure visibility along the glide path, referred to as slant range visibility, stands a good chance of being satisfied through a combination of laser and computer technology. (19) (AFCL and the FAA are currently initiating an experimental investigation of the feasibility of such a system.) The same technology is being applied to overhead cloud base measurements, and we may see a gradual replacement of the somewhat cumbersome rotating beam ceilometer with a laser system. Although the coupling of the slant range visibility measurement to the real world of aircraft landing operations is a step which will require a great deal of experimentation and hard work, the emphasis on Category II and Category III A landings will hasten such experimentation and, if the techniques prove feasible, operational implementation is expected to occur at a rapid pace.

### c. Storm and Cloud Detecting Radar Sets

(1) Vertical Profiling. The weather radar sets being installed at the present time are expected to be used through the next ten years. It is likely that modifications will be introduced periodically, however, to augment the usefulness of these sets. Integrators to improve the signal-to-noise ratio until recently were thought to be in this category. Tests of this modification on the AN/TPQ-11 vertically pointing radar set have shown that too much valuable operational information is lost in the integration process and that the integrator's

greatest usefulness will lie in the research area. While on the subject of vertically pointing radar sets, one hoped-for change in the next decade will be the adoption of this principle by the civilian sector. Despite maintenance problems associated with a marginal transformer design, this set - in Air Force use - has amply demonstrated its unique capability to display vertical cloud structures, icing levels, the onset of precipitation, wind shears, frontal passages, and various other parameters of operational significance. The wealth of information provided by this set is too valuable to be denied to civilian airport users much longer.

(2) Rainfall Intensity Measurements. An interesting development in connection with increased radar utilization is the measurement of rainfall rates. A nomogram has been developed for the AN/FPS-77 Storm Detecting Radar which allows quantitative measurement of the radar reflectivity or "Z". (20) This factor is a function of the number and size of droplets in a given volume and should prove a useful tool in studying local climatology and analyzing storm rainfall characteristics. Field use of this tool awaits user experience and application.

(3) Convective Turbulence Measurements. Weather radar researchers at AFCRL have recently demonstrated (21) an experimental doppler radar system called the Plan Shear Indicator. This set, which employs a coherent memory filter, detects "cloudy" air turbulence, wind shears, sinks, and vortices. It is a completely new system and would have to replace or supplement existing sets if brought to an operational status. It represents one approach to the problem of vectoring aircraft around or through possibly dangerous convective clouds in the vicinity of an airport. With the large number of turbulence-sensitive T-tail jets in service, such information could be most valuable.

(4) Monitoring of Fog-clearing Operations. Another application currently under development, and potentially an operational system late in the decade, is the use of  $K_a$  band radar for monitoring local fog clearing operations. The frequency to be employed has been highly successful in defining overhead cloud structures when used in the previously mentioned, vertically pointing AN/TPQ-11 Cloud Base Measuring Radar Set. The set contemplated for weather modification monitoring use will have a horizontal scan and should be effective in locating openings created in fog banks and tracking the movement of these openings relative to runways of interest.

(5) Clear Air Turbulence Detection. The experimentation in the use of high powered ground-based radar sets for detecting clear air turbulence aloft has shown a great deal of promise to date. (22) It is anticipated that limited operational use of this technique may be a fact in the 1970's.

(6) Lightning Warning Equipment. The problem of excessive refueling delays at airfields or test ranges threatened by lightning is expected to be eliminated in the near future. After a lengthy investigation of various approaches, (23) (24) developers at AFCRL have concluded that a set which employs a field mill to measure variations in the local electric field and a range-calibrated lightning stroke counter to monitor nearby discharges offers the most useful information. It is an omnidirectional device and requires radar information to provide azimuthal data. A set of this type will be tested at AFCRL later this year and probably at Eglin AFB next year. Fairly widespread operational deployment of this set is anticipated. This set also has a potential for Air Traffic Control vectoring purposes when used in conjunction with radar. In addition, it could provide valuable inputs to the Atmospheric Electricity Ten-year Program which will be underway during the 1970's. (3)

(7) Laser Probes. Mention has already been made of laser ceilometers and laser visibility measuring and wind finding equipment. The ability of the laser to detect aerosol layering associated with temperature inversions has also been demonstrated, (25) and this type of probing is expected to become commonplace in areas where inversions are a problem. Research into the application of laser measurements to high altitude density determinations has been very promising to date, (26) and it is likely that this technique will become employed operationally at one or more locations, where almost continuous monitoring of the mesospheric density variations is required. Although a laser system of this type is restricted to cloud-free conditions, it can produce a very large number of useful measurements at a small fraction of the cost of rocket soundings.

(8) Radiometric Measurements. In closing out our discussion of indirect sensing techniques, mention should be made of radiometric measurements. This area encompasses both infrared and microwave passive receiving systems which sample radiation emitted by the atmosphere. The goal of research investigations in this area has been to provide an inexpensive substitute for the soundings produced by radiosondes or rocketsonde techniques. At the present time, this technique is in the experimental stage, and it is difficult to visualize its reaching widespread operational status during the next decade.

I should like to discuss now the prospects for improvements in the last major category of ground-based observational systems. These are the systems which sound the atmosphere up to 200 kilometers by means of balloon-borne and rocket-borne instrument packages.

#### VIII. Vertical Sounding Systems

a. An Overview. Ground-based vertical sounding systems with expendable flight components will continue to provide much of the data on the state of the atmosphere during the years ahead. The balloon-borne radiosonde, because of its comparatively low cost, will be launched in sizeable quantities by many nations. It is to be hoped that programs like the World Weather Watch will point up the qualitative differences among the various radiosondes used and will lead to proper corrective action. The much more expensive meteorological sounding rockets may show a relative decrease in use despite the better than 50% price reduction recently achieved in this area. This assumes that with improved sensors, our knowledge of the climate of the upper stratosphere and of the mesosphere will be stabilized, reducing the need for repeated measurements. The rocketsonde will not disappear as an operational tool, however. The annual number of launches per site may decrease, but the number of sites will probably increase, for better global coverage. Important stratospheric events (such as an "explosive warming")<sup>(27)</sup> will undoubtedly trigger a barrage of firings from many stations. Firings in support of specific space operations will also add to the total consumption figures. The anticipated deployment of ground-based high altitude laser density measuring systems will, of course, bring about a reduction in these firings.

#### b. Sounding Instrument Telemetry

(1) Radiosondes and Rocketsondes. Since radiosondes and rocketsondes will account for a substantial portion of the instrumentation budget during the next ten years, there exists a ready-made incentive for better and more timely utilization of the valuable data which these instruments can obtain. On the technical side, both types of sonde should become completely solid state about midway in the period. Whether or not they actually go this way will depend on decisions made with respect to proposed <sup>(28)</sup> ground stations. Actually, many solid state research sondes have been built already.<sup>(29)</sup> The principal obstacle to their operational deployment, especially for radiosondes, has been cost. Cost is relative, however, and the need for more accurate data and for more frequent sampling per flight makes more expensive flight systems inevitable, providing that compatible ground stations are in place. In judging this trend, we must consider not only the inflation which has beset the entire economy but also the fact that the system which relies on the simple, vacuum tube, mechanically-switched 1955 model radiosonde can no longer do the job. It is fortunate that the cost curve for solid state oscillators is heading downward so that radiosondes using such components will not be out of reach pricewise when they enter volume production. The impact on the rocketsonde price structure will also be important but less critical. (It is mostly solid state already.) An important fringe benefit resulting from the use of the solid state configuration is the drastic reduction in battery size brought about by their inherent low power requirements. This, coupled with additional decreases in power needs resulting from the narrow-band characteristics of the crystal-controlled oscillators used, means smaller flight packages, a fact which should ease the anxiety of SST pilots traversing the same airspace.

(2) Existing Ground Stations. A typical Air Force radiosonde sounding consists of a flight to balloon burst altitude, about 110,000 feet. Tracking is by a radio theodolite which, in some cases, has an additional ranging capability. Temperature and humidity values are obtained no more often than every 20 seconds. Wind speed and direction values are computed

manually from successive determinations of the balloon's position and are averaged over a two-minute interval. Rocketsonde flights go about twice as high, but tracking and data sampling are comparable to radiosonde procedures except that, with non-transponder models, the addition of a radar set is needed for tracking purposes. Judged against what is both possible and required, these are gross measurements. The techniques employed are, with the exception of ranging, basically those used when the radiosonde was introduced back in the 1930's. The next decade should certainly be the time period for the breakout from the old, long established mold. The tools are at hand.

(3) An Interim Measure - the AN/GMD-4. A partial step has already been taken at the test ranges where the AN/GMD-4 Rawin Set (30) is used to track radiosondes and rocketsondes and where data reduction has become virtually automatic. The AN/GMD-4 is not the final answer, however, since its ranging system - although superior to that of the older AN/GMD-2 - cannot discriminate adequately against spurious signals such as those introduced by noisy mechanical radiosonde commutators. The AN/GMD-4 is also incompatible with the standard non-transponder radiosonde, and thus, its versatility is limited.

(4) An Advanced Meteorological Sounding System. It has been demonstrated at AFCRL that it is possible to obtain a much finer grained profile of the atmosphere and to do this with improved accuracy and almost completely automatically. Despite higher instrumental costs, the experimental system to which I am referring is actually more economical in terms of useful data acquired than the older systems which are in use today and whose continued use is guaranteed for the next five to six years. Called the Advanced Meteorological Sounding System (AMSS), (31) it is, in our opinion, the most effective replacement for today's GMD-1, GMD-2, and GMD-4 Rawin Sets. It is a radio theodolite in the same tradition as the sets it would replace and it, too, has a transponder ranging capability (FIGURE 5).

The advantage of the AMSS lies in the availability of more modern techniques for the execution of the basic principles. Its design benefits from the sometimes bitter experiences with today's sets. It also borrows liberally from the technical fallout from space exploration. Competitive systems proposed by the other agencies have been evaluated and are deemed to have considerable merit, but they are not ideally suited for the broad Air Force mission.

Much work must be done soon if the required improvements are to come about in vertical sounding methods. The administrative mechanism for the transition from prototype to operational system is complex and beyond the scope of the present discussion. Suffice it to say that the critical atmospheric data needs of the upcoming years will not be met unless there is a ground swell of demand for implementing the vastly improved techniques which are on hand and are ready for final development.

(5) Capital Investment Considerations. The proposed new sounding system will mean a major capital investment. Present day rawin sets lack compatibility with the new techniques and are not considered sufficiently reliable to serve as the basis of a large scale modification effort. On the positive side, the new system will receive data from all contemplated Air Force radiosonde and rocketsonde flights and, by feeding into on-site or centralized computer systems, will completely eliminate the manual reduction of data which is both costly in manpower and susceptible to error. Compared to previous standards, the amount of data obtained per flight will be enormous because of the extra channel capacity of the new system and the faster sampling rates employed. Its use will be limited only by the ability of the computer or the connecting transmission lines to handle such data. The new techniques are also adaptable to such specialized systems as AFCRL's Low Level Sounding System (29) and the Refractive Index Sounding System (32) which are already in, or approaching, the operational stage.

c. Other Flight Components. In the years ahead, there will also be a commensurate increase in the performance of items used with or in support of these sounding systems: faster rising balloons, higher flying balloons and sounding rockets, less radiation sensitive thermistors, more accurate pressure and density sensors etc. This is an area which has been fairly well covered in other papers (33) (34) (35) and I shall not go into it here. (36) (37) (38)



## IX. Conclusion

Thus far, I have attempted to depict the probable operational conditions under which the Air Weather Service will be carrying out its ground-based observational role over the next decade. The problems enumerated represent one man's point of view. There are certainly other problems of an economic and sociological nature which could drastically alter my predictions. There may, for example, be social rejection of the new aircraft because of air and noise pollution, airways congestion or airport saturation - problems which are outside the scope of this paper. I do not expect this to happen, but the creaking, overburdened condition of today's airways certainly suggests the possibility. We shall probably muddle through the social problems and the technical efforts associated with the safe and efficient operation of the new aircraft will be our primary concern.

In many respects, our position today is not unlike that of the 1958 - 1959 time period when jet aircraft were beginning to enter the inventory in substantial numbers. Many unknowns faced meteorologists and other members of the aerospace community then because of the lack of experience with the new vehicles. We have survived that decade, although mistakes were made and some lessons were learned the hard way. The sensitivity of the jets to clear air turbulence and the need to develop new flying techniques to cope with the problem is perhaps the most outstanding example. Ambitious plans were undertaken during that time period (39) to automate the meteorological observing system, plans which included features resembling many of the things advocated in this presentation. The fact that ten years have gone by without realization of these plans in no way diminishes their need. The years lost, in fact, make the job harder at this time since the new jet aircraft are likely to be less tolerant of the older observing system.

The next ten years will be busy ones for the entire meteorological community. As one deeply involved in the development process, I urge all who are concerned about the future of meteorological observations to make their wishes effectively known so that the development efforts which are the prerequisite of any improved operational systems can receive the needed attention and support. Without such representations, today's slow pace will be maintained or decelerated even more and the technology required to do the job ahead will simply not materialize.

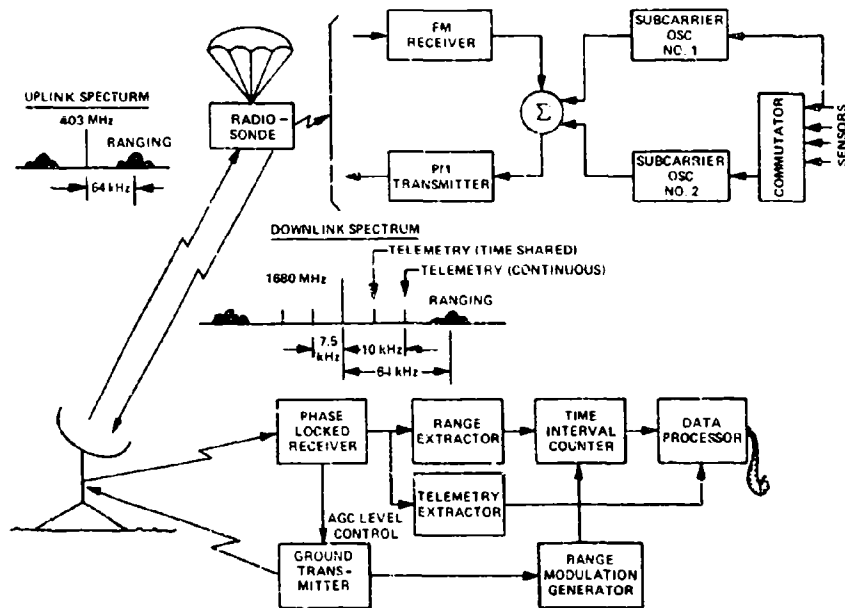

Figure 5. AMSS Block Diagram

#### REFERENCES

- (1) Johnston, A.M., 1969, "Total In-Flight Simulation", PERSPECTIVE, Cornell Aeronautical Laboratory, Inc., 1st Qtr 1969, pp 3-9.
- (2) Perry, J.S., Major, 1969, "Fourth Generation Computers and the Air Weather Service", AEROSPACE SCIENCES REVIEW, AWS RP 105-2, No. 69-1, pp 2-7.
- (3) Tilson, S., 1969, "Electricity and Weather Modification", IEEE SPECTRUM, Vol. 6, No. 5, pp 89-101.
- (4) Scholin, A.R., 1968, "A Gallery of USAF Weapons", AIR FORCE AND SPACE DIGEST, Air Force Association, Vol. 51, No. 9, pp 204-214.
- (5) 1969, "Aerospace In Perspective - TRANSPORTATION", SPACE/AERONAUTICS, Conover-Mast Publications, Vol. 51, No. 1, pp 76-83.
- (6) 1969, "New RB.211 Offered for L-1011 Growth Version", AVIATION WEEK & SPACE TECHNOLOGY, McGraw-Hill, Vol. 90, No. 17, p 26.
- (7) Hersch, P., 1969, "The SST: Future Questionable", SCIENCE & TECHNOLOGY, International Communications, Inc., No. 88, pp 36-45.
- (8) 1969, "Giant Jet Exhaust Problems Expected", AVIATION WEEK & SPACE TECHNOLOGY, McGraw-Hill, Vol. 90, No. 16, p 27.
- (9) Coons, F.G., Jr., Capt., 1968, "Project Warm Fog", TECHNICAL REPORT 209, Volume 1, AWS, pp 5-20.
- (10) Levin, S.M., 1969, "Building Blocks for the Next Subsonics", SPACE/AERONAUTICS, Conover-Mast Publications, Vol. 51, No. 5, pp 70-78.
- (11) Barad, M.L., 1961, "Low-Altitude Jet Streams", SCIENTIFIC AMERICAN, Vol. 205, No. 2, pp 120-131.
- (12) Joppa, R.G., 1969, "Wall Interference Effects in Wind-Tunnel Testing of STOL Aircraft", JOURNAL OF AIRCRAFT, Vol. 6, No. 3, pp 209-214.
- (13) Weiss, B.D., 1968, "Error Analysis of the Humidity-Temperature Measuring Set, AN/TMQ-11", AFCL-68-0154.
- (14) 1969, "Landing Jumbos in Low Visibility: A Pilot Protests", ASTRONAUTICS & AERONAUTICS, AIAA, Vol. 7, No. 5, pp 58-60.
- (15) Soule, H., 1969, "Jumbo-Jet Certification: DOC and Safety", ASTRONAUTICS & AERONAUTICS, AIAA, Vol. 7, No. 6, pp 26-29.
- (16) Lamar, W.E., 1969, "Military Aircraft - Technology for the Next Generation", ASTRONAUTICS & AERONAUTICS, AIAA, Vol. 7, No. 7, pp 56-62.
- (17) Halsby, N.E., May 1968, "All-Weather Operations - Progress and Challenges", ASTRONAUTICS & AERONAUTICS, AIAA, Vol. 6, No. 5, pp 63-69.
- (18) Klass, P.J., 1969, "New Radar Landing Techniques Explored", AVIATION WEEK & SPACE TECHNOLOGY, McGraw-Hill, Vol. 90, No. 20, p 32.

- (19) Viezee, W. and E.E. Uthe, Stanford Research Institute, Scientific Report No. 1, August 1968 (Contract AF19628-68-C-0021), "Analysis of Lidar Data Obtained Under Conditions of Low Ceiling and Visibility", AFCRL-68-0522.
- (20) Paulsen, W.H., 1968, "Use of the AN/FPS-77 for Quantitative Weather Radar Measurements," AFCRL-68-0013.
- (21) AFCRL RESEARCH BULLETIN, May 1969, "New Radar Technique for Detecting Cloudy Air Turbulence".
- (22) Glover, Boucher, Ottersten, and Hardy, "Radar, Aircraft and Meteorological Investigation of Clear Air Turbulence", 13th Weather Radar Conference, AMS, 20-23 August 1968.
- (23) Weiss, B.D., 1967, "The SPARSA Atmospheric Electricity Detection System as Modified by the Addition of the Image Storage Tube Electro-Optical Triangulation Computer, Part 1", AFCRL-67-0183.
- (24) Weiss, B.D., 1968, "An Analysis of the Performance of the Three-Station SPARSA Network for Detecting and Tracking Thunderstorm Activity", AFCRL-68-0272.
- (25) Viezee, W. and J. Oblanas, Stanford Research Institute, Final Report (Contract No. F19628-68-C-0021), 15 November 1968, "Lidar-Radar Lower Atmospheric Observations", AFCRL-68-0586.
- (26) Kent, G.S. and R.W. Wright, University of The West Indies, Scientific Report No. 22, 1969, "A Review of Laser Radar Measurements of Atmospheric Properties".
- (27) Webb, W.L., 1966, STRUCTURE OF THE STRATOSPHERE AND MESOSPHERE, Academic Press, pp 143 and 169.
- (28) Griggs, W.M., Motorola, Inc., Final Report (Contract F19628-67-C-0319), 15 September 1968, "AMSS Prototype Radiosonde", AFCRL-68-0475.
- (29) Ramirez, R.G., R.J. Betz, J.R. Casey, Bendix Corp., Final Engineering Report (Contract AF19(628)-5117), "Development of a Low Level Sounding System", May 1967, AFCRL-69-0225.
- (30) 1968, Sonex, Inc. "Instruction Manual for Meteorological Data Processor, Type 3703E", (Contract F19628-68-C-0360).
- (31) Griggs, W.M. and J.K. Wood, Motorola, Inc., Scientific Report No. 2, 15 September 1968, (Contract AF19(628)-4215), "An Advanced Meteorological Sounding System, Phase II (PROOF-OF-CONCEPT)", AFCRL-67-0268.
- (32) Spitzer, J.W., 1969, Fairchild Hiller Corp., Final Report (Contract F19628-67-C-0157), "Refractive Index Sounding System (RISS)", AFCRL-69-0054.
- (33) Sharenov, M., 1969, "New High Altitude Fast-Rising Balloon", ECOM-3100, USAECOM.
- (34) Bollermann, B., R.L. Walker, Space Data Corp., Final Report (Contract AF19(628)-5921, 28 February 1968, "Meteorological Probe PwN-8B", AFCRL-68-0132.
- (35) Bollermann, B., R.L. Walker, Space Data Corp., Final Report (Contract AF19(628)-5911, 30 June 1968, "Design, Development and Flight Test of the Viper Dart Robin Meteorological Rocket System", AFCRL-68-0418.
- (36) Morrissey, J.F., A.S. Carten, Jr., 1967, "Importance of Thermistor Mount Configuration to Meteorological Rocket Temperature Measurements", BULLETIN OF THE AMERICAN METEOROLOGICAL SOCIETY, Vol. 48, No. 9, pp 684-688.
- (37) Wexler, A., 1969, "Measurement of Humidity in the Free Atmosphere Near the Surface of the Earth", PROCEEDINGS OF SYMPOSIUM ON METEOROLOGICAL OBSERVATIONS AND INSTRUMENTATION,

American Meteorological Society (to be published in late 1969).

(38) Hyson, P., 1968, "Thermistor Mountings", JOURNAL OF APPLIED METEOROLOGY, AMS, Vol. 7, No. 5, pp 908-918.

(39) White, R.M., R.F. Myers, F.W. Ward, Lt Col G. A. Guy, 15 December 1957, AFRC Technical Note 57-609, "General Design for Weather Observing and Forecasting System, 433L", (AD #133 8461).

## METEOROLOGICAL RECONNAISSANCE SYSTEMS OF THE 1970's

Richard G. Chappell  
Air Weather Service

The meteorological recon systems of the 1970's will continue to be plagued with the age old problems of the lack of definitive requirements and the capability to determine the absolute accuracies of the various sensors. Both Air Force and Navy weather recon systems are programmed for significant technological advances in the early 70's. It is hoped that some farsighted people will be equally concerned with the development of new standards, testing procedures and applications of the data to make the high cost of new hardware development justified.

a. As a preface to my comments on the meteorological reconnaissance systems of the 1970's, I will spend a few minutes reviewing present airborne equipment and its capability.

(1) The Air Weather Service weather reconnaissance fleet currently consists of 14 WC-130(), 10 WC-135B, 7 RB-57C, 19 RB-57F and 24 WB-47E aircraft. The WC-130s are primarily utilized for tropical storm detection, penetration and analysis missions. During non-storm season periods, synoptic weather tracks, cold fog dispersal, and special atmospheric sampling missions are flown. The WC-135B aircraft, the military version of the familiar Boeing 707, primarily perform atmospheric sampling missions. However, these missions are generally flown on a synoptic basis from which much weather data are obtained. These tracks include an over-the-pole mission flown daily between Alaska and England. The RB-57 aircraft are used almost exclusively for atmospheric sampling although temperature and doppler wind data are obtained on a synoptic basis. Support for thunderstorm and clear air turbulence experimental programs is provided upon USAF direction. The WB-47 is used primarily as a weather scout for inflight refueling and fighter deployments, and support of AFSC downrange operations.

(2) The WC-130 aircraft is presently capable of obtaining ambient temperature, pressure and absolute altitude and doppler winds in the horizontal mode. The APN-59 search radar is utilized for storm contour analysis and navigation. In the vertical mode, temperature, pressure and relative humidity are obtained from flight level to the sea surface utilizing the AMT-6 dropsonde. The respective sensors used include the ML-419 rod thermistor, a pressure bellows and the ML-476 carbon humidity element. The sonde falls at a rather slow 1500 ft/min, has a peak pulse power output of 140 watts and transmits on 403 mcs. The pulse modulated sonde signals are fed into the AMR-1 or AMR-3 dropsonde receptor which records the data on a strip chart from which interpretations of the measured parameters are made. Both horizontal and vertical data are manually worked up by the dropsonde operator and the weather officer. After review of the finalized data for obvious errors and the addition of pertinent observer remarks, such as sea state, cloud observations, etc., the data are transmitted to air-ground stations by HF single sideband voice, for further dissemination to the ultimate users. Horizontal observations are taken every two hundred nautical miles on a typical mission with vertical profiles obtained every four hundred nautical miles. Typhoon and hurricane missions involve penetration into the eye at 10,000 ft. altitude. A sonde is dropped in the eye to determine sea level pressure and vertical temperature gradients.

(3) The AMQ-25 meteorological system, installed on the WC-135B aircraft, is the most completely automated airborne weather reconnaissance system currently in operational use. Horizontal sensors include wind speed and direction, ambient temperature, radar and pressure altitude. A wind vector computer utilizes inputs from the compass, airspeed and doppler radar to compute North-South and East-West wind speed vectors. Temperature is obtained via the Rosemount probe, and absolute altitude is obtained from the APN-42A

radar altimeter. Vertical data, including pressure, temperature and humidity profiles, are presently obtained with the AMT-13 dropsonde. This unit is a pulse modulated device which transmits on the 403 mcs. Its peak pulse power is 18 watts. Sensors include the ML-405A rod thermistor, the ML-476 carbon humidity element and a pressure bellows, similar to that used in the AMT-6 dropsonde, except that it moves on a wiper arm across a wire wound resistor providing a continuous analog output. Both horizontal and vertical raw data are processed through the IBM CP-821 digital computer. At each weather reporting position, all horizontal and vertical data are transmitted to air-ground stations via 100-word-per-minute SSB radio teletype in RECCO code format. Should the computer fail at any time during a mission, the system is switched to a bypass mode during which all raw data in the horizontal or vertical plane are printed out for manual reduction.

(4) The Naval Weather Service operates a reconnaissance fleet of 15 WC-121N constellations. These aircraft are employed primarily for tropical storm reconnaissance and meteorological research programs. Hurricane and typhoon penetrations are made at low level and vertical soundings, using the AMT-6 dropsonde, are obtained. The Navy and Air Force storm reconnaissance units support each other in the tracking of tropical storms, providing a more continuous observation of these phenomena. The equipment on the WC-121N consists of a PRT-4A airborne radiation thermometer, an AMQ-17 Aerograph set, used primarily for temperature, the SCR-718 and APN-159 radar altimeters, MA-1 pressure altimeter, the FA-112 barometer, an AMQ-3 Vortex thermometer and the C-3 Cambridge Dewpoint Hygrometer. The APN-153 doppler radar is used for determining flight level wind data. In addition to an AMT-6 dropsonde capability, the SSQ-36 bathothermograph probe is air-dropped to obtain profiles of sea temperatures to a depth of 1000 feet. An air-launched rocketsonde is under development. All data are processed through the Data Acquisition Logging System which provides a mix of automatic and manual inputs for either visual or recorded displays. Data outputs along with visual observations are recorded and/or transmitted automatically in digital form. All air-ground transmissions are via 100 word-per-minute HF radio teletype.

(5) It is not uncommon knowledge that most operational airborne weather sensors are well behind the state-of-the-art. The ML-476 humidity element, as a prime example, has been in operational use for almost every conceivable application ranging from balloon sondes and dropsondes to flight level aircraft sensors. Despite its long history of use, the actual performance and washout characteristics of the element are essentially undefined in the real world environment. Needless to say, temperature measurement capabilities and developments have far outstripped the rod thermistors, presently used as sonde temperature sensors in both response time and accuracy.

b. To meet the increasingly stringent environmental data requirements of the 1970's and beyond, Air Force Systems Command is currently undertaking Project 5222, Advanced Weather and Reconnaissance System. This program is designed to equip all the AWS WC-130 and WC-135 aircraft with state-of-the-art sensors, sounding devices and electronic data processing systems. According to the current schedules, acquisition of the first system is expected in calendar year 1973, however this is very optimistic. The program is broken down into two acquisition phases. The first is designed to vastly upgrade our present capability with sensors and subsystems that are available off-the-shelf or presently nearing completion of engineering development. The second phase will be a longer term sensor development program to replace or add new capabilities as they are developed. The heart of this next generation system will, of course, be the data processing subsystem. It is to be designed to provide the operator with complete control of the system, yet not be tied down with details of its operation. The system must be extremely flexible and expandable to accept new sensors and subsystems as they become available from the R&D community. We will continue to use radio teletype as the air/ground

transmission mode until common user satellite communications are available. RECCO code will also be used, however, some of the improved accuracies and new parameters will be reported in the remarks section until code changes can be accomplished. The computer software will actually operate the system using FORTRAN or a similar familiar programming language. In the sensor area, temperature, pressure, and radar altitude, flight level dewpoint, turbulence intensity and flight level wind speed and direction will be measured.

(1) Some of the new sensors are currently in the engineering development phase. Air Force Systems Command has a contract with Meteorology Research, Inc. to fabricate two prototype systems to objectively measure the intensity of encountered turbulence independent of aircraft characteristics and aircrew interpretation. Should this system prove successful during the flight tests scheduled for late this summer, it will be available for acquisition into the AWARS program. To obtain the required wind speed and direction accuracies, a small scale inertial platform will be used to provide aircraft reference, without the errors of wave motion. The system is to include accurate determination of the heights of cloud tops and bases, and to fly outside a hurricane or typhoon and be able to fully define the shape and location of the eye and wall clouds. This latter would not only provide for a better visual picture of the storm's severity but would permit the identification of the safest path for penetration into the eye.

(2) Requirements for vertical profile data from sea surface to 600,000 feet are also to be satisfied by the 5222 program. As you know, we are presently unable to obtain any data above flight level and cannot provide wind profile data below the aircraft. Hence, a combination of dropsondes and rocketsondes is envisioned to resolve these deficiencies. Current developments indicate that wind sensing may be incorporated into a standard dropsonde with minor changes. Beukers Laboratory, under Weather Bureau contract, is developing a technique whereby a sonde's drift can be accurately tracked utilizing either the Loran C or OMEGA navigational techniques. Work is also underway by Honeywell, under AFPCRL contract, to develop a separate windsonde. Although their technique appears promising, cost per sonde may prove prohibitive. The air-launched rocketsonde will be used to obtain vertical profiles from 600,000 feet to the surface. Several independent rocketsonde sensor development programs are underway.

(3) The second phase of AWARS, estimated for the late 70's and early 80's time frame, will incorporate remote sensing techniques, including measurements of complete vertical profiles, thus replacing dropsondes and rocketsondes. Remote CAT detection is also foreseen during this period and should be readily incorporated into the system. Naturally, there are many requirements which will not be satisfied under 5222 but are currently receiving a great deal of scientific attention. Weather modification is a prime example. During two seasons of operational testing, super-cooled fog dissipation from WC-130 aircraft has been successfully performed in both Alaska and Europe. Work is already underway for development of a standardized cold fog dissipation system and should be completed for the 1971 winter season. Seeding to produce rain and to decrease tropical storm intensities is presently being undertaken by AWS, ESSA, the Navy and many civilian agencies. Before such techniques reach truly operational stages, we must be capable of measuring such parameters as moisture content, particle size, and probably a few parameters which are yet to be determined. It seems likely that vast improvements in fine scale measurements may be required to achieve optimum results.

(4) The list of agencies conducting research into remote measurement techniques of atmospheric phenomena is almost endless. However, the Navy is doing a great deal of work in the remote measurement of sea temperatures and sea state using infrared methods. They are restricted to lower altitudes using the current equipment due to haze and clouds. The development of airborne sensors has been severely limited for the past 20 years in

that the meteorologist has not been able to state and prove, objectively, the effect of varying degrees of inaccuracy on the final weather product.

c. In closing, there is one final area that I feel requires immediate attention. All meteorological sensors installed on aircraft are severely limited in value because there is no way to know their absolute accuracy in the operational environment. How does one prove that airborne winds are indeed representative of actual conditions, and to what accuracies? How does one know that a dropsonde's 500 mb temperature was really measured at 600 and not 510 mb? We have performed tests on the AFN-42A radar altimeter to determine its accuracy. Optical triangulation on the Western Test Range proved it to have excessive error. However, this technique is subject to its own errors which limit tests to relatively low altitudes. Similar tests using external standards are required for all sensors. These tests, once established, should be used for periodic calibration of all meteorological sensors. This is perhaps the greatest problem now facing the weather reconnaissance program. No matter how tightly the specifications are written, this in itself is no guarantee of operational attainment. I feel that this problem of determining accuracies can be solved, given enough time and money. But, the work must begin now if we are to realize the full value of accurate atmospheric data in the 1970's. To those of you who are already working in this field, I would be most interested in discussing your techniques, theories or even bone-felt hunches. And for those of you who believe the reconnaissance program is unique in this problem of questionable accuracy, I would like to ask two questions:

- (1) Do you know the degree of absolute error in the rawinsonde data you use?
- (2) Can you state objectively the effect in your particular area, or in forecasting in general, of decreasing the error by 50% - or of finding that the error is actually twice as bad as expected.



THE DEVELOPMENT OF METEOROLOGICAL SATELLITES IN THE UNITED STATES  
AND THE OUTLOOK FOR FUTURE SENSING SYSTEMS \*

William Nordberg  
Laboratory for Atmospheric and Biological Sciences  
Goddard Space Flight Center, NASA

I. Basic Concept of Meteorological Satellites

The first series of meteorological satellites were devoted to the day-to-day identification and tracking of weather phenomena such as storms, frontal systems and jet streams on a world-wide and synoptic basis. Observations consisted initially of photographing cloud patterns with television cameras in day-time which were supplemented later by infra-red radiometers to make cloud observations at night. These observations have found prominent application in short-term (2-3 days) weather forecasting. The identification and tracking of weather systems by mapping world-wide cloud patterns began experimentally with TIROS I in 1960.

In a series of nine satellites from TIROS I in 1960 to TIROS IX in 1965, spacecraft technology and data transmission and processing techniques advanced progressively, so that day-time cloud photographs were acquired daily over the entire globe. In February 1966, the launch of ESSA I initiated the series of TIROS Operational Satellites (TOS), which began to carry out global cloud photography operationally and routinely for the United States Environmental Science Services Administration (ESSA).

Very early in the development of TIROS it became apparent that adequate nighttime cloud sensors, such as the High Resolution Infra-red Radiometer (HRIR), and the direct transmission of cloud photographs to local facilities via the automatic picture transmission (APT) system, required a larger, more versatile spacecraft than TIROS. Such spacecraft also had to accommodate experiments not necessarily devoted to the tracking of cloud formations, but rather to exploring the many, as yet, ill-understood processes which are known to have a strong bearing on weather. For example, it was desirable to continue the monitoring of the global distribution of net radiation flux; i.e., the energy difference between solar radiation absorbed and telluric radiation emitted by the Earth's surface and the atmosphere. Such measurements had already been made with EXPLORER VII launched in October 1959 (Weinstein and Suomi, 1961) and with TIROS. Also on TIROS, experiments were developed to infer the stratospheric circulation, global distribution of water vapour and Earth surface temperatures from radiometric measurements. To carry all these experiments and to provide for their continued expansion and development we began, in 1960, the design of the NIMBUS spacecraft. This was an extremely important step, as it permitted us to pursue the implementation of an immediate operational observation system based on TIROS while, at the same time, NIMBUS provided the potential and capability to conduct scientific investigations and to develop sensors and technology which might eventually be employed in a second generation operational system. The operational requirements for acquiring cloud observations to make forecasts were thus kept from interfering with the development of more advanced observation techniques to which NIMBUS, as a versatile and flexible meteorological observatory, was tailored.

One shortcoming of cloud observations with the TOS system could not be overcome with NIMBUS. The observation of small-time-scale meteorological phenomena, such as severe storms, required almost continuous observations of the same area over periods of several hours. Such observations are only possible when made from a spacecraft in geostationary orbit; i.e., from an altitude of about 37,000 km. From that orbit, we observe not only small-scale phenomena continuously, but we also track cloud formations on a synoptic scale more effectively so that in appropriate circumstances we can make wind measurements. For this purpose, two of NASA's Application Technology Satellites (ATS) were instrumented with scanning photometers, so that each satellite produced day-time images of cloud cover over one-third of the globe (McQuain, 1967). The first ATS was successfully launched in December 1966 and has the capability of transmitting a picture of the Earth's disc over the Pacific once every twenty minutes. The other, ATS III, was launched in November 1967 and is capable of transmitting colour pictures

\*Dr Nordberg was unable to give his presentation and Dr. Sherk of his Laboratory spoke in his place. This paper is a reprint with slight changes of Dr. Nordberg's article in *W. M. O. Bulletin*, Jan. 1969, which covers essentially what he would have presented at the Conference.

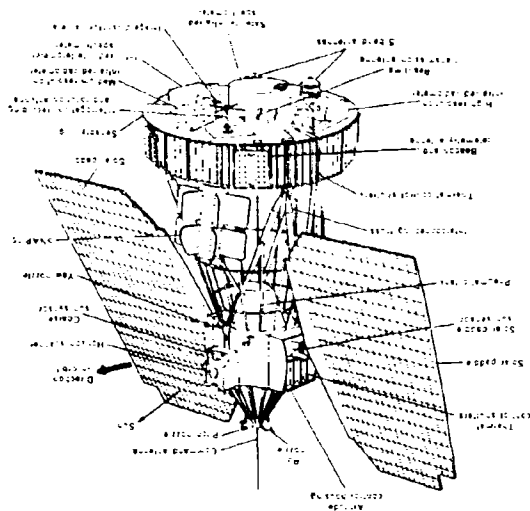

Figure 1. - The NIMBUS III spacecraft

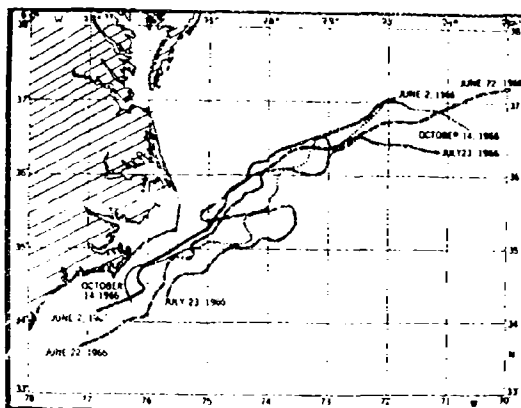

Figure 2. - Gulf Stream boundary positions derived from NIMBUS II HRIR measurements from June to October 1966 (After Warnecke et al., 1967)

at similar intervals for the Atlantic region (Warnecke and Sunderlin, 1967). In contrast to TIROS and NIMBUS, ATS were not developed specifically to make meteorological observations, and they carry several experiments for other purposes. Nevertheless, they plan an important role in our meteorological satellite programme and their cloud-cover observations serve a purpose which could not be fulfilled with the TIROS and NIMBUS satellites.

Because of the great capacity of NIMBUS for meteorological experiments and because of the impact which such experiments may have on future developments of the Global Atmospheric Research Programme (GARP), we shall discuss the NIMBUS concept and system in greater detail.

## II. NIMBUS -- A series of global meteorological observatories

The same, rather sophisticated, basic spacecraft system concept is employed in each of six NIMBUS missions; three of these have been carried out; one other is in preparation for launch during 1970; and two more are being planned for launch after 1971. This basic concept includes: a spacecraft capable of delivering in the order of 200 watts of electrical power to the experiments; a mechanical structure which can accommodate a maximum number of experimental instruments and which can be pointed at the Earth at all times with an accuracy of about  $1^\circ$ ; a stable and moderate thermal environment required by many instruments; a data system which can acquire and store in the order of  $10^9$  to  $10^{12}$  bits per orbit and transmit these data to the ground while passing over Alaska, and in addition can transmit continuously a lesser amount of data. The NIMBUS concept also calls for observation of practically all points on the globe at least twice during every 24-hour period, always at the same local time. This is accomplished by placing the spacecraft into a sun synchronous orbit at a height of about 1,100 km. Thus, the orbit plane is inclined to the equator  $98.7^\circ$  and precesses around the centre of the Earth at a rate that is synchronous with the revolution of the Earth around the Sun. As a consequence, the relative orientation between the orbit plane and the sun remains essentially constant and the satellite crosses the equator always at noon and at midnight.

Although the basic NIMBUS concept remained the same for six spacecraft (Figure 1), many of the spacecraft subsystems are being improved from spacecraft to spacecraft to provide greater accuracy, reliability, or most importantly, to accommodate a changing and every-increasing complement of experiments.

The first two missions, NIMBUS I launched in August 1964 and NIMBUS II launched in May 1966, carried experiments to:

- a. Demonstrate improvements in making high-resolution day-time cloud observations;
- b. Demonstrate the feasibility of high-resolution night-time cloud mapping;
- c. Transmit both day- and night-time cloud images to local receivers;
- d. Map emitted telluric radiation as well as reflected solar radiation, in various spectral bands.

The sensors consisted of:

- a. A set of three television cameras and a tape recorder called the Advanced Vidicon Camera System (AVCS) for day-time cloud photography.
- b. A scanning HRIR to map and image thermal radiation emitted between  $3.4$  and  $4.2 \mu$  by cloud tops or the Earth's surface. On NIMBUS II, HRIR images were transmitted also via the APT.
- c. An additional television camera to transmit day-time cloud pictures via the APT to simple, inexpensive and often home-made receivers.
- d. A scanning five-channel Medium Resolution Infra-red Radiometer (MRIR) to map and image thermal radiation emitted by atmospheric water vapour or cirrus clouds between  $6.4$  and  $6.9 \mu$  by  $\text{CO}_2$  in the lower stratosphere between  $14$  and  $6 \mu$ , by cloud tops or by the Earth's surface between  $10.5$  and  $11.5 \mu$ , and by the Earth's surface as well as the atmosphere between  $5$  and  $30 \mu$ .

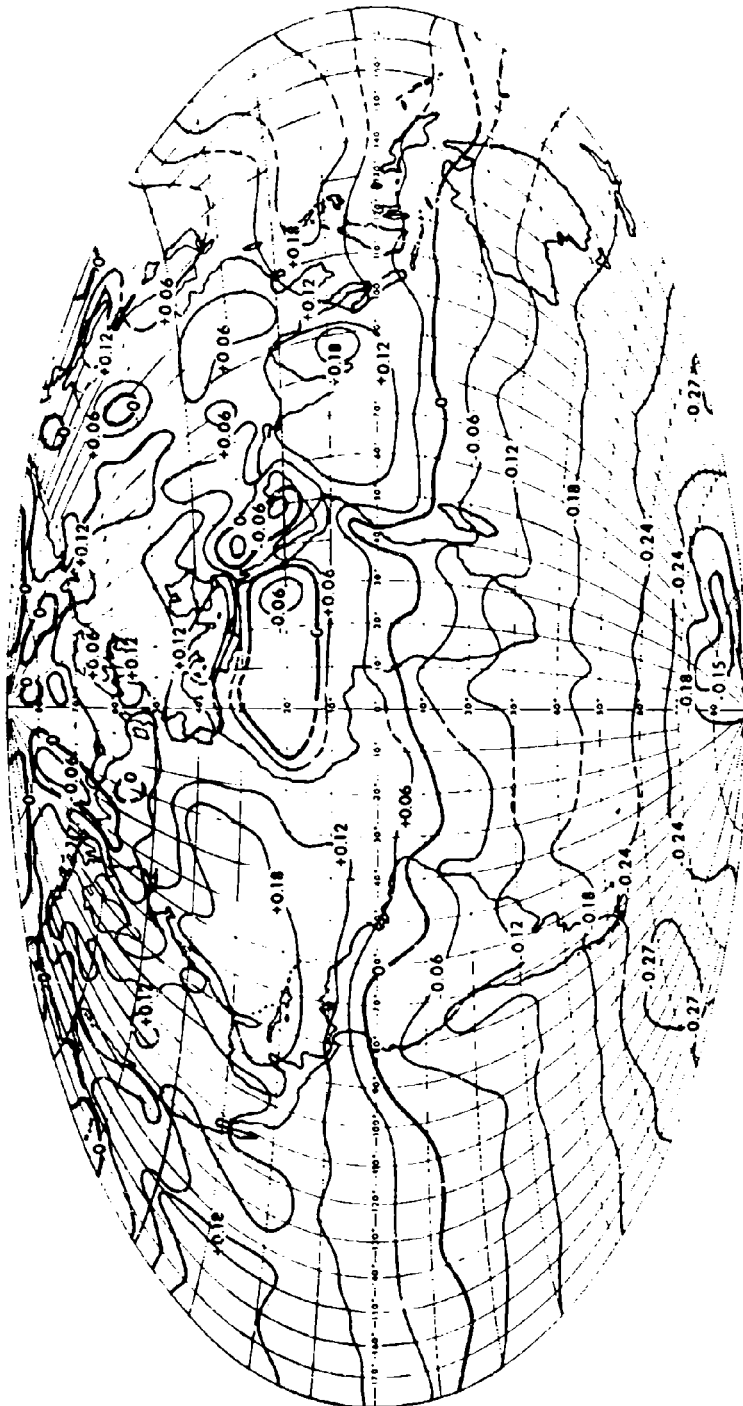

Figure 3. - Net radiation flux ( $\text{cal cm}^{-2} \text{min}^{-1}$ ) during the period 1 - 15 July 1966 observed with NIMBUS MRT. Energy surplus of absorbed solar radiation over emitted long-wave radiation (net downward flux) is found generally north of  $10^{\circ}\text{S}$ . Surplus maxima occur over the relatively cloudless northern subtropical oceans. The large desert areas of North Africa and Arabia, in contrast, show a deficit (upward flux). This deficit is caused by the high albedo (30 to 40 per cent) and by the high surface temperature of those areas. There is also energy deficit over the Arctic land and ice areas. South of  $10^{\circ}\text{S}$ , there is consistent energy deficit. (After Raschke and Pasternak, 1967)

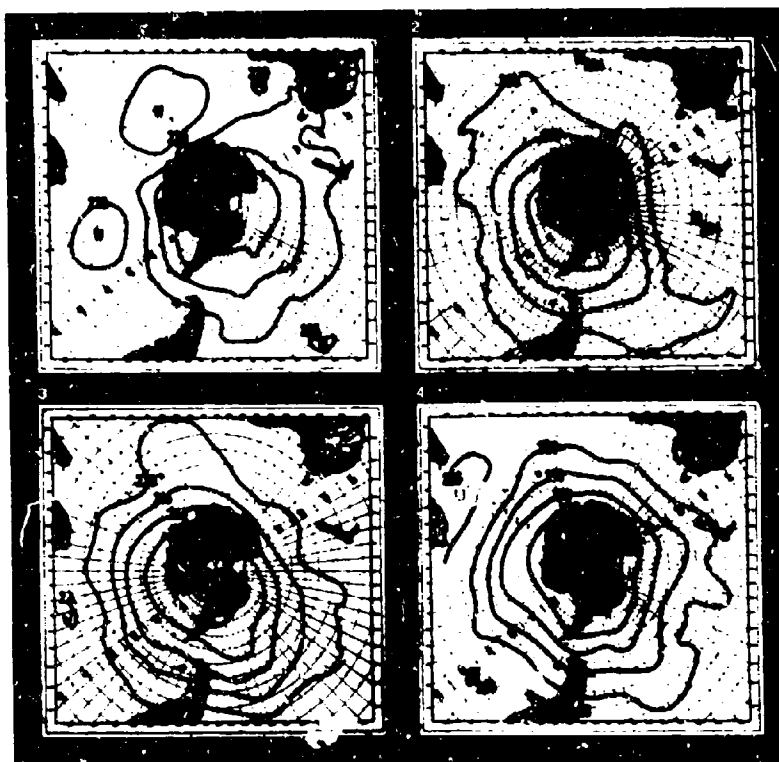

Figure 4. - Radiation emitted in the  $14 - 16 \mu$  band measured by the NIMBUS II MRIR over the southern hemisphere on 21 May, 10 Jun, 11 Jul and 24 Jul 1966. Radiation intensities are expressed as temperatures ( $^{\circ}\text{K}$ ) of a black body emitting the equivalent amount of radiation within this spectral band. The measured radiation is emitted primarily in the lower stratosphere and, in this region, is a good indicator of the relative horizontal temperature field and of the general circulation.

On 21 May 1966 (1), the southern polar vortex was well established and located over the South Pole. It was, however, asymmetric. 20 days later (2) the temperature asymmetry was almost reversed and the cold air centre cooled by  $5^{\circ}\text{K}$ . On 11 July (3) the temperature over the South Pole dropped by 3 more degrees. Finally, on 24 July (4) the temperature distribution became symmetric around the Pole. (After Warnecke and McCulloch, 1967)

Reflected solar radiation between 0.2 and 4.0  $\mu$  was mapped with the fifth channel. This instrument was carried on NIMBUS II only.

NIMBUS I produced observations covering almost the entire globe every 24 hours with the AVCS and APT experiments, and every 12 hours with the HRIR experiment. These observations ceased four weeks after launch when the mechanical drive for the paddles carrying the solar-cell power source malfunctioned. Similar AVCS observations were obtained with NIMBUS II from 15 May to 31 August 1966. HRIR observations, stored for each orbit and retransmitted to the primary data acquisition station in Alaska as well as transmitted directly via APT over the whole world, were made from 15 May to 15 November 1966. The MRIR provided global maps of radiation intensities for all five channels from 15 May to 28 July 1966. In each case, observations ceased because the tape recorder associated with each experiment ceased to operate. Day-time cloud pictures from the APT television camera, which was independent of any tape recorder, were transmitted world-wide to about two hundred receivers for almost two years.

The HRIR demonstrated not only that cloud formations can be observed globally at night with a spatial resolution of about 8 km, but also that cloud heights can be inferred from the measured cloud-top temperatures. Thus, at night, the HRIR produced 3-dimensional global cloud maps which were not attainable with television cameras. The 10.5-11.5  $\mu$  channel of the MRIR also produced these cloud-cover and height maps but during day and night and with considerably lesser spatial resolution (50 km). Based on this technology, there will be a high resolution 11  $\mu$  scanning radiometer on ESSA's second generation TIROS Operational Satellite for day and night operational cloud mapping, globally as well as by transmission via the APT system.

A major new approach to the synoptic mapping of large-scale weather patterns was demonstrated by simultaneous analyses of the 10.5-11.5  $\mu$  and the 6.4-6.9  $\mu$  channels of the MRIR (Nordberg et al., 1966). The moisture and cloudiness contrast in the two channels could be interpreted as indications of large-scale vertical motions and of dynamic activity. The course of the jet streams, with rising air on the equatorward side and subsiding air on the poleward side of the core, could be traced especially well.

In cloud-free areas the HRIR mapped temperatures of the Earth's surface with sufficiently great accuracy to permit the tracking of ocean currents (Figure 2).

Analysis of the combined measurements in the 5-30  $\mu$  and 0.2-4  $\mu$  channels and of the 14-16  $\mu$  channels of the NIMBUS II MRIR provided significant new insights into two important atmospheric processes; the global distribution of net radiative energy flux through the upper boundary of the atmosphere (Raschke and Pasternak, 1967) and the morphology of the circulation in the lower stratosphere (Warnecke and McCulloch, 1967). Examples for these analyses are shown in Figures 3 and 4 respectively.

### III. Sounding the Atmosphere with NIMBUS III and IV

Experiments on NIMBUS I and II were devoted exclusively to improving the synoptic mapping of meteorological phenomena or to making atmospheric measurements of general scientific interest. The success of modelling the general circulation of the atmosphere mathematically, which came to fruition recently through the facility of large computers, now placed an entirely different requirement on satellite observations: it called for the global description of the atmospheric mass and wind fields at various height levels. For, if such a description were obtained, it could be used mathematically as the initial state of the atmosphere from which its future state could be computed. Thus, mathematical weather predictions, possibly over periods of two weeks, might become feasible.

Unfortunately, the only applicable parameter which at this time lends itself to measurement from satellites is the temperature variation with height in the troposphere and lower stratosphere. Even that measurement may be seriously compromised by the varying cloud cover. But still, based on existing sensor and spacecraft technology, this is the most promising measurement to be made. Temperature as a function of height in the atmosphere might be inferred from measurements of radiation emitted by a gas such as CO<sub>2</sub>, which is uniformly mixed with air. Measurements must be made spectrally; i.e., at several wavelengths within the absorption (emission) band of the gas. The derivation of temperature is based on the concept that the spectral radiance (which is related to the temperature of the gas) observed by the satellite at various wavelengths corresponds to different height levels, depending on the transparency

of the gas at a given wavelength. This concept is illustrated in Figure 5, where the spectral radiance measured near the edge of the  $\text{CO}_2$  band, indicating a temperature of about  $290^\circ\text{K}$  near wave number  $800\text{ cm}^{-1}$ , corresponds to a temperature near the surface while the temperature of  $230^\circ\text{K}$  at the centre of the absorption band near  $670\text{ cm}^{-1}$ , where  $\text{CO}_2$  is most opaque, corresponds to the maximum height, several kilometres above the tropopause. The temperature reversal at the tropopause is clearly indicated in the spectrum near  $620$  and  $700\text{ cm}^{-1}$ . The atmospheric mass field — i.e., the variation of density with latitude, longitude and height — could be computed from the measured temperature profiles, provided that pressure at a given level, preferably the surface, is known. Surface pressure could be measured by automatic sensors distributed world-wide and transmitting their data to a satellite.

Measurement of wind from satellites is very difficult and has so far been successful only under severe limitations, through inference from cloud observations with the ATS. Wind measurements from lower-altitude satellites might be performed by tracking free-floating balloons globally at various height levels. Eventual operational systems will probably combine both techniques to arrive at a satisfactory description of the wind field.

On the basis of these requirements and assessments, two spectrometer experiments capable of measuring the vertical temperature structure and one experiment capable of relaying measurements from automatic stations and of tracking balloons were selected for flight on NIMBUS III. One spectrometer is a Michelson interferometer called Infra-red Interferometer Spectrometer (IRIS) which operates between  $6$  and  $20\ \mu$  at a relative spectral resolution of 1:200. Included within this spectral interval are the water-vapour absorption band centred at  $6.3\ \mu$ , the  $9.6\ \mu$  ozone band, and the  $15\ \mu$   $\text{CO}_2$  band. Hence, information on atmospheric water vapour and ozone as well as vertical temperature structures should be available from these data. The second spectrometer, the Satellite Infra-red Spectrometer (SIRS), is a modified Fastie-Ebert grating spectrometer. Radiant energy is detected in seven spectral intervals of the  $15\ \mu$   $\text{CO}_2$  band. The spectral intervals are  $5\text{ cm}^{-1}$  wide. The eighth channel senses radiation in the atmospheric window, centred at  $11.1\ \mu$ .

The data relay and balloon tracking experiment, called Interrogation, Recording and Location System (IRLS), consists of a satellite-borne transmitter, receiver and computer which, by communication with a given automatic ground station, can determine the location of the station within about  $2\text{ km}$  and can also interrogate a set of sensors, such as a thermistor, contained in the station.

Four additional experiments have been selected for flight on NIMBUS III. Three of these will continue the mapping observations of NIMBUS I and II: the HRIR, MRIR and the Image Dissector Camera System (IDCS), which is an improved television camera. The fourth, Monitor of Ultra-violet Solar Energy (MUSE), will expand the capability of NIMBUS to perform scientific investigations relevant to meteorology. MUSE will measure solar radiation in five,  $100\text{\AA}$ -wide spectral intervals ranging from  $1200\text{\AA}$  to  $2600\text{\AA}$ . Variation in that radiation might have a strong bearing on the energy input into the stratosphere.

The first launch of NIMBUS III was attempted on 18 May 1968, but failed because of a mal-function in the launch vehicle. A successful launch of a replacement was made in April 1969.

A complement of nine experiments on NIMBUS IV will continue the pursuit of the three major objectives: atmospheric structure measurements for mathematical prediction models, basic scientific investigations, and mapping of horizontal fields, in that order of priority. The emphasis on the first objective is indicated by the fact that four experiments will be capable of temperature soundings and three of the four will also measure vertical distribution of water vapour: the IRIS with its spectral range extended to  $8-40\ \mu$ ; the SIRS with the addition of 6 spectral intervals, mostly in the rotational water-vapour band between  $18$  and  $30\ \mu$ ; and a Filter Wedge Spectrometer (FWS) operating between  $1.2$  and  $6.4\ \mu$ . The other temperature sounder is a Selective Chopper Radiometer (SCR) operating in the  $15\ \mu$   $\text{CO}_2$  band; it is expected to achieve a very high spectral resolution by filtering the radiation through  $\text{CO}_2$  absorption cells. The IRLS experiment will be expanded to be capable of interrogating hundreds of stations instead of the 20 on NIMBUS III. Also, a balloon experiment will be performed to measure the wind field at at least one height level over a large selected region, such as the tropics; on NIMBUS III, only an engineering test of the system, involving less than six balloons over the United States, will be performed.

Scientific investigations will be further expanded with NIMBUS IV. A Backscatter Ultra-violet (BUV) spectrometer will measure the intensity of solar radiation reflected by the atmosphere in 14 intervals, each  $10\text{\AA}$  wide, over the spectral range from 2500 to  $3400\text{\AA}$ . The global vertical distribution of ozone at heights from 15 to 50 km will be derived from these measurements. The MUSE experiment will be continued, and its value will be enhanced by combining it with the BUV measurements.

Measurements of horizontal water-vapour and cloud fields will be greatly improved by a scanning Temperature and Humidity Infra-red Radiometer (THIR) operating in the  $6.3\ \mu$  water-vapour and the  $11\ \mu$  window bands with a spatial resolution of the HRIR. The IDCS will continue to provide television pictures for reference purposes.

It is expected that the experiments on NIMBUS IV, for which early test models exist already, will be flown by 1970.

Plans are now being made for the development of two more NIMBUS spacecraft to be launched after 1971. They might extend the earlier experiments for both vertical soundings of the atmosphere and mapping of horizontal fields into the microwave spectrum. The same principle as in the infra-red holds for sounding and mapping at longer wavelengths, except that microwave emission from clouds is confined essentially to dense water cloud. Thus, vertical temperature soundings in the microwave spectrum will suffer from considerably lesser interference by cirrus and stratus clouds and by haze than in the infra-red. Oxygen, at wavelengths near 0.5 cm, serves as the emitter analogously to the  $15\ \mu$   $\text{CO}_2$  emission. Water vapour can be observed at 1.35 cm and heavy clouds or rainfall could be mapped at wavelengths between 1.5 and 1.8 cm. These spacecraft may also carry experiments to expand scientific investigations, especially, for example, by studying the interface between the ocean surface and the atmosphere and interactions between various atmospheric levels.

#### IV. Outlook

Results from the NIMBUS and ATS experiments will be applied to develop a second generation operational meteorological satellite system in the United States. Also, on the basis of the experience gained from NIMBUS and ATS experiments, satellite observations could be designed specifically to apply to GARP and to the World Weather Watch. The problem is to define the most suitable observations required by these programmes and to conduct the operation cost-effectively. This must be accomplished in the near future through the cooperation of appropriate international organizations. The necessary technology is certainly available. For example, a simple meteorological satellite (simpler than the present ATS) at geosynchronous altitudes could support a regional (tropical) GARP experiment by observing cloud cover continuously and by relaying data from surface and airborne platforms. A more extensive global experiment could be supported by a series of such geosynchronous satellites plus a low-altitude spacecraft in a high inclination orbit, but simpler than NIMBUS, to perform vertical soundings.

#### V. References

- McQuain, R. H. (1967): ATS-I camera experiment successful. Bull. Am. Meteor. Soc., v.48, p.74-79.
- Nordberg, W., McCulloch, A. W., Foshee, L. L. and Bandoen, W. R. (1966): Preliminary results from NIMBUS II. Bull. Amer. Meteor. Soc., v.47, p.857-872
- Raschke, E. Pasternak, M. (1967): The global radiation balance of the Earth-atmosphere system obtained from radiation data of the meteorological satellite NIMBUS II. Space Research VIII, pp. 1033-1043, North-Holland Publishing Co., Amsterdam.
- Warnecke, G., Allison, L. and Foshee, L. L. (1967): Observations of sea-surface temperatures and ocean currents from NIMBUS II. Space Research VIII, pp. 1016-1023, North-Holland Publishing Co., Amsterdam
- Warnecke, G. and McCulloch, A. W. (1967): Stratospheric temperature patterns derived from NIMBUS II measurements. Space Research VIII, pp. 1012-1015, North-Holland Publishing Co., Amsterdam.



Warnecke, G. and Sunderlin, W. S. (1968): The first color picture of the Earth taken from the ATS-III satellite. *Bull. Am. Meteor. Soc.*, v.49, p.75-83.

Weinstein, M. and Suomi, V. E. (1961): Analysis of satellite infra-red radiation measurements on a synoptic scale. *Monthly Weather Rev.*, v.89, #11, Nov 1961.

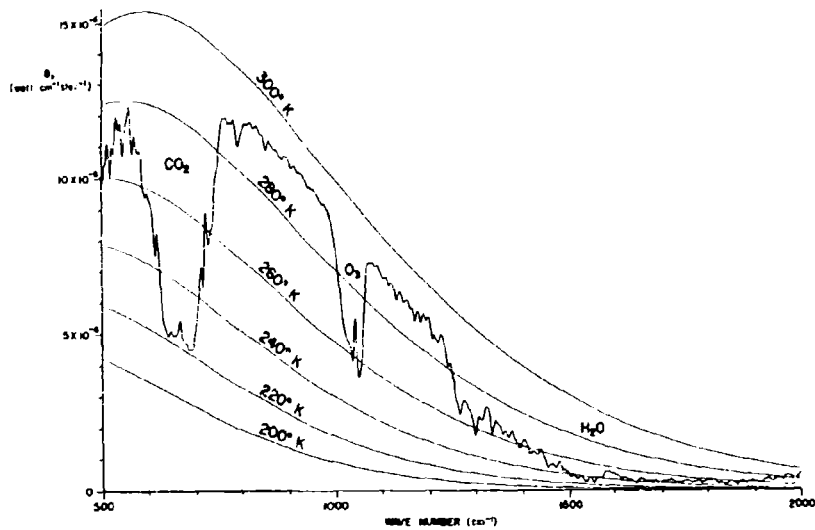

Figure 5. - Spectrum of the atmosphere obtained with an infra-red interferometer spectrometer from a balloon at an altitude of about 31 km over Texas, May 1966. The measurement was provided by R. A. Hanel, Goddard Space Flight Center and L. Chaney, University of Michigan.

NATIONAL DATA BUOY DEVELOPMENT PROJECT  
A STATUS REPORT\*

Captain J. A. Hodgman, US Coast Guard\*\*  
National Data Buoy Development Project  
US Coast Guard Headquarters  
Washington, DC 20591

In 1967 the US Coast Guard was selected by the National Council to undertake the RDT&E necessary to develop the capability to implement National Data Buoy Systems. The development is based upon the composite Federal agencies' requirements, both military and civilian, for marine environmental data to the degree practical.

The development of National Data Buoy Systems is predicated upon a "systems effectiveness concept" focused on the capability output - the product of the total system: data buoys, servicing ships, shore station support, telecommunications and sensors. System planning embraces the "user-producer" dialogue and the Concept Formulation/Engineering Development philosophy of the RDT&E process as a guide. The Preliminary Concept Formulation Summary document provides an outline of initial progress and plans.

The Fiscal Year 1969 program encompassed project management, systems planning and investigations associated with Concept Formulation. The in-house, contractual and cooperative activities are described. These efforts are being used as inputs to formulation of Proposed Technical Approaches (PTA) with contractual assistance as part of a long-range development plan. The systems engineering and management support teams will also contribute towards formulation of the Concept Formulation Plan (CFP), down to the work statement level, and a detailed test and evaluation program.

The development program consists of a three-pronged attack: (1) laboratory and in situ test and evaluation program for sensors, buoys and subsystem components, (2) Pilot Buoy Network development - Concept Formulation and Engineering Development of RDT&E networks, and (3) an exploratory development program - improvements beyond the near-term state-of-the-art for high risk or low performance components and materials. In addition, national requirements for the US Great Lakes, estuaries and Arctic will be investigated.

#### INTRODUCTION

In 1967 the US Coast Guard was selected by the National Council on Marine Resources and Engineering Development to undertake the research, development, test and evaluation (RDT&E) necessary to develop the capability to implement National Data Buoy (NDB) Systems.

Being marine oriented, I am sure you concur in the need for marine environmental data to further improve our scientific knowledge of the atmosphere and the oceans, depict their present state more accurately, and improve predictions of their future state. Data buoys have been shown to be cost effective and have a significant capacity to acquire the volume and quality of data required, among a mix of platforms (1, 2, 3). More recently, other national and international planning activities have stressed the need for a coordinated data collection system utilizing buoys and other appropriate platforms (4-9). Another recent study, the Report of the President's Commission on Marine Science, Engineering and Resources, highlights

\*There was insufficient time on the agenda of Session I for presentation of this status report. However, Captain Hodgman was invited to submit the report for publication in these proceedings. Captain Zettel, USCG, spoke briefly about it in the discussion period of Session IV.

\*\*The opinions and assertions expressed in this paper are those of the author, and do not necessarily represent the views of the Commandant or the Coast Guard at large.

a "pilot buoy network" as a National Project meriting "consideration for early implementation" (10). It identifies the Coast Guard as the agency to develop buoy technology, develop and evaluate systems requirements, and take the necessary technical and analytical steps leading to a national capability to deploy NDB Systems. Rather than generalizing further, I should like to devote the remainder of this paper to summarizing the NDB Development Project's planned program and first year of progress. I emphasize that we are in the conceptual stage of the program and are working with other Federal agencies, the scientific community, inter-agency groups, users and the Congress to develop a course of action that will meet national needs at the least cost.

#### PLANNED PROGRAM

A fundamental development goal of the NDB Development Project is to deploy pilot buoy networks by 1975. The pilot buoy networks will:

- . . . be deployed along the continental shelf and deep oceans adjacent to the United States.
- . . . be used to assess the reliability and effectiveness of the prototype development.
- . . . provide data that will permit a better scientific understanding of the marine environment.
- . . . demonstrate the economic, military, scientific and social benefits that may be derived from operational NDB Systems.

The development program is based generally on a three-pronged plan of attack (Figure 1):

(1) First, a thorough assessment of buoy and sensor technology. Concurrent laboratory and in situ testing and evaluation of sensors and support hardware will be conducted. Platforms in the oceans, together with mobile communications equipment will be used for in situ testing of components such as sensors, moorings, telemetry, and buoy platforms. This effort will provide performance information for correlation with laboratory test results.

(2) Second, a program of applied research and exploratory investigations. This phase will be directed at achieving improvements beyond the near-term state-of-the-art for high risk or low performance components and materials. Investigations will cover items such as sensors with a minimum number of moving parts, improved protective coatings to prevent marine fouling, new materials for mooring cables, and improved power supplies. The requirements for observations in the Great Lakes, estuarial, and polar regions will also be studied. Development of biological and chemical sensors which would expand buoy system capability may also be undertaken.

(3) Finally, Concept Formulation and Engineering Development of pilot buoy networks. The objective of Concept Formulation is to provide the technical and economic bases for a decision to initiate Engineering Development. During Concept Formulation, cost, performance, and schedule estimates of system alternatives needed for adequate tradeoff and risk analyses will be undertaken. Design factors of major components such as sensors, moorings, power supplies, telemetry, buoy platforms, servicing ships and shore station will be investigated along with operational and maintenance concepts. Mission and environmental variability analyses and refined requirements will be integrated with the technical development to yield realistic performance characteristics, and the technical feasibility of the systems proposed will be demonstrated. The activities of Concept Formulation will result in firm requirements and baseline characteristics for data buoy systems with competitive cost-effectiveness values. During Engineering Development, design specifications will be developed and pilot buoy networks designed and manufactured.

#### YEAR OF PLANS AND PROGRESS

The Project has now been in existence over a year. For the first few months, the Project Office was supported by available reprogrammed funds within the Coast Guard. The primary activities centered around organization, staffing, development of system planning, programming and budgeting, and continuation of follow-on studies to amplify the initial Feasibility Study (1).

As you remember, the general Federal budget reduction in Fiscal Year 1969 precluded a full-scale start of the development program. Funds in the amount of \$580,000 were reprogrammed from within the Coast Guard Research and Development appropriation to sustain the project after Congress deferred funding of the Project without prejudice. With these resources we were able to perform selected activities incident to Concept Formulation in Fiscal Year 1969. Needless to say, the budgetary situation for Fiscal Year 1970 is still uncertain. The portion of the planned program the Project will be able to execute the coming year will be determined by the present budgetary decisions and subsequent congressional action.

Despite the relatively low level project funding to date, however, significant steps have been taken this past year. They encompass systems planning and investigations through in-house, contractual and cooperative efforts. I will briefly touch on twelve of these activities.

(1) System planning embracing the "user-producer" dialogue of the RDT&E process has been initiated. The Preliminary Concept Formulation Summary document (11) issued by the Project Office outlines the factors involved in the development task, an approach to the problem and general plans for Concept Formulation. It also promulgated a Tentative Specific Operational Requirement (TSOR).

(2) Under contract to the Project Office, the Travelers Research Corporation has completed additional work consisting of:

- . . . Refined national marine environmental data requirements (12).
- . . . Computer programs for simulation and cost models (13).
- . . . Simulation model of the operations involved in the deployment and maintenance of buoy networks (14).
- . . . Investigations of the natural variability of pertinent marine environmental parameters and the impact on data use and performance characteristics (15).
- . . . Cost-effectiveness sensitivity studies of alternative data buoy systems, alone and in various combinations with other platforms (13).

(3) The opportunity was used to add a real-time satellite relay capability to one buoy being deployed as part of the Joint Scripps Institution of Oceanograph-Office of Naval Research (ONR)-Coast Guard North Pacific experiment. One of ONR's large discus buoys was fitted with VHF communications equipment to permit the relay of measured data via the NASA ATS-1 synchronous satellite. This added capability will provide side-by-side comparison of data transmitted directly by HF with data transmitted by satellite link communications.

(4) In sensor development, the efforts of the Project Office have focused on a survey of oceanographic and meteorological sensor technology. Similar review of other system components is underway. In cooperation with other Coast Guard activities interested in oceanographic sensor development, and in coordination with the National Oceanographic Instrumentation Center and the National Oceanographic Data Center, the Project is currently reviewing proposals for a study to:

- . . . Assess the state-of-the-art of oceanographic sensors.
- . . . Formulate test and calibration standards and procedures for Coast Guard sensors.
- . . . Establish standard specifications for hardware.

(5) A limited mooring test and evaluation program is in the planning stage; tests in the oceans will commence in the fall of 1969.

(6) Quantification of the potential benefits to users which will be achieved from improved marine environmental information is recognized as a difficult task. Not only must one determine and relate the necessary increased volume and quality of data, with appropriate spatial coverage, to improved levels of environmental prediction, but a second step is also

necessary that of relating the net worth of the improved environmental predictions and data to benefits to the users. And finally, the appropriate mix of sensors and platforms for the optimum environmental system must be determined. Much of this work is beyond the scope of the Project Office. However, initial efforts impinging upon NDB Systems development have been undertaken. For example, in-house efforts have resulted in survey and documentation, in a preliminary fashion, of the extensive need for and use of improved environmental information by the construction and offshore oil and gas industries and by marine military (naval) activities. Similar efforts are also being directed toward the fisheries industry. In addition, the Project Office has recently contracted with the Resource Management Corporation of Bethesda, Maryland, to assess the benefits to transportation (air, land and sea) that will accrue from improved environmental prediction. Similar in-depth quantitative studies are needed for all major functional users of improved environmental information.

(7) Six high-frequency radio bands have been set aside for oceanographic use on an international basis. The Project Office is funding and coordinating a study effort by the Environmental Science Services Administration's (ESSA) Institute of Telecommunication Sciences to recommend the optimum utilization and allocation of this limited resource.

(8) Earlier this month the Project Office sponsored a Scientific Advisory Meeting at the Coast Guard Academy, New London, Connecticut. Attendance included more than 30 leading scientists working in the field of the marine environment. The experience and guidance of this knowledgeable group will provide an important contribution to the development and use of NDB Systems. Their interest in integrating scientific experiments into pilot buoy networks and operational systems is particularly noteworthy.

(9) Ship support for the major Federal government data buoy programs has provided valuable experience and information on buoy handling and servicing problems.

(10) As in any other major development effort, extensive coordination with potential users, the scientific community and industry is considered necessary and is being effected on a continuing basis. In addition, the Project Office is working with other Federal agencies in developing United States' positions for implementing "ocean stations" for data acquisition, and in international sharing of the data and resulting products. These activities are coordinated internationally through the Integrated Global Ocean Station System (IGOSS) Working Group of the Intergovernmental Oceanographic Commission (IOC) and the World Weather (Watch) Program (WWV) of the World Meteorological Organization (WMO).

(11) In the areas of alternative technical approaches and cost-effectiveness analyses, two major in-house studies have been undertaken. The first contains substantial elements of a Proposed Technical Approach (PTA) for data buoy network development in the deep ocean and coastal areas, considering only data buoys with an optimum capability. The second study compared alternate levels (vertical) of sensing capability with costs associated with achieving the postulated capability. The latter results indicate that systems incorporating advanced technology are significantly more cost effective than systems based on existing capability. The extent of systems implementation should not alter this relationship. However, there does not appear to be a clear cut differentiation among the various levels of capability based on cost-effectiveness alone. Therefore, systems planning should incorporate flexibility during the early development phases. These study efforts will be used, in conjunction with contractual support, to develop a Proposed Technical Approach (PTA).

(12) As a result of competitive selection, the Project Office has contracted with the Systems Management Division, Sperry Rand Inc., for system engineering and project management support. Sperry Rand is now assisting the Project Office in documenting the Proposed Technical Approaches (PTA) as part of a long-range development plan. The work will include, in more detail, a Concept Formulation Plan (CFP) down to the work statement level and a test and evaluation program.

#### FUTURE PLANS

The scope of future plans will depend upon the level of funding authorized. It is anticipated that the Fiscal Year 1970 program will continue mission and systems engineering analyses, initiate a program of sensor tests and development, and investigate and test design factors for buoy hulls and moorings. Additional important work, however, needs to be accomplished. System performance requirements must be defined more accurately to permit

improved system engineering analyses, and reliability and maintenance concepts must be investigated in detail as part of the systems engineering effort. The initiation of sensor development and a testing program are critical first steps in pilot buoy network development. Buoy hull and mooring design factors are needed now due to the extensive interaction of these two components with other segments of the system. The efforts of Fiscal Year 1969 will form the basis for selection of the critical activities to be carried out in 1970.

CONCLUSION

The development of NDB Systems is difficult, time consuming and costly, even using the experience of related programs. Yet all initial analyses indicate that the benefits which should be derived from improved understanding and prediction of the global environment will exceed costs by a large margin. Near real-time synoptic information from the ocean areas of the world is essential to any improved understanding and prediction of the environment, and buoys are a cost-effective approach to obtaining that information. For this reason the Coast Guard project to develop the capability to implement national buoy networks is an important part of the United States' marine sciences program. The demonstration of the ability to operate limited networks in the oceans, to solve scientific problems and derive economic, military and social benefits from them, is a major development goal. I anticipate buoys of more than one class or capability. It is probable that following the development program operational systems will be deployed in oceans adjacent to the United States where national benefits will be greatest and in nationally sponsored environmental experiments. It is clear, however, that each step in development and implementation must be justified, and the potential benefits defined, to assure that limited national resources are effectively utilized.

The development program requires coordination with similar programs involving data communications, processing and archiving systems, as well as compatibility with international systems. Through such coordination and a systematic approach to development, the Coast Guard will assure that NDB Systems will be developed that are responsive to the composite national requirements.

**FIGURE 1 NATIONAL DATA BUOY DEVELOPMENT PROGRAM**

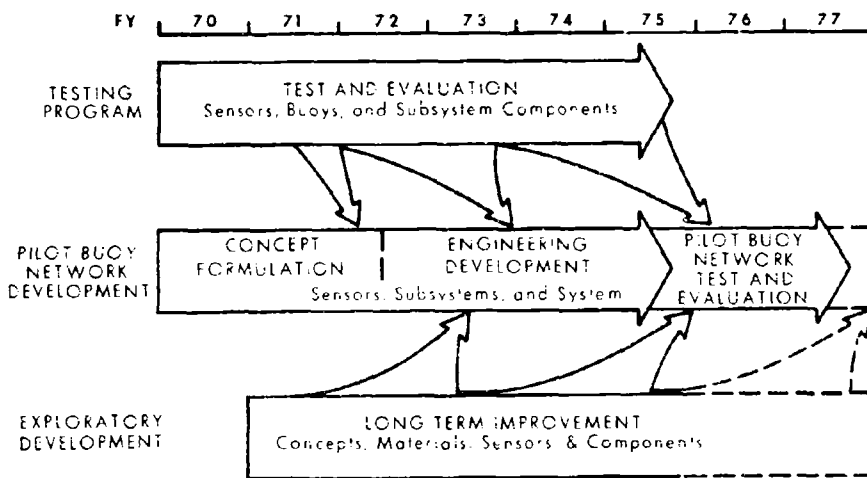

#### REFERENCES

1. Aubert, E. J., "A Summary of the Study of the Feasibility of National Data Buoy Systems", TRC Report 7485-286, USCG Contract TCG-16790-A, The Travelers Research Center, February 1968 (AD 665314).
2. Jenkins, C. F., E. J. Aubert, W. R. B. Caruth, L. H. Clem and R. G. Walden, "A Cost Effectiveness Evaluation of Buoy and Non-Buoy Systems to Meet the National Requirements for Marine Data", TRC Report 7485-274, USCG Contract TCG-16790-A, The Travelers Research Center, September 1967 (AD 664619).
3. Jenkins, C. F., A. Thomasell, Jr., D. B. Spiegler and G. M. Northrop, "Cost Effectiveness Sensitivity of National Data Buoy Systems: An Essay", TRC Report 7493-336, USCG Contract DOT-CG-82504-A, The Travelers Research Center, December 1968 (AD 682516).
4. "Federal Plan for Marine Meteorological Services" (MARMET), Office of the Federal Coordinator for Meteorological Services and Supporting Research, US Department of Commerce/Environmental Science Services Administration, Report OFCM 68-4, May 1968.
5. "Federal Planning Guide for Marine Environmental Prediction (MAREP)", Ad Hoc Task Group, Committee on Oceanographic Exploration and Environmental Services, National Council on Marine Resources and Engineering Development, January 1969.
6. "World Weather (Watch) Program Plan for Fiscal Year 1970" (WWW), President's Report to Congress, March 1969.
7. "Integrated Global Ocean Station System (IGOSS)", The Plan and Implementation Programme-Phase I, United Nations Educational Scientific and Cultural Organization, Intergovernmental Oceanographic Commission, Working Paper (Unpublished), January 1969.
8. "Summary Report, Working Committee for an Integrated Global Ocean Station System (IGOSS)", 2nd Meeting, World Meteorological Organization, Geneva, 24 February 1969, United Nations Educational Scientific and Cultural Organization, Intergovernmental Oceanographic Commission (Unpublished), March 1969.
9. "An Oceanic Quest", The International Decade of Ocean Exploration (IDOE), Joint Study by the National Academy of Sciences and National Academy of Engineering for the National Council on Marine Resources and Engineering Development, February 1969.
10. "Our Nation and the Sea", A Plan for National Action, Report of the Commission on Marine Science, Engineering and Resources, January 1969.
11. "Preliminary Concept Formulation Summary for National Data Buoy Systems", National Data Buoy Development Project, US Coast Guard Headquarters, Wash DC, October 1968 (AD 678696).
12. Clem, L. H. and G. M. Northrop, "Applicability of National Data Buoy Systems to Refined National Requirements for Marine Meteorological and Oceanographic Data", Vol. I & II, TRC Reports 7493-332a & b, USCG Contract DOT-CG-82504-A, The Travelers Research Center, October 1968 (AD 682512 & AD 682513).
13. Davis, E. L., B. J. Erickson and E. R. Sweeten, "Computer Programs for National Data Buoy Systems Simulation and Cost Models", TRC Report 7493-333, USCG Contract DOT-CG-82504-A, The Travelers Research Center, October 1968 (AD 682514).

14. Northrop, G. M., "An Analysis of Cruise Strategies and Costs for Deployment of National Data Buoy Systems", TRC Report 7493-337, USCG Contract DOT-CG-82504-A, The Travelers Research Center, November 1968 (AD 682517).
15. Jacobs, C. A. and J. P. Pandolfo, "Characteristics of National Data Buoy Systems: Their Impact on Data Use and Measurement of Natural Phenomena", TRC Report 7493-334, USCG Contract DOT-CG-82504-A, The Travelers Research Center, December 1968 (AD 682515).



USAF AEROSPACE ENVIRONMENTAL  
DATA COMMUNICATIONS  
IN THE '70s

Robert W. Fanning, Major, USAF  
DCS/Operations, Communications Division  
Hq Air Weather Service  
Scott AFB, Illinois

The function of USAF Aerospace Environmental Data Communications is to build a comprehensive world-wide environmental data base at one place — AFGWC, and second to provide USAF supported functions tailored portions of that data base which they require. The envisioned concept of building and applying a central data base is viewed as valid throughout the foreseeable future.

To build the data base, USAF taps many data sources. By far, the bulk of environmental data are obtained from other than U. S. military sources. The simplest of these is a reletype drop from such services as the U.S. Weather Bureau. However, data sources employed range in complexity from manual intercept of CW Morse broadcasts to connection with satellite data wide-band telemetering systems.

Environmental information is disseminated in many ways. Data are provided to weather stations in the time-honored teletype collective and facsimile map forms. Relatively new on the scene, however, is provision of environmental information, tailored to operational requirements, directly from a meteorological computer to a command and control or other operational system on a query/response basis.

The communications equipment and techniques employed are an amalgamation of manual, semi-automated, and fully automated facilities. The need for such a broad range of communications capabilities is seen as a continuing requirement as newly emerging data sources enter the world meteorological community on a low technical and economic level, while the now very sophisticated systems continue to push the state-of-the-art.

## I. Introduction

The Air Weather Service (AWS) goal is to provide our USAF and U. S. Army customers with environmental information tailored exactly to their requirements. AWS is pursuing centralization as the means to achieve that kind of environmental support capability. Our centralization concept envisions a comprehensive world-wide data base at the Air Force Global Weather Central (AFGWC), Offutt AFB NB: a data base extending from about 72 hrs in the past to some 48 hrs in the future. AWS support is increasingly based upon providing from this data base tailored information for places, times, and altitudes required to satisfy our customers.

## II. Production Of The Data Base

To acquire a world-wide environmental data base, the USAF taps many sources. Conventional weather data are collected from U. S. military bases on USAF weather teletype circuits throughout the world, and from the familiar FAA and USWB domestic weather teletype services. Similarly, overseas we are connected to foreign national meteorological teletype systems such as the British, German, and Japanese. We are also planning a direct interface with the World Meteorological Organization World Weather Watch hub at Tokyo, Japan.

Radio Weather Intercept. A great deal of the world's observational data is not available through conventional teletype sources. To get the dense data coverage we require in a timely fashion, the USAF has in operation a radio weather intercept program. The Air Force Communications Service operates six intercept sites for the USAF. These six sites are located at Fuchu, Japan; Croughton, England; Ie Shima, Okinawa; San Pablo, Spain; Clark AB, R.P.; and Incirlik, Turkey. Now in the programming stages is an intercept capability for Howard AB, Canal Zone, to acquire South American data.

In addition, the U. S. Navy augments the USAF intercept capability with their facilities at Sangley Pt., R.P; Northwest Cape, Australia; Rota, Spain; and Asmara Ethiopia.

Even with this multitude of sources, the world data base is far from complete, especially for the Southern Hemisphere.

Automated Weather Network (AWN). Ask any weatherman, he'll tell you it takes too long to collect data. 100-WPM teletype is too slow - let alone 25-WPM CW Morse Code radio intercept.

To speed data delivery and improve ultimate support to the USAF, the AWN was conceived in 1964 and implemented in 1965. The purpose: to cut delays between the source collection points and the AFGWC. The AWN consists of UNIVAC 418 computers and peripherals at Fuchu, Japan; High Wycombe, England; Tinker AFB, Oklahoma; and Offutt AFB, Nebraska, connected by data speed circuits. The Tinker site will be transferred to Carswell AFB, TX in October 1969, and a new site will become operational at Clark AB, R.P. in December. Once the data enter the AWN computers, they are delivered to AFGWC within about 3 minutes. This is a far cry from the old paper tape and radio teletype system. While the prime purpose of the AWN is to deliver data to AFGWC, the computer capability of the AWN has been exploited to control our USAF teletype collection and dissemination systems. The return side of the full duplex AWN data circuits is used to deliver AFGWC prognostic products to high speed printers at Fuchu and High Wycombe. These products support the weather centrals at those sites and their respective facsimile schedules. We are exploring ways to move digitized graphics products through the AWN.

How well has this system performed? In the mid '50s, it took 6 hrs to gather enough data to make a usable global analysis and prognosis. This resulted in USAF customer support being based on 30-hr prognoses. By the mid '60s, collection time was down to about 4 hours, and we were working with a mission midpoint of something over 30 hours. With the AWN, we are now delivering the data to AFGWC in time to permit data cutoff at 3 hrs and 20 min after synoptic observation times, with the result that our mission support today is essentially based on a 24-hr prognosis. Not all this speed-up is due to faster data collection. A good deal of the speedup has been accomplished in the data processing at AFGWC, some by better coordinated support procedures, and some is due to improved product dissemination techniques.

The Collection Task. We have seen how we gain access to a lot of data in widely scattered places; how do we get it to AFGWC and our other users who need it? The teletype circuits, and radio intercept data converted to teletype form, are fed into computers of the Automated Weather Network (AWN). The AWN computers assimilate, sort, edit, compile into messages and distribute the data. Garbage and duplicates are eliminated. All unique data are sent to AFGWC, and selected portions of the data are distributed in-theater or conventional teletype circuits. Base weather stations still need observations and forecasts for day-to-day support. All the data which flows through the AWN is preserved on magnetic tape and eventually finds its way to the archives at Asheville NC.

Satellite data are acquired at AFGWC from the national satellite data system. Soon, Vela satellite data (non-meteorological environmental data) will begin to flow from Sunnyvale CA directly into AFGWC. The Navy's Fleet Numerical Weather Central (FNWC) at Monterey CA is connected to the AWN; AWN data flow to Monterey and ship reports available to Monterey from the Naval Environmental Data Network are passed to AFGWC via the AWN. A direct data link between Monterey and Offutt is planned in the near future to permit interexchange of classified information. There is also a data link between the AWN and the ESSA National Meteorological Center at Suitland MD. Another new AWN site is being planned for Sembach, Germany, to replace outmoded manual weather relay centers at Torrejon, Spain; and Ramstein, Germany. Finally, just in the planning stage, is an AFGWC automated interface with our Environmental Technical Applications Center, to gain near real-time access to climatological data for our customers' planning purposes.

### III. Future Plans

What then does the future hold? First, we think we are on the right track by centralizing and automating our capabilities and in operating from the single data base concept. For direct computer-to-computer support, we can only go as fast as our supported commands' systems will allow. On the other hand, to acquire data from meteorological agencies which are just entering the world community on a low economic level, we must retain a capability to communicate in a relatively primitive mode; for example, the CW Morse radio intercept. A few firm advances in our communication systems are becoming clear, however.

Digital Graphics. The AWS, like other meteorological services, has for many years used analog facsimile to send maps and charts from central facilities to using locations. Within the next few years, we plan to convert from our present analog facsimile to a new digital graphics system.

#### Proposed USAF Digital Graphics Equipment (Artist's Conception)

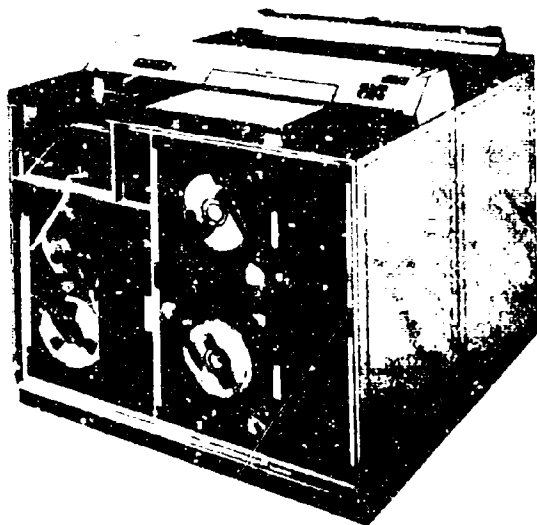

Fig 1. Transmitter, AN/GMT-38( )

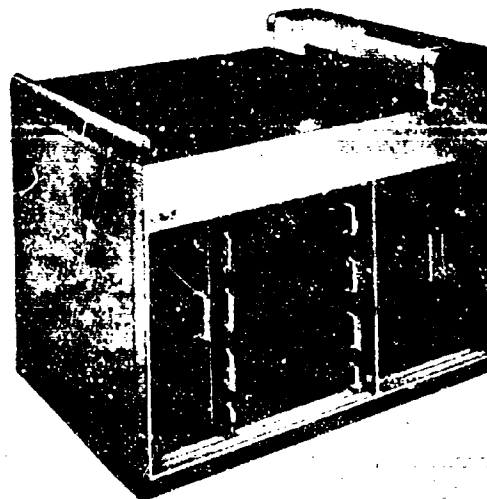

Fig 2. Recorder, AN/GMH-54( )

Fig 1 is an artist's conception of the digital graphics transmitter. For ease in operation, the tape drives will be located in an adjacent stand-up cabinet rather than in the transmitter, as shown. This device will transmit either from page copy (the table top is a flat-bed scanner) or from properly formatted computer tapes. A copy of each transmission is stored by use of a quarter inch magnetic tape canister, which can be retained for retransmission purposes. Whether transmission is from page copy or computer magnetic tape, the transmitter performs data compression with a small internal computer through a compaction algorithm. The compressed information is retained in the magnetic tape canister.

Fig 2 is an artist's conception of the recorder - reproducer. Transmission speed-up is accomplished in two ways—first, by the data compression technique and second, by special modems which are internal to the transmitter and recorder. The recording technique uses an electrostatic medium which is 18" wide, and employs the familiar ink-toner. Copy will be available for use within about 15 seconds after the end of a transmission. By use of up to 100 key signals sent by the transmitter, it is possible for the recorder to automatically record or reject particular products.

We expect to see the first production models in about a year, and to have some circuits converted by 1972.

Data Links. There will soon be some new data speed connections to AFGWC. One is with the satellite control center at Sunnyvale CA which I mentioned earlier. It is for satellite data acquisition using CDC 160A computers at Sunnyvale which will talk directly to the computers at AFGWC.

The Tactical Air Command forecast center at Langley AFB VA will use a UNIVAC DCT-2000 to acquire needed data from AFGWC. It will be on-line to the AFGWC UNIVAC 1108 system through a 2400 baud line. Basically, it consists of a high-speed printer and a punched card send capability for use in requesting information from AFGWC. It will not provide for direct input to the TAC C&C system, but is a step in the right direction.

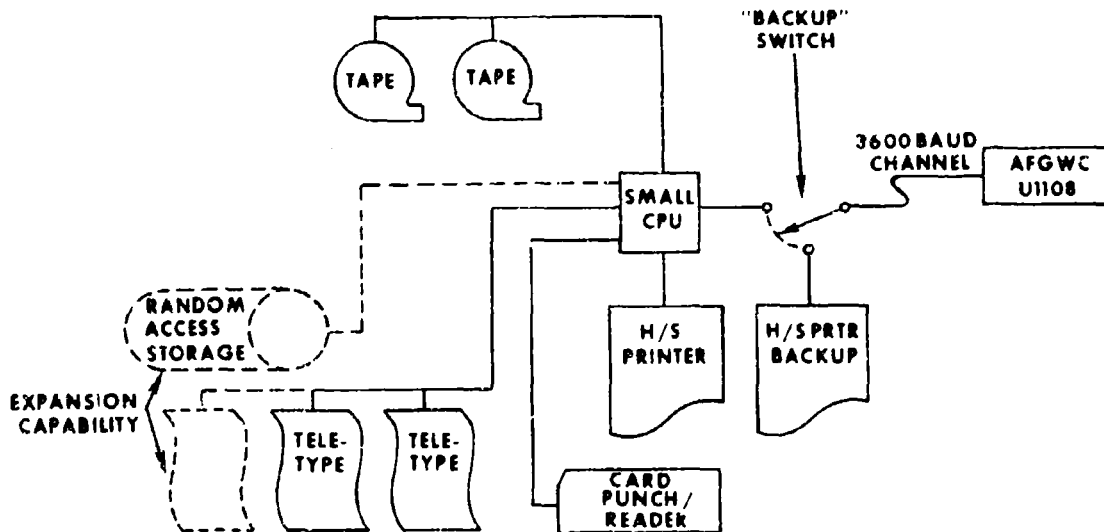

Fig 3. Proposed NORAD Forecast Center Data Terminal

In support of North American Air Defense Command (NORAD) and our solar forecast facility at Colorado Springs CO, we plan a small data terminal of roughly the configuration shown in Fig 3. Data will flow from AFGWC through a small computer at NORAD. Some data will be written to magnetic tape for direct ingestion into NORAD C&C computers. Other data will be routed to high or low speed printers in support of the solar forecast unit and other NORAD Forecast Center functions. In addition, a send capability will permit that center to request special data from AFGWC, and to transmit solar products to AFGWC for further distribution via the AWN or other communications facilities.

Satellite Communications. We are looking more and more to satellite communications. We anticipate that the AWN data channel from Carswell to Clark will be via satellite. Moreover, we envision the satellite as a potentially powerful means of communicating with field forces, such as in Vietnam. Such transmissions could be immediately available to locations in widely separated places. Another application of satellite communications is in weather reconnaissance. There have always been problems in moving weather data from reconnaissance aircraft through the aeronautical communications system to weather users. We plan to implement a limited satellite communication system for our weather reconnaissance aircraft, perhaps as early as winter 1970. This will allow the reconnaissance aircraft to transmit data more or less directly to our weather data processing centers. Hopefully, this will enable us to integrate weather reconnaissance data collection more directly into our data system.

#### V. Conclusion

USAF Aerospace Environmental Communications are an integral part of the AWS total data-handling system. We are looking toward the time when the capabilities of this integrated, master data base system can be fully exploited. The current system is capable of multiplicity of tasks which hasten data acquisition and distribution, archiving, transmission, updating, processing, and delivery of tailored environmental products. The end result must be a balanced system which is capable of interfacing with very primitive data sources on the one hand, and of responding to highly demanding, sophisticated electronic C&C systems on the other. Our challenge is to maintain a dynamic, reliable and survivable system capable of providing timely, accurate, and comprehensive environmental support.

## AFGWC METEOROLOGICAL DISPLAY TECHNIQUES

Charles W. Cook, Lt Col, USAF  
Air Force Global Weather Central

The Air Force Global Weather Central (AFGWC) will provide Military Command Control Systems with tailored information on a real time basis in the 1969 - 1974 time period. A dynamic data base, consisting of all environmental knowledge available to the total Air Weather Service, will provide the source from which efficient application is possible. By prearrangement or upon receipt of a specific requirement, germane portions of the data base will be selected, tailored to operational needs, formatted for display, addressed and transmitted to the customer. Atmospheric data will include observations, terminal forecasts, area forecasts of "sensible" weather and fields of continuous parameters. The latter two will describe macro and meso-scale features. Macro-scale will be available on a global basis at discrete intervals from 5,000 to 100,000 feet and at time intervals from 0 to 72 hours for the distinct Northern Hemisphere, Tropics and Southern Hemisphere entities. Meso-scale will be available for limited areas (window concept) which are additive to and superimposed upon the macro information. Any part of this data base will be available through the Selective Display Model which will plot, contour and list any combination of data for printer output devices. Satellite cloud data will be displayed in orbital mosaics in 16 shades of grey with overlaid graticule by use of the Data Formatter and Display equipment. This system converts the analog data to raw digital data for refinement in the UNIVAC 1108 computer and subsequently displays the refined data on photographic paper. Development is underway to direct drive the weather displays on the automated display equipment of the SAC Automated Command Control System (SACCS) in the command posts at Headquarters SAC and the three numbered air forces. Printer and projected multi-color wall screen displays will provide weather information in plotted, contoured and tabular form. Plans for the future include use of CRT equipment for input of mission information and modifying output. A zoom capability to enlarge areas of concern makes the CRT a most efficient device to change or correct output.

### I. Introduction

1. AFGWC Task. In the early 1970's the Air Force Global Weather Central (AFGWC) will achieve the capability to provide Military Command Control Systems with extensive tailored information on a real time basis. To attain this goal two basic needs are paramount. There must be a dynamic data base available, which to the utmost degree practical at any given moment in Air Weather Service (AWS) evolution will consist of all environmental knowledge available; and there must be a means to efficiently apply this data base.
2. Communications. The key in obtaining data and transmitting tailored products to the customer is communications. The Automatic Weather Network (AWN), Advanced Vidicon Camera Subsystem (AVCS) data link with the National Environmental Satellite Center (NFSC), and high speed link between the AFGWC and the SAC Automated Command Control System (SACCS) are just some of the improved communications to support the AFGWC mission.
3. Computer System. The AFGWC computer system has been upgraded from two (2) IBM 7094's to four (4) UNIVAC 1108's with a total of over 300 million words of storage capacity available on drums. A software means to efficiently operate the four computers as a Real Time Operating System (RTOS) has been developed. All programming has been done with Air Force

personnel. The UNIVAC provided Executive System is the only non-AFGWC software.

4. Numerical Models. More sophisticated numerical models are under development to improve the macro and meso-scale forecast capabilities. For example, techniques to forecast CAT on a hemispheric basis, three dimensional analysis and forecast cloud models for global coverage, boundary layer model for detailed structure of the lower troposphere (surface to 1600 meters), and the Shuman Primitive Equation model as modified by AWS for the UNIVAC 1108. New methods to monitor and update numerical products are being developed. Upper air data will, immediately upon receipt and validation, be compared with the data base, deviations computed and analyzed, and new analyses and prognoses computed when major forecast errors appear. This uses all data, including AIREPS, regardless of observation time.

## II. Data Base

1. Content. The AFGWC data base will consist of space environmental data and atmospheric data. Atmospheric data must include observations, terminal forecasts, area forecasts of "sensible" weather and fields of continuous parameters. The latter two must describe macro and meso-scale features of the atmosphere.

2. Resolution. The macro-scale grid uses a distance of about 200 nautical miles in mid-latitudes (standard numerical coarse mesh grid used by NMC, FMWC and AFGWC); whereas, meso-scale is any finer mesh grid larger than micro-scale. Vertical resolution in the macro-scale is defined to be the levels or layers described by standard pressure levels. The vertical resolution in the meso-scale varies depending on the model. The boundary layer model uses 7 layers between the surface and 1600 meters.

3. Coverage. Unique grids will be used to describe the various interest areas of the globe until a truly integrated global grid is perfected for operational use.

a. Macro-Scale. Macro-scale coverage will be provided on a global basis at discrete intervals from 5,000 to 100,000 feet and at time intervals from 0 to 72 hours. It will consist of the Northern Hemisphere, Tropics and Southern Hemisphere as distinct entities.

b. Meso-Scale. Treatment of the meso-scale features on a standard approaching current technology is expensive in development costs, computer utilization and human resources. In recognition of the costs inherent in global description of meso-scale features and in the realities of varying data densities, the meso capability will be provided only for limited areas (window concept) which are additive to and superimposed upon the macro information. For example, macro area programs must precede and provide boundaries to a meso-window. With exception of certain parameters requiring extensive treatment on a global basis, AFGWC support will be provided by the routine preparation of four distinct windows - United States, Europe, Asia and Southeast Asia. The capability will exist to introduce additional meso windows in support of contingencies.

## III. Display Techniques

1. Concept. To meet the current operational needs for rapid display of data in varying formats and large quantities for both internal and external use, various display techniques to use printer, CRT, photographic, projector and line drawing equipment are in use or under development. Current technology (and economics) dictated the use of printers as the prime display device for the early 1970's. At the present, printers are usually the fastest form of output and current communication systems will handle text messages. CRT's are considered to be a special type of printer device. An associated group of AFGWC programs collectively called the Selective Display Model (SDM) has been developed to

plot, contour and list any combination of data for printer output. Special data formatting and photographic equipment has been installed and AFGWC software developed, to rapidly display rectified satellite cloud data on transparencies or photographic paper at several scales and map projections for visual viewing and interpretation. In the SAC Automated Command Control System (SACCS) displays can be dynamically generated and automatically displayed on printers or projected on wall screen in multi-color. The means to direct drive this equipment and provide the required weather displays from the AFGWC data base, via a high speed data link is under development. Still in use, but slow by present standards, is a Benson Lehner Electroplotter. The advantage of multi-color contours is offset by the slowness of the line drawing mechanism. It fulfills a definite need but cannot be used for prompt operational output of many contoured displays. Standard facsimile map displays are provided 85 distant Department of Defense customers using the automated Facsimile Group Converter developed by United Aircraft Corporation in 1963. This permits transmission of grid point data, geography and contours directly on 3KC lines from magnetic tape. This will be replaced by the new AWS digital facsimile system in the early 1970's.

2. Selective Display Model. The Selective Display Model (SDM) is a group of inter-related programs which can plot, contour and list many different types of data (in various formats), on several types of printers. The SDM works in conjunction with the AFGWC Real Time Operating System (RTOS) and the UNIVAC EXEC VIII on each 1108. Requests for displays are received by the RTOS which then activates the SDM. The SDM decodes the request and calls for the subprograms needed to format the data and produce the requested output. Programs which interface routinely with the RTOS are used to identify and forward the request, retrieve the data from the AFGWC data base and transmit the output.

a. Display Flexibility. In order to provide the flexibility in the displays that will be provided, there are many options which may be specified on the request. Some of the options (more than 100) may be used by the requestor to control the display while others will be used by AFGWC to define special products to meet external transmission requirements. The system would be unworkable if all options had to be specified each time, consequently, standard values are used unless specific values are input on the request.

(1) Area. Any horizontal map area may be specified which is a rectangular section of a polar stereographic or mercator projection. The area is identified by the latitude-longitude of any three corners of the rectangle or by the name of a predefined area. Areas may also be defined in terms of one of the AFGWC grid systems, AFGWC meteorological data regions or WMO blocks.

(2) Scale and True Latitude. Any scale and true latitude may be given. The combination of area, scale and true latitude define the size of the output map. There is no practical limit on this size, but for protective purposes a limit of approximately 25 square feet has been set.

(3) Vertical Extent and Scale. The normal extent of vertical maps is 1050 mbs to 10 mbs. By specifying the extent in either height units (feet or meters) or millibars, the base and top of the map may be set to any altitude. The vertical scale may be specified in log pressure or height.

(4) Display Formats. There are many output formats available to the user. The three different kinds of output, horizontal maps, vertical maps and tabular listings control both the formats within each category and the data selection.

(a) Horizontal Maps. There are four formats associated with horizontal maps --grid, plot, contour and background. Grid causes data from the computer prepared data fields to be plotted at grid point locations. Plot is similar to grid except that station



observations are plotted at the station location. Contour puts isolines of data from the prepared fields on the map. Background can put latitude-longitude lines, geographical boundaries, political boundaries and/or topography on the map.

(b) Vertical Maps. There are four formats associated with vertical maps -- Skew-T, V-grid, X-grid, and X-section. Skew-T is used to display station raob/wind data in the vertical. The data may be presented as a vertical plot or a combination of the two. V-grid will produce the same type of display as Skew-T, but the data will be retrieved from the gridded data base. X-section is used to produce a vertical plot of observational data along some path. This format may be used to produce flight cross-sections. X-grid is the same as X-section except that gridded data will be used instead of station data.

(c) Tabular Listings. Tabular listings of station data may be obtained. This is intended to be used to list a few stations, with most of the observational data, for those operations in which maps are not suitable.

(5) Data Selection. A series of the options are used for data selection. The time option can specify such things as, time period for which observations are desired, valid time of a forecast, and basic time plus the forecast period. Parameters are specified by data type and level or layer. Some selection is based on the format. For example, surface temperature will be taken from the gridded field if the format is grid or contour, and from observations if the format is plot or list. Once the basic data has been selected, further control may be placed on what is to be used through the value of the data itself. When these options are applied to gridded data the parameter so constrained will be printed only at those grid points for which the criteria are met. When applied to contours, maximum and minimum will be used to select the limits of the contour values. This procedure has its greatest power and usefulness when applied to station data. In this case, the criteria will control printing of all data for the station. This may be used to select stations for printing based on the presence or absence of a certain weather element.

b. Maps. Any combination of station plots, gridded data plots, contours and background may be placed on a map. There is no restriction placed on the number of parameters to be overlaid on a map. However, if too many are requested, the map may be unusable due to clutter. The philosophy is that just the two or three parameters of real interest should be requested, however, the decision is entirely in the hands of the requestor. Since we are concerned with printer devices, there will be overlay conflicts in dense data areas. The computer is not capable of making priority decisions as to which should be plotted. The problem is resolved by giving the first data at a print position top priority. The decision is then passed to the requestor because data is placed on the map in the order it is requested. Thus, the most vital parameter should appear first on the request. In the case of station plots, if any character would be lost due to overlap, the entire plot is suppressed and listed separately along with its location, exactly as it would have appeared on the map.

(1) Plotting Model. Because of the complete variability of the data which may be displayed on a map, there is no fixed plotting model. Instead a model will be generated for each request.

(a) Data Positioning. There are positioning options to produce any desired model; however, these options will not normally be available to requestors. In the absence of these options the following method will be used. If any parameter is to be plotted as a single character, the first one will be placed at the station location. This allows an asterisk or sky cover symbol to be plotted at the station location. The other parameters

will be placed about the station in the order left, right, at, below, above. The parameter will be positioned in the order in which they appeared on the request. This gives control over the plotting model to the requestor. A request for a plot model might generate the following ten parameter positions:

10  
666 77  
1111322222  
44 5  
888 999

(b) Legend. A description of the plotting model will be printed to clarify the positioning of the parameters. This legend will include a sample plotting model and a description of each parameter.

(2) Contours. Only gridded data fields may be contoured. This is not normally a restriction, since most parameters found in reports are analyzed to a gridded form. The lines will be drawn using a single character for each parameter. Any character may be used. There are assumed characters for each data type. If the same type is to be contoured for more than one level or time period on the same map, it will be necessary to give a different character for one of the data fields.

(a) Interval. Any contour interval may be requested. Care should be taken to keep the interval large enough to avoid map clutter. The standard contour value may be set by using the offset option. The contour line actually drawn will be offset plus or minus multiples of interval. A maximum and/or minimum may be set on the contours to be drawn.

(b) Label. Contour lines will normally be labeled with the last digits of the contour value. This may optionally be suppressed. High and low centers and their values may optionally be printed.

(3) Background. Background is broken into four categories; latitude-longitude, geography, political and topography.

(a) Latitude-Longitude. The latitude-longitude lines may be requested in several forms. Normally intersections of certain latitude and longitude lines will be marked and the lines labeled. Optionally the lines may be filled in to make a solid line. Interval and offset may be specified for the lines to be drawn. Also, any characters may be used for the lines.

(b) Geography and Political. The geography and political backgrounds are essentially different densities of the same type of information, which includes geographical and political boundaries. Geography includes continental boundaries and boundaries between large countries. Political includes smaller scale geography, state boundaries and the boundaries between the small countries.

(c) Topography. The topography will be available in variable densities with local topography to the nearest 100 feet.

c. Vertical Profiles. Two types of vertical displays are available. They are the Skew-T and the Route Cross-Section. The vertical coordinate of the map may be either height or log pressure.

(1) Skew-T. The Skew-T is a true vertical map consisting of plotted and/or contoured values of any of the vertically defined parameters. It is derived from observations,

analyses, or forecasts for one point in the horizontal. The vertical scale and extent may be varied in any manner. The extent is specified by giving the upper and lower altitudes for which the mapping is desired. The "fold" option may be used to display the upper atmosphere overlaid on a lower portion. This reduces both the horizontal and vertical size of the display while presenting all available information. The data may be obtained from any combination of station observations, gridded analyses, and gridded forecasts. The horizontal scale of the Skew-T will be parameter value and may have a different meaning for each parameter. Parameters which are to be plotted rather than contours will appear at the edge of the chart at the specified altitudes.

(2) Cross-Section. The cross-section is a plot of the specified parameters in the vertical for each of the specified points. The vertical coordinate is the same as for Skew-T (altitude is to scale). The horizontal coordinate is not to scale but represents the track specified by the given points. The points will be separated sufficiently to provide readability but will not be scaled by distance.

d. Data Listings. Data listings serve two purposes. One is to provide access to all the data for selected stations in tabular format. The other is to provide special tabular format for computer to computer transmission.

(1) Tabular Format. Tabular displays will consist of columnar displays spread across the page with each column separated by two blanks. The spacing may be adjusted by using the position options. Each column will be headed by a title. This title will give the level and parameter. If there is no level associated with the parameter or all levels are requested, the level portion will be blank. A special parameter and level is available to cause printing of the levels corresponding to all levels requested. Unless otherwise stated, the columns will be from left to right in the order in which they appear on the request.

(2) Station Listing. Data selection for station listings is identical to that for plotted maps; that is, stations will be selected by the area or by the station list. Reports will be selected by parameter and time. If criteria values are given for one or more of the parameters, some of the reports may be discarded. The complete report or any part of it may be displayed. The format of the display will be tabular by station and altitude.

3. Data Formatter and Display. To process and display large volume of satellite data, the AFGWC uses a Data Formatting and Display (DF&D) system. Unique equipment has been acquired to convert data from analog to digital form, allowing rectification and refinement and to convert the refined data back to analog form for picture reconstitution on photographic paper or transparencies. This will permit printing of contours and other data directly on the picture.

a. System Configuration. AVCS ground stations receive, and send ESSA satellite cloud data to NESC, at Suitland, Maryland. The AFGWC receives the same data in analog form via a drop on the long line. The Data Formatter (DF) of the DF&D system converts the data from analog to digital format. The result is a raw data tape, ready for processing on the UNIVAC 1108 in the rectification program. After rectification the data is made available for computer analysis, as well as, for the display device which produces transparencies or photographic hardcopy.

b. Analog to Digital. A satellite photograph is composed of many scanlines of information. When the data is received, each scan line can be thought of as being represented by a smooth continuous curve. To digitize this data, brightness values corresponding to the point on earth are assigned at fixed intervals along the curve. With values at known locations, the data is now in a format suitable for further processing.

c. Increase Usefulness. The rectification program processes the data to improve its usefulness. Some of the steps will be briefly described in order to have a better understanding of the final product.

(1) Lens Distortion. The lens distortion, due to the refraction of light rays in passing through the lens, is removed. The distortion is assumed to be radial. Corrections are made based on information received from the lens manufacturer.

(2) Vignette Neutralized. The vignetting effect, decreasing intensity of illumination from the center of the satellite photograph, is neutralized.

(3) Edge and Overlap Crop. Some of the data on the edge of the orbital strip photographs are unreliable. There is a certain amount of overlap in successive pictures along an orbital path which produces redundant data. Removal or cropping of this unreliable or redundant data substantially improves the picture usability.

(4) Mapping. The latitude-longitude lines on earlier satellite photographs did not correspond to any standard projection (i.e., mercator, polar stereographic, etc) and hence could not be used with standard weather charts. Part of the AFGWC effort is directed toward mapping the satellite data to a mercator or polar stereographic projection, at various scales corresponding to standard weather charts for a more useful product.

(5) Solar Illumination and Scattering. The response of the camera system is affected by the sun angle and atmospheric scattering. The variance at points throughout a photograph are considered by normalizing the solar illumination and scattering.

d. Location. The rectified data for each orbit (sunlit portion only) is located in computer storage on a 1024 x 4096 point grid. This provides a resolution of about 1.7 nautical miles at the equator and 3.4 nautical miles at the pole. The 1108 computer time required to completely process the information received for one orbit of coverage is approximately 25 minutes.

e. Display. The display of rectified cloud data is on photographic paper which has 14 inches of usable width. A single picture or orbital mosaic can be displayed at variable scales and with overlaid latitude-longitude lines, labels and legends. Options to display contours and data plots are being developed. The display is in 16 shades of grey--0 corresponds to white, 15 corresponds to black, and the intermediate numbers correspond to the respective intermediate grey shades.

4. Command Control System Support. Fundamentally, our mission is to be sure each decision maker has considered the PERTINENT weather information before he makes each weather sensitive decision. To do this we must have the latest information available on a real time basis and display it for the customer in the most useable form. The AFGWC has the largest automated environmental data handling system in the world. To be effective it relies upon the multi-program operation of four scientific processors linked to four high speed communication processors throughout the world. The SAC Automated Command Control System has sophisticated automated printer and multi-color projection display equipment. AFGWC development work is underway to direct drive this automatic display equipment to provide to SAC the kind of information which upon receipt at AFGWC is determined to be operationally critical, as well as to provide displays of SAC requested information. Automated weather support of this nature will expand to other command control systems (MAC, SAC, NORAD, etc) during the 1970's.

a. SACCS. The SAC Automated Command Control System meets the need for rapid transmission, processing and display of information to support the command and control of the SAC force. The dedicated communications network and associated headquarters equipment

provides reporting, data processing and presentation capabilities. Urgent or critical information is displayed as it is received. In this manner, personnel at SAC Headquarters and the three SAC numbered air force headquarters are alerted to matters which have implications for operations, material or communications control. Headquarters personnel can also request display of data which have been previously stored in the system.

(1) Subsystems. The SACCS is made up of three subsystems. They are the data transmission (communications), data processing and data display subsystems. Direct drive of the data display subsystem by AFGWC for weather displays will utilize the AFGWC/SACCS computer link and the communications subsystem while bypassing the SACCS data processing subsystem. Actually the AFGWC UNIVAC 1108 system will, for SACCS purposes, act as the weather subsystem.

(2) Data Display Subsystem. Information can be displayed in a tabular form on printer and/or in multi-color tabular and map formats projected on wall screens. Displays are requested by data request panels which are located in the command post of each headquarters. Printers are located throughout the headquarters, as well as in the command post proper. Printer output can be transmitted to any printer within the SACCS; where as, wall screen displays are limited to the individual headquarters command post. Displays are converted to wall screen projections by an automatic photographic wet processing technique in the Group Display Generators (GDG) which produce 70 mm positives in multi-color.

b. SACCS Weather Displays. Messages containing weather displays in tabular or map form will be activated in the weather subsystem by requests or by the weather parameters themselves, as they pass thru predetermined critical threshold values. The messages are then transmitted via the communications subsystem to the appropriate display device in the SACCS.

(1) Tabular Display. There is nothing new about tabular data formats displayed on printer devices. However, the SACCS capability to automatically generate and project multi-color tabular and specifically map displays on wall screens, is of particular interest and will be described in more detail in the following paragraphs.

(2) Map Display. The map display when projected on the wall screen is made up of a multi-colored background map depicting a predetermined geographical area and a dynamically generated data overlay.

(a) Background Map. In the present system there are 53 background maps in varying projections (Lambert conformal, mercator and polar stereographic) scaled from approximately 1:2,000,000 for the United States Sectionals to 1:32,000,000 for hemispheric areas. They are in multi-color with communist countries colored red, non-communist countries colored brown or light blue and water areas colored dark blue. Latitude - longitude lines are also depicted. The maps are on 70mm slides in a manually replaceable carousel. Background maps can easily be added, deleted or changed in the system.

(b) Data Overlay. The dynamically generated overlay can be tabular, plotted and contoured or any combination thereof. The seven colors available are red, green, blue, white (red, green, blue), yellow (red, green), magenta (red, blue), and cyan (green, blue). The map display program has the capability to produce 63 different map symbols, and improvise other characters by combining two or more of the existing characters. Contours can be constructed from a series of dots.

(c) Wall Screen. There is a set of four 16 foot square wall screens in each command post on which dynamically generated displays can be projected by the automatic

projection equipment. The background map is projected from the Still Picture Projection (PSP) equipment and the data overlay is projected from the Group Display Generators (GDG). Projection is from the front and may be the complete 16' X 16' image or an 8' X 8' image on any one or combinations of the four quadrants. The screens are labeled by letters (A, B, C, D) and the screen quadrants are numbered 1 to 4. This letter/number combination provides a screen/quadrant address for wall displays.

(d) Display Mode. The typewriter and position mode are the two methods of placing characters on a wall screen. In the typewriter mode the 8' X 8' quadrant is made up of 72 columns and 48 lines with a total of 3,456 character positions. Each of these character rectangles can be further broken down into 70 smaller squares - 7 squares wide by 10 high - of which only 5 wide and 7 high are used for the actual character styling. The 5 by 7 rectangle is located in the upper left-hand corner of the 7 by 10 rectangle, thus providing the display system with "automatic" character and line spacing in the typewriter mode. In the position mode the 7 X 10 character rectangle is utilized to divide the quadrant into 241,920 smaller micro squares. This enables any character to be positioned exactly where desired by specifying the horizontal and vertical coordinates on the screen. In essence, we have a very fine mesh grid with 504 locations in the x direction and 480 location in the y direction on each quadrant in which to position data depicted by combinations of the character set.

(e) Resolution. The capability to position characters on the micro squares makes it possible to produce fine resolution displays. However, the resolution is dependent on the scale of the background map. For example, on a United States Sectional map of the mid-west with a scale of approximately 1:2,000,000, the location accuracy of placing a dot on the mid point of a micro square is 1.4 miles. The size of the characters is a limiting factor, and in this case the resolution of the display device is equal to 3.0 miles, which is the diameter of the dot. Hence, the present capability to position meteorological information on the SACCS wall screen displays is at a finer resolution than the information we have to depict.

(f) Contouring. The utilization of appropriate software and display hardware to produce contoured meteorological displays will be the first extensive use of this capability in the SACCS display subsystem. Testing has verified this capability to be economically feasible on a timely basis. Proposed multi-colored contoured displays include synoptic patterns, cloud/weather conditions affecting military missions and mission route/weather depiction of condition for training operations.

#### IV. Outlook

1. Display Methods. The three basic display methods (technique and equipment) at AFGWC -- Selective Display Model (SDM) for printers, Data Formatting and Display (DF&D) for photographs and SAC Automated Command Control System (SACCS) Group Display Generators (GDG) for projections will be in routine operational use by early 1970. Continued refinements, improvements and additions to the techniques and displays will enhance support capability to a certain extent.

2. CRT. The CRT equipment will be used for input of mission information to the AFGWC data base, for modifying output and for final checks of output. Instead of rerunning entire numerical grid outputs to correct mistakes, the CRT can efficiently provide a blown up picture (zoom capability) of that portion of a grid which needs modification to improve quality or correct an error. Snapshots of final products on CRT's will aid real time quality control.

3. Needs. Weather simulation display equipment is needed to depict multiple parameters in four dimensions. To see the simulated conditions resulting from a number of variable weather parameters interacting over a period of time would be a very valuable research and forecast tool. Faster line drawing equipment with multi-color capability and speeds equivalent to high speed printers are needed to replace the slower plotters of today.

THE NAVY WEATHER RESEARCH FACILITY PROGRAM  
FOR THE DEVELOPMENT OF A FUNCTIONAL DISPLAY AND PRESENTATION SYSTEM

E. C. Kindle  
Navy Weather Research Facility  
Norfolk, Virginia 23511

ABSTRACT

The contemporary and projected problems of arriving at forecasting judgements are diagnosed. The projected developments in the pertinent basic sciences and supporting technology indicate a promising potential for much improved environmental support to military operations. However, the continued practice of trying to force the advancements in science and technology into the operating procedures and physical environment left over from the 1930 era, not only wastes the benefits of the advanced developments, but in some cases cripple the existing operational approaches. On the other hand, there is a danger of camouflaging existing deficiencies in formal logic and "know how" by assuming that straining of all data through a computer memory applies the blessing of truth regardless of the truth in the computer instructions.

A Navy Weather Research Facility program to develop a system and procedures to permit the implementation of computer and data processing technology and at the same time accommodate the fullest level of contemporary knowledge of atmospheric processes will be presented.

This system and program is merely an element of an overall program being conducted by the Facility. For any meaningful understanding, this element must be reviewed in context of the major program. The actual lapsed time in completing research tasks ranges from 1 to 4 years. For specific programs, additional time for "tooling up" in personnel and facilities extends this lag as much as 2 additional years. For these reasons CAPT SOMERVELL and I undertook the formulation of a comprehensive general ten-year research plan for the Research Facility, including a more specific program for the first 5 years. The time lag, inherent in completed research, is a critical factor in the usefulness of applied research, particularly in view of the scientific and technological developments that were imminent at that time.

In the formulation of this plan, we first attempted to establish the nature and scope of projected environmental support requirements. However, because of the recent and projected dramatic developments in the basic sciences and technologies, it became clear that the most critical problem facing the applied research organization was the development of the specific techniques and procedures whereby the overriding major scientific and technological developments could be integrated into the operational system. It was further concluded that for optimum effectiveness, Navy Research Programs would be critically dependent upon developments in four general areas:

- (a) Basic Sciences of Meteorology and Oceanography,
- (b) Communications, Data Storage, Data Retrieval and Data Display,
- (c) Instrumentation and Measurement,
- (d) Computer Capability and Peripheral Exchange.

To establish meaningful projections in these subject areas, we spent about 3 months discussing, probing and soliciting opinions from experts in all of the above diverse disciplines in both governmental and private agencies. To maintain an updated level of understanding, this selective interviewing approach has been established as a continuing process at the Facility. From our own experience, we unreservedly endorse this particular conference and its theme as a most important input to effective R&D planning.



In view of the agenda and the participants gathered here, it would be presumptive to elaborate on the details of the resulting diagnoses. However, some of the concluding results are relevant to the development of our display system.

Significant developments in satellite meteorology, constant level balloon technology and conventional data measuring systems plus dramatic developments in communication technology would provide a two-order magnitude increase in the total descriptive information that would be potentially available to the operating system of the 1970's. A three-order magnitude increase in the computer capability plus clearly evident significant advances in numerical weather prediction would escalate the quality and volume of operational numerical weather predictions in the 1970 era. In summary, it became clear that the prospects were bright for a marked general improvement in the quality of meteorological support during the next ten-year period.

Appraisal of our research studies indicated that unfavorable environmental conditions degraded naval operations to an extent of 25% to 30% of the fair weather effectiveness. Probably only about half of this figure could be recovered, even with perfect forecasting. However, if the projected scientific and technology development could be realized at the operational level, it seemed quite reasonable that a recovery of 20% to 40% of this residue in lost effectiveness was a realistic objective. This would amount to a 3% to 6% contribution to overall Navy operational effectiveness. With a conservative estimate of 16 billion dollar annual Navy budget, the stakes are high and warrant a sober effort on our part.

In spite of the highly professional and dedicated efforts of the contemporary operational services, the greatest deterrent to more extensive use of environmental support is forecast reliability. The use of air/ocean predictions would increase exponentially with improvement in quality of environmental support. Many operations cannot accept probable uncertainties in contemporary forecast service; and the commanders are forced to degrade their operations through over caution or to play adverse condition roulette with the environment, taking the full losses when they occur.

As a final step in the WEARSCHFAC diagnosis, vulnerable research areas of particular importance to the Navy were selected as prime targets for our research program. These involved problem areas in which a strong combination of Navy requirements and high probability of success ensured a high payoff; or, problems which were highly critical to naval operations but not commensurately emphasized in the national level effort. These included such problems as:

- (a) Tropical Analysis and Prediction in General; and, Tropical Numerical Prediction in Particular,
- (b) The Prediction of Surface Winds and Weather Phenomena Over Ocean Areas, and
- (c) The Specific Prediction of Operationally Significant Weather Phenomena.

In these three somewhat overlapping areas, it was clear that the projected developments in science and technology would provide great stimuli and perhaps make significant improvement possible. But, it was also clear that a great deal beyond the projected national development would have to be accomplished or the preponderance of the projected progress would be denied the operational forces.

From our diagnosis, we concluded that the 1970 era promised to be an exciting era for the meteorological profession. A significant need exists; and the prospects for the capability to satisfy this need are bright. However, the major operational services are presented with a major planning problem to accommodate the projected progress of the 1970's. It is certain that the already overextended forecasting systems left over from the 1930's could not be stretched or patched further to accommodate the projected step function of information input.

At the present time the volume of information that is pumped into forecast delivery echelons is already well beyond the saturation point. With the three-order magnitude increase in computer capability, compounded by a two-order magnitude increase in operational satellite (and other) data, any further stretching of patching becomes ludicrous. Large scale automation is the obvious answer. But probing further, it becomes clear that this presents a major problem and could not just be turned on or resolved by "Black Box" engineering. The technology inside the required "Black Boxes" just isn't up to it.

I'm sure that scientists charged with improving forecasting services are tired of clichés and lamentations describing the lack of techniques to predict actual weather phenomena. However, this is the crux of the problem. I'd like to use a rhetorical device, applied by Professor Clarence E. Palmer in diagnosing the woes of tropical meteorology, and pose the question:

"Why have our meteorological scientists failed in development of a comprehensive rationale for forecasting the actual weather? In retrospect, this is a silly question because they haven't failed! They couldn't fail because they haven't really tried."

This amplification does overstate the case; but, reviewing the relative allocation of research resources directed toward the analysis and prediction of phenomena versus the prediction of thermo- and hydrodynamic parameters, only the totality of the statement is vulnerable. In very recent years the emphasis in this problem area has certainly increased. I refer to the progressive programs of the Techniques Development Laboratory of ESSA, Directorate Scientific Services of AWS, and our Navy Weather Research Facility, as well as the scientific service components of field activities of the major services. However, from a recent rough appraisal, less than 5% of the national research resources are dedicated directly to the prediction of actual weather phenomena. Even within major operational functions, this particular problem receives less than 20% of their own technique development resources. In retrospect, the existing inadequacy of actual forecasting capability should come as no surprise. There may be many reasons for this, most of which would invite extensive philosophical debate.

The truth is, gentlemen, we just don't know how to bring off an exclusively "push button" system. The success of the dynamicists in numerical prediction of the large scale, mid-latitude, middle and upper tropospheric motion fields is impressive. While we must totally appreciate these accomplishments, unfortunately, we cannot totally emulate them. We simply haven't done our homework well enough. The most successful contemporary numerical prediction accomplishments draw upon only a fraction of our current knowledge of the science. There are volumes of descriptive and analytic information covering nearly all scales of physical processes and phenomena that is not getting into the system. While much of this knowledge is too fragmentary to permit a total formal analytic treatment, the preponderance has already lent itself to quantitative understanding and diagnosis of significant atmospheric processes and problems. Even less of our total knowledge is getting into the existing operational forecasting systems, which further reflects the deficiency in the present state of the applied science.

We face an enigma; we can handle only a fraction of the total available information (or that which will become available) without extensive automation. On the other hand, we can handle only a fraction of our total knowledge of atmospheric processes and phenomena through total automation.

We submit that the problem of "how should forecasts be made" should be aggressively explored. We don't think there are any quick answers to the question. We are sure that the existing marriage of the large automated numerical complexes to outmoded operating locations is leading "nowhere." We are equally sure that total automation will be equally ineffective, for "Garbage in and Garbage out" would be a worse solution. This latter approach, however, does create a false sense of security by removing the perpetrators of the forecasts from the wrath of the users.

I anticipate being deluged with the new, but well worn, bromide that any deduction a human can make, can be programmed for a computer. This has been repeated so glibly and so often that this non-valid premise is accepted as an axiom. This is probably the result of confusion between the states of "in principle" and "in fact." If there is any place automation could help humanity, it would be in the medical profession. "In principle," a systematic input of symptoms and examination results could be fed into a computer, which would immediately provide a diagnosis and dispense pills with instructions; or, possibly direct the punch card holder to assume a certain position for a cybernetic hypodermic needle to provide the same discomfort currently dispensed by tender loving hands. You might envision letting a ZANIC MOD II sever an umbilical cord but the thought of it going after your appendix might make the adrenalin flow freely. Similarly, computer technology could help the

overburdened aircraft controllers; but, the total substitution of automation in the control towers would be a real boon to the railroad industry.

In time, the age of automation will unquestionably contribute to these professions; but, many years of development will separate the "in principle" and "in fact" states. The comprehensive order with which both these professions apply basic knowledge to practice is considerably more developed than in our own profession. Hence, we would be deluding ourselves if we try to by-pass this large and critical applied development problem.

The problem of "how should forecasts be made" must be addressed in a broad front. We need to know how many echelons are necessary to the system, the extent of automation and human judgement appropriate at each echelon, as well as the skill levels in diverse sub-disciplines required at each level to accommodate the maximum extent of technology and state of the science. This will require a whole new approach to the forecast problem and a series of experiments in which potential operating systems can be simulated. The present system by which our personnel are trained in nearly every phase of our science except forecasting, and then sent into the world with only a "voodoo" guidance to provide numbers for very serious users, is long overdue for overhaul.

Since the estimated timelag for anything substantial in such a program is about five years, we decided to develop a versatile system that would permit simulated projections of the scientific and technological environment. The first question to be addressed is, "Can we develop a formal rationale for making actual weather forecasts, using the tools that will be available?" Needless to say, this system should use ATS data in lieu of GOES, Nimbus in lieu of ITCS and simulated anticipated numerical prediction capabilities. But more than that, it should try to incorporate as many known physical and descriptive principles as possible in the development of formal forecasting rationale. Ultimately the developments must be assessed in context of realistic logistics of time, people and money.

Since our knowledge of communications, display and cybernetic technology was rudimentary, we attempted to enlist the aid of experts in these fields to design our simulation system. A diagnosis and proposed approach prepared by a well-known communications research organization only proved the converse, i.e., they knew too little about our problems to come up with anything realistic.

The development of such a system becomes, of itself, a research task. For a most effective system, a general design should be formulated in modules and should be acquired incrementally to permit the experience obtained by using each successive increment to contribute to the design of the subsequent increment. The base system has been procured and installed, and the second increment has been contracted for and will be delivered in March 1970.

It must be emphasized that this system is not programmed as a development model for an operational system. It is intended as a research device to accommodate the utmost of human judgement and numerical technology in the development of a rationale for forecasting the weather. Obviously, one of the more important by-products of its application will be guidance in the development of future operational systems. Hence, rather than as a prototype for future operational systems, it would more appropriately be labeled a forerunner. Experience to date has already provided several useful guidelines for follow-on systems.

We envision the meteorological wallpaper and eyeball processing system being replaced by a system that permits electronic storage of a large volume of conventional weather charts, satellite pictures, computer products, alphanumeric data, etc. In addition, a random access capability would permit immediate display and presentation on an array of viewing surfaces of any of these data, singly or in multicomination overlay formats, in diverse colors or black and white. Any chosen sequence of data could be animated at desired speeds in single sets or in multicolored overlays. Any given animation set could be looped to permit time for adequate human registration. The system could be linked with a computer, which would, on demand, take any selected set of data from storage and prepare grid point or contoured analyses in any combination of x, y, z and time coordinates. These could then be displayed in the same multicolor and multioverlay combinations. The computer system, on demand, would rectify and scale any chart from a video disk or from the computer memory as required to provide overlay compatibility. By the use of light pens and cross hair cursors, the forecaster could demand computations of special functions for special areas or zoom to any degree of higher viewing resolution required.

## BASE ECHELON OF DISPLAY SYSTEM

### DISPLAY SUBSYSTEM

TWO MONOCHROME AND TWO COLOR TELEVISION MONITORS

EACH OF THE MONOCHROME MONITORS MAY DISPLAY ANY ONE OR COMBINATION OF ANY SEVEN STORED ITEMS

EACH OF THE COLOR MONITORS MAY DISPLAY ANY ONE OR UP TO FOUR STORED ITEMS, ALL IN DIFFERENT COLORS

ALL FOUR MONITORS OPERATE COMPLETELY INDEPENDENT OF EACH OTHER

### STORAGE SUBSYSTEM

#### VIDEODISC ANALOG STORAGE

STORES 250 SAT, PHOTOS, MAPS, CHARTS, ETC.

RANDOM ACCESS SYSTEM ALLOWS ACQUISITION OF ANY STORED ITEM IN 10 SEC. OR LESS

ANIMATION ALLOWS "TIME LAPSE" PLAYBACK OF SEQUENCES OF SAT PHOTOS, MAPS, ETC.

MULTIPLE READOUT PERMITS SIMULTANEOUS PLAYBACK OF UP TO SEVEN DIFFERENT ITEMS

Figure 1

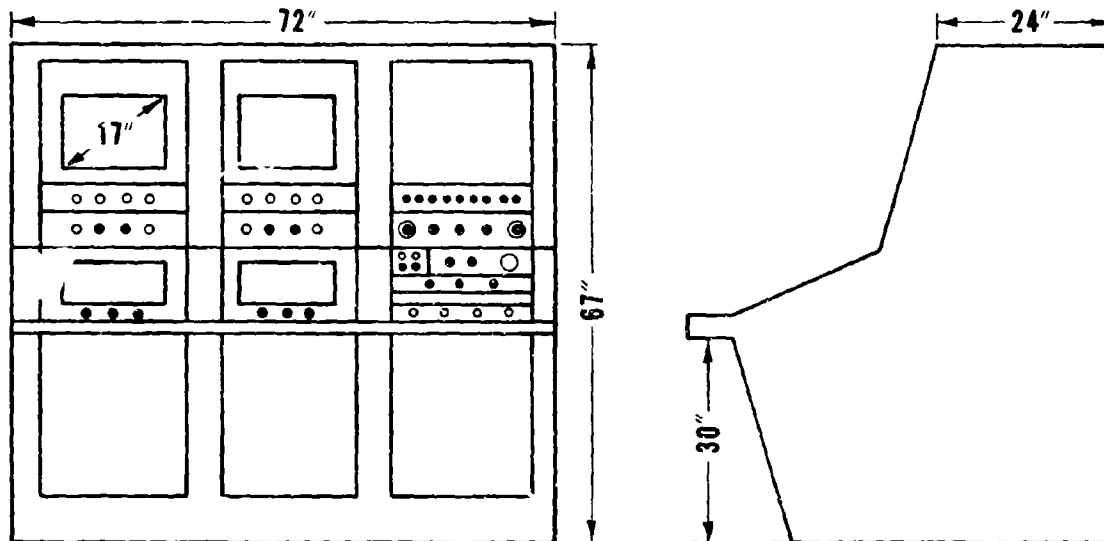

Display System Console

Figure 2

It was presumed that the total flow of information into a forecasting complex could be automatically and electronically stored and would include radar, APT, satellite (both IR and VIREC) alphanumeric, band index, aircraft, computer products and even the obsolete facsimile data. An automatic sequence of display would be programmed according to a formal forecasting rationale and adjusted to fit the schedule of data receipt, and would present and display the data in predetermined format and rate. A forecaster at the console would be able to accelerate, decelerate, or interrupt this sequence, at will, for special computations, diagnoses or presentations. A large store of climatic, historical, and reference data would already be residing in the system in pictorial graphical or alphanumeric format which could be accessed and considered immediately on demand.

For example, we would presume that the basic prediction input into the system would be the output from the large scale numerical prediction center (or centers), and include both large scale and high resolution predicted fields of gridded data. The forecaster could fit his latest data (conventional, radar or satellite) to projections of these predictions in whatever format was suitable. He could immediately demand some special advection or radiation transfer computations for any given domain. He could institute a search for an analogue of GOES satellite pictures or radar data in an overlay format. He could integrate large scale numerically predicted motion fields with high resolution topographic domain to compute and display the resulting high resolution motion, temperature and moisture fields. By the use of light pens and cursors he could subjectively correct his numerical aids in the computer memory, which in turn could automatically dispense or present his final product in pictorial, graphical or alphanumeric format.

Where the final numerical product offers the ultimate, by all means that would be used. Our efforts will be concentrated on the subject areas where the projected numerical capabilities have the least promise, i.e., at the air/ocean interface, in the tropics and the prediction of actual weather phenomena.

The foregoing hardware capability sounds a little visionary; but, gentlemen, by February of next year 60% of this hardware capability will be a reality, and 35% is in place and in use now.

The search for principles and procedures is a major task before us. The hardware is not the problem. We are not deluding ourselves about the magnitude of the procedural development problem. In the next five years we shall make a significant dent in developing the applicable procedures, and hopefully will be able to realize more comprehensive benefits by sharing our results with the other similarly directed research programs.

The base increment of the system, which is now in use, consists of a random access video-disk analogue-storage subsystem, a 4-unit television monitor-display subsystem and a TV-vidicon camera-input subsystem.

The display subsystem is comprised of two monochrome and two color TV monitors. Each of the black and white monitors can display any one, or any combination of seven stored frames, which can be arbitrarily faded in and out. Each of the color monitors can display any combination of up to four stored frames all in different colors. All four monitors can operate completely independently of each other (see fig. 1).

The storage subsystem can accommodate up to 250 frames of maps, charts, pictures, and alphanumeric data. The random access system can scan the whole disk in less than 10 seconds and provide animated sequences at any desired rate from 8 frames per second to one frame in 20 seconds.

The TV camera input is mounted on a motor-driven "zooming" frame with multiple lens-focusing capability which provides up to 800-line resolution storage from photographs or charts from a half inch square to one yard square in size.

The dimensions (72" x 67" x 55") of the whole unit excluding the TV camera are shown in figure 2. One each of the color and black and white monitors is mounted at a quasi-horizontal working level with a corresponding arrangement in a quasi-vertical reference frame.

Figure 3 is a photograph of the console attended by the two-legged subsystem. Figure 4 shows four simultaneous data sets displayed on the system. Unfortunately, our photograph



Figure 3  
(Original in colors)

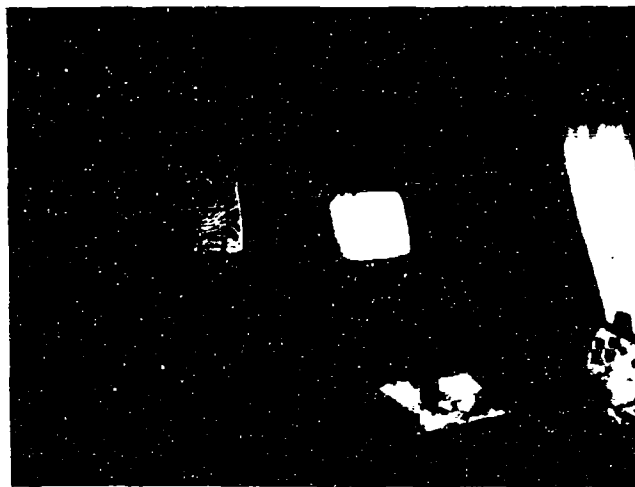

Figure 4



Figure 5  
(Original in colors)



Figure 6  
(Original in colors)



Figure 7  
Original in colors)



Figure 8  
Original in colors)





Figure 9  
(Original in colors)

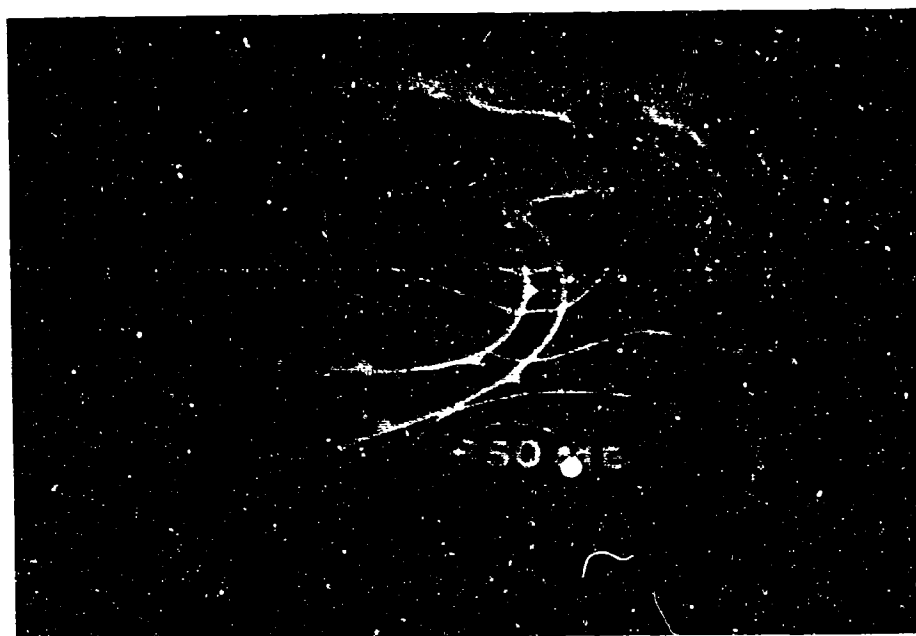

Figure 10  
(Original in colors)

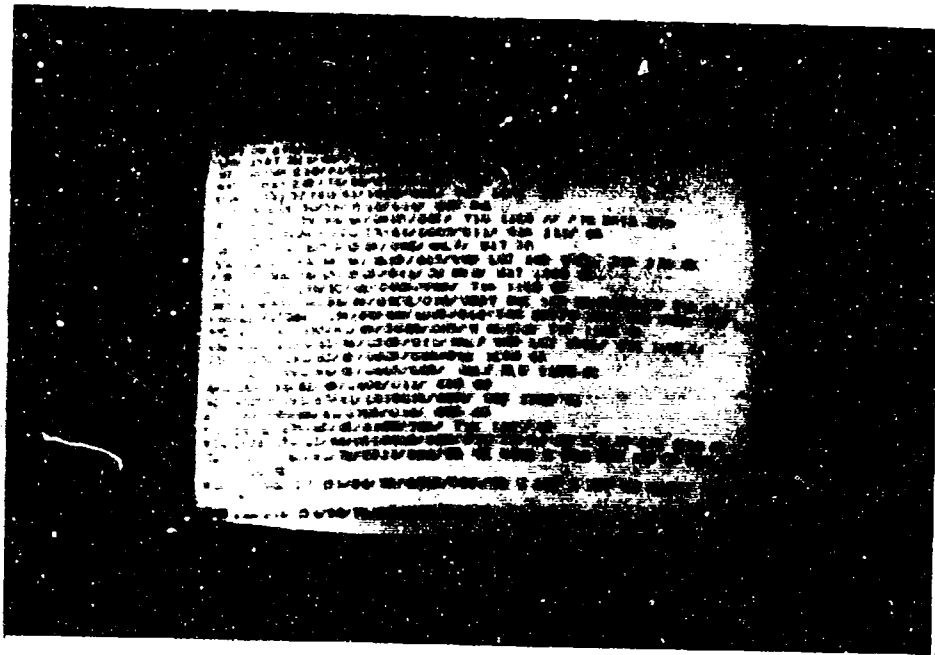

Figure 11  
(Original in colors)

## SECOND PHASE OF PROGRESSIVE DISPLAY SYSTEM

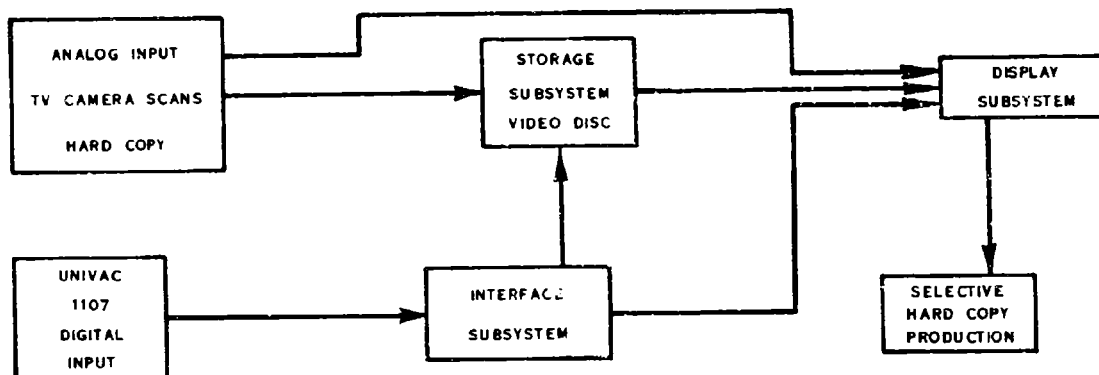

Figure 12

## DEVELOPMENT OF TOTAL SCHEDULE FOR DISPLAY SYSTEM

FY 69	BASE SYSTEM VIDEO DISC AND TV MONITOR SYSTEM
FY 70	CROSS HAIR CURSOR 1107 INTERFACE (VIDICODER) D/A CONVERTER
FY 71	TAPE RECORDER A/D CONVERTER HARD COPY OUTPUT
FY 72	ENLARGED FLAT VIEWING SURFACES ADDITIONAL DISK MULTICHANNEL ANIMATION REMODEL CABINET REMODEL CABINET
FY 73	LIGHT PENS TO SUPPLEMENT CROSS HAIR CURSOR INSTALL CONVENTIONAL TELETYPE AND FACSIMILE INTERFACE MODULER DESIGN FOR OPERATIONAL SIMULATION
FY 74	INSTALL AUTOMATIC PROGRAMMABLE SEQUENCER INSTALL FILM, RADAR, AND APT INTERFACE

Figure 13

leaves much to be desired and does not do justice to the clarity of the actual display system. The viewing surfaces show some conventional weather charts, a teletype sequence and satellite picture. The contents of these displays are shown more clearly by close-up views in figures 5 and 6. If the forecaster wants a topography overlay instead of the surface isobars in the ATS picture, a quick dial with the touch tone could provide something like figure 7.

We can crudely show the overlay capability by a sequence of pictures (figs. 8 through 10). Figure 8 shows a tri-color overlay of a surface, 850- and 500-millibar chart. By flicking a switch, the 850-mb. chart is removed, leaving only the surface and 500-mb. charts (figs. 9 and 10). Flick another switch and the 500-mb. chart is isolated. Should the forecaster want to look at some hard copy data, similar action would bring him precisely what he wants instantly (see fig. 11).

We prepared two animated sequences for this presentation. One was an ATS sequence of Hurricane PEGGY and the other was an impressive 30-day sequence of surface charts showing successive surges in the Northeast Monsoon, and their associations with the 500-mb. pressure troughs moving across northern Asia from the Ural Mountains. Unfortunately, because of conflict in frame speeds, the movies of these animation sequences did not turn out; however, the stimulation of thought and reason through dually displayed sequences was dramatic.

At the present time, we are studying animated sequences of the Northeast Monsoon of Southeast Asia and ATS sequences of tropical cyclones. Within one month we shall receive a completed UNIVAC 1107 computer program that will convert the natural camera projections of ATS photos to a Mercator projection of any desired reduced area and corresponding increased resolution. Using these pictures, we are confident that we can obtain wind direction and velocities from successive cloud positions for studying characteristic tropical circulation models.

By the time we have completed the transfer of a whole year of ATS data to a Mercator digital format, the second increment of the system will be installed (see fig. 12). This is the second most important increment of the system in that it provides an extensive interface with the UNIVAC 1107. The computer will be able to rectify scales and resolve any desired projection area of a digitized satellite picture, and transmit it directly to the disk by means of a D/A converter. In addition, a cross hair cursor will be installed to be used with any of the monitors with a manual control linked to the computer by automatic location and reference registers. These precise location and reference data can be stored directly in the 1107 system for computations and/or processing. In addition, control of the 1107 will be transferable directly to the display console and be supplemented by a keyboard entry capability.

This will complete the first major capability for the type of research objectives we have planned. Using the ATS pictures we shall develop a facile method for fixing successive cloud locations which are to be fed to the 1107 for computing the lower-level wind field and incorporate it with conventional data, finally producing a derived stream line analysis field. This in turn will be transferred to the video disk to be overlaid in sequences over the original cloud pictures. We anticipate the total process will be able to be accomplished quite rapidly.

We shall also develop a procedure for overriding numerical surface wind forecasts by subjective reasoning, thus providing improved input into sea and swell forecasts. In this effort, we have initiated a sizeable parallel research program to define the physical processes which govern deviations in characteristic situations and areas. With respect to the region of North Atlantic Gulf Stream in winter and the Southeast Asia Northeast Monsoon, we have a good handle on the problem at this time. It appears the technique will be applicable to research a more extensive area of the ocean surface. I would prefer to go into more detail in these scientific procedures but my hosts haven't given me that license. I'll conclude by describing the schedule of development for the total system.

The five year growth schedule is given by figure 13. The procurement for FYs 68 and 69 has already been covered. The scheduled additions for FYs 71 through 74 are given below:

(a) FY71 -

- (1) An analogue tape recorder storage, interfaced with the disk to pre-serve experimental data and permit application of the system to

intervening experiments with a minimum of initializing effort. In addition, the tape recorder can serve as auxiliary storage to expand the total capacity of the system.

- (2) An A/D converter to complete the interface with the 1107 to permit analogue data from the disk to be digitized, processed and modified within the 1107.
  - (3) A hard copy output device which will permit dry process output of near wet process quality of data from the disk or the computer memory at the rate of not to exceed 10 seconds per copy.
- (b) FY72 -
- (1) Enlarged flat TV monitors will have been marketed for 2 years and, by that time, should be at a sufficiently reliable and economic level to supplement (or supplant) the existing conventional monitors. These larger flat viewing surfaces will be much more suitable for subjective interface.
  - (2) An additional disk to augment the total storage and random access capacity.
  - (3) A second animation channel to permit simultaneous viewing of animated sequences such as satellite or radar sequences overlaid on or paired with the high-frequency output of numerical predicted parameters.
  - (4) These additions will require remodelling of the console.
- (c) FY73 -
- (1) Light pens to supplement the cross hair cursor to expand and facilitate human intercourse with the system.
  - (2) Direct interface with conventional teletype and facsimile circuits.
  - (3) Modification of design to permit operation in modules to simulate various echelons in the forecasting service; i.e., numerical complexes, centers, facilities, carriers and non-meteorologically manned locations.
- (d) FY74 -
- (1) An automatic programmable sequencer to minimize the complexity of operating the system. This will automatically present data and displays, in sequence and in combination, in accordance with schedule of data availability and a pre-programmed forecasting rationale.
  - (2) Direct interface capability for film, radar, and AFT inputs.

The present state of knowledge of our science could permit much more reliable weather predictions and with the projected growth of knowledge we could do even better. To achieve this fulfillment, we are faced with both a problem and a danger.

The problem is the development of the principles and procedures to entrain the fullest state of our knowledge into a system which also accommodates the ultimate state of technology.

The danger is that the pressure of "push button" chauvinism will implement a premature over-automation program that not only denies the total use of our understanding of meteorological processes, but precludes the subsequent development required to adapt basic knowledge to practice.

Since I began by expounding this doctrine, this is a good place to stop. Thank you!

## ON LIMITS IN COMPUTING POWER

Willis H. Ware \*  
The Rand Corporation  
Santa Monica, California

At one time or another you have probably all heard of the growth figures quoted for the computing industry in the double decade of 1955-1975; these figures are part history and part extrapolation, but to the extent that history has progressed since the estimates were made, the extrapolations are valid. In these twenty years the size of the computer has decreased 10,000-fold for equal computational capability. The unit cost of calculation is down by the startling figure of 200,000-fold, while speed has increased 40,000-fold. Also, there has been an explosive growth of installed capacity, which over the double decade of 1955-1975 has increased 160,000-fold. The '70s have been extensively analyzed and projected, and by 1975 or so machines ought to operate close to  $10^9$  operations per second. This morning I thought it would be more exciting to move on into the '80s to see what limits might set a ceiling on computational capability. These thoughts do not reflect original research on my part; rather I have tried to extrapolate from the work of others. There is no universal agreement about the arguments on which I draw, so my conclusions must be considered as "ballpark" guidelines.

Although I recognize that we can conceivably get increasing capability from software improvements, or from better numerical analytic techniques and better mathematics, I want to avoid these issues today and talk about: (1) the hardware, particularly with respect to component speeds and the limitations imposed by the laws of physics; (2) the logical arrangements used to implement arithmetic; and (3) the overall machine architecture.

First, let me address the question of arithmetic logic. Several years ago Winograd<sup>1</sup> of the IBM Research Laboratory undertook to investigate the maximum speed with which arithmetic can be done. The parameters of the problem are obvious: the length of the numbers to be handled, the so-called fan-in of the logic element (the number of signals one logical element can accept), the base of the number system (binary or decimal), and the delay time for the logic element. Winograd was able to establish a formula that predicts the absolute minimum time in which addition can be done. In order to achieve such a minimum, numbers will have to be represented in remainder, or residue form, rather than in conventional positional notation. Winograd also addressed the question of multiplication, and he found that in some cases multiplication can actually be done more rapidly than addition. Again, the numbers have to be expressed in a special way. The stickler is that addition and multiplication require different special representations.

Therefore, it would appear that an inevitable compromise between addition speed and multiplication speed will have to stand. At this time, it does not seem worthwhile to design a machine in which numbers have two special representations for the sole purpose of speeding up arithmetic.

Winograd's analysis brought an additional point to light. Such operations as overflow determination, as well as any operation that depends on it such as COMPARE, cannot be speeded up. As we know computation today, overflow indication is essential; and, therefore, representation of numbers in such special ways as residue form is not an attractive option.

---

This paper is not a formal research product produced for a client of the Rand Corporation. Thus, it is not the view, official opinion, or policy of Rand nor of any of its governmental or private research sponsors. However, it does reflect the general participation of the author in the Rand research program and his immersion in the Rand research environment. Papers are published by the Rand Corporation to support the professional activities of its staff members.

<sup>1</sup> S. Winograd, "On the Time Required to Perform Addition," *J. Assoc. Comput. Mach.*, Vol. 12, No. 2, April 1965, pp. 277-285; *idem*, "On the Time Required to Perform Multiplication," *J. Assoc. Comput. Mach.*, Vol. 14, No. 4, October 1967, pp. 793-802; J. F. Freenan, "The Fastest Time of Addition and Multiplication," *IBM Research Reports*, Vol. 4, No. 1, 1968 (a digest of the two Winograd papers).

In fact, well-designed contemporary machines do addition at roughly 60 to 80 percent of the Winograd limit. When one considers that machine designers have had no metrics to guide them, this is a remarkable achievement. On the other hand, multiplication is running a quarter to a third of its maximum rate; but even so, it does not yet look worthwhile to represent factors in special form to enhance multiplication speed. The significant conclusion is that any big gains one can anticipate in computers will not come from the logical arrangements to implement arithmetic. We might squeeze 10 to 20 percent in addition and/or 50 percent in multiplication, but there will not be orders-of-magnitude improvement from the logical implementation of the arithmetic processes.

If we examine the arithmetic unit (CPU) of contemporary machines and ask how efficiently it is used, we discover that it is idle a substantial amount of time; typically CPU utilization is about 50 percent, and it can be lower. There are bottlenecks in the internal information flow; e. g., the arithmetic unit is frequently waiting for the memory or for the magnetic tapes. Thus, the efficiency of utilization is not as high as desired. More sophisticated designs to appear in the early '70s will provide a steadier flow of information to the arithmetic unit but there is only a factor of roughly 2 or 3 to be gained. Thus, it follows that any machine that performs only a single arithmetic operation at a time is within a factor of 3 to  $5^2$  of the end of the line. If such a machine is to improve any more, it must utilize faster components. It also follows that in the early or mid-'70s we will have to turn increasingly for super machines to the multistream concept such as represented by Illiac IV or some of the pipeline-machine processors now in design. In such machines, a large number of arithmetic operations are in process concurrently.

Let me next turn to component technology. Consider the conclusion obtained by Bremermann, of the University of California at Berkeley, and also formulated by Marko.<sup>3</sup> Bremermann has published twice the conclusion that no data processing system, be it artificial or living, can process more than  $c^2/h$  bits per second per gram,  $c$  being the velocity of light and  $h$  being the Planck constant. In one publication<sup>4</sup> he bases it on thermodynamical principles. This result can be challenged but if his limit stands, it has interesting consequences. If we insert values,  $c^2/h$  becomes  $2 \cdot 10^{47}$  bits per second per gram. Hypothesizing a computer of the mass of the earth and of the age of the earth, we find that such a machine could have processed only  $10^{93}$  bits in its lifetime. This appears to be an enormous number, but in reality it is small compared with some of the problems people are discussing. For example, the number of move sequences in a chess game is approximately  $10^{120}$ ; a straightforward attack on the problem would require a capability far beyond that of our earth-size, earth-age computer. Similarly, a picture of 100 by 100 cells, each of which can be black or white, contains  $10^{3000}$  different patterns. No doubt, some of the meteorological problems that are under discussion cannot be dealt with by a routine, brute-force, head-on collision with a super computer. The mathematical analysis will have to be very ingenious to bring such problems within range of attack.

Of course, we are presently nowhere near this limit, so let's discuss individual components. If we wish to store information, we need a device that has two potential wells separated by a barrier;<sup>5</sup> one potential well corresponds to binary zero, the other to binary one. To change the state of the device, energy must be inserted to move over the barrier, and if the device is expected to stay in the new state, the energy must be removed when the new state is reached. The random energy of motion is of the order of  $kT$ , so that if the device is to

<sup>2</sup>This is a composite figure including a factor of 2 to 3 for CPU efficiency and one of  $1\frac{1}{2}$  for pushing arithmetic to the Winograd limits.

<sup>3</sup>H. Marko, "Physikalische und biologische Grenzen der Informationsübermittlung," *Kybernetik*, Vol. 2, No. 6, October 1965, pp. 274-284

<sup>4</sup>H. J. Bremermann, "Optimization through Evolution and Recombination," in *Self-Organizing Systems 1962*, Spartan Books, Washington, D. C., 1962, pp. 93-106.

<sup>5</sup>Idem, "Quantum Noise and Information," *Proceedings of the Fifth Berkeley Symposium on Mathematical Statistics and Probability*, Vol. IV, University of California Press, Berkeley and Los Angeles, California, 1967, pp. 15 - 20

<sup>6</sup>R. Landauer, "Irreversibility and Heat Generation in the Computing Process," *IBM J. Res. and Develop.*, Vol. 5, No. 3, July 1961, pp. 183-191.

behave reliably, the barrier must be a few  $kT$  high.<sup>7</sup> Thus, the minimum energy that needs to be expended per information event is of the order of a few  $kT$ , but the significant conclusion is that energy must be dissipated as heat. Unavoidably, computing involves dissipation of heat; there is no way to circumvent the problem if we are to build a computing device that is to be reliable.

The next consideration is that computation destroys information. Thus, it is a nonlinear process and depends for implementation on logical functions that are also nonlinear and that depend in turn on nonlinear phenomena for practical realization.<sup>8</sup> Nonlinearity of electronic components also contributes to the practical problems of the computer; e. g., restandardization of signals, fabrication tolerances, and noise rejection. In the present solid-state technology, signals of a quarter volt or so are necessary to maintain the nonlinearity of the  $p-n$  junction in semiconductors and to absorb fabrication tolerances. This is not a limitation of a theoretical law of physics but rather a state-of-the-art limitation. It is anticipated that improved devices -- not of the semiconductor type -- will be found that maintain nonlinear behavior with signals 10 to 20 times smaller. Because a signal of finite voltage amplitude is inevitably necessary, capacitance-charging problems set a final limit to the speed at which a component can operate.

We consider now the velocity of light that is an absolute limit on the speed with which information can move. If we want to build fast computers, we must build small ones; and we will have to package them densely. However, small size and dense packaging are inconsistent with heat dissipation. The heat dissipation problem appears to be a more serious constraint than any others now visible.

Let me suggest the scale of the problem. In modern-day transistors, the power density inside the transistor at the  $p-n$  junction is of the order of thousands of watts per square centimeter.<sup>9</sup> In contrast, the maximum heat transfer to fluids at approximately room temperature is about 100 watts per square centimeter. There is a factor of 10 or so that somehow has to be accommodated. Obviously, we need to spread the heat over a large enough surface so that it can be transferred to a fluid. Thus, the mismatch between internal working power densities and external fluid absorption power densities is a major constraint on the minimum size of components, and hence on the speed with which they can operate.

Where are we today? Thin superconducting films can be switched in research environments at about  $10^{-10}$  seconds.<sup>10</sup> The capacitance-charging problem in semiconductor junctions sets limits at about  $10^{-11}$  seconds. The time for carriers to drift across the base of a transistor, given the technology that we can project for making very small base widths, is of the order of  $10^{-10}$ . We can switch magnetic films in about  $10^{-9}$  seconds and magnetic cores in about  $10^{-7}$  seconds. These are all state-of-the-art limitations. Interestingly enough, except for the core, they are all in the general neighborhood of  $10^{-10}$ .

Where do the laws of physics impose limitations? The cooling problem sets a practical limit on switching time at about  $10^{-11}$  seconds.<sup>11</sup> If clever engineering can solve this problem, we look forward to speeds of  $10^{-12}$  to  $10^{-13}$  seconds. Of course, there is a fundamental limit at  $10^{-15}$  seconds due to indeterminacy. Present research results are not very far from what appear to be absolute limitations, and thus, we should anticipate computing elements that will switch information states in about  $10^{-11}$  to  $10^{-12}$  seconds.

---

<sup>7</sup> $k$  is Boltzmann's constant, and  $T$  is the Kelvin temperature.

<sup>8</sup>M. J. Freiser and P. M. Marcus, "A Survey of Some Physical Limitations on Computer Elements," IBM Research Note, RC 2283, November 14, 1968, pp. 7-8. This article is to be published in IEEE Transactions on Magnetics, June 1969.

<sup>9</sup>Ibid., pp. 9-10.

<sup>10</sup>Ibid., pp. 12-14

<sup>11</sup>Eugene G. Fubini, private communication to the author. See also R. W. Keyes, "Physical Problems and Limits in Computer Logic," IEEE Spectrum, Vol. 6, No. 5, May 1966, pp. 36-45.



Where is the state of the art today? Present production devices switch in about  $10^{-8}$  seconds, and present research items switch in about  $10^{-9}$  to  $10^{-10}$  seconds. Depending on what one wishes to use as a "practical" upper limit for component speed and what one chooses as the present-day state of the art in research, there is a factor of at least 100 (from  $10^{-9}$  to  $10^{-11}$  seconds) yet to be realized from component technology speed. If we can push beyond  $10^{-11}$  to  $10^{-12}$  seconds, we will have a 1000-fold improvement, but with present understanding of the theoretical and practical limits, it does not appear that factors beyond a few thousand will ever be achieved. Even the minimum improvement of 100-fold is an impressive future to contemplate.

Machine architecture is a difficult subject to treat. Most of the experience in the computing field has been with machines executing a single instruction stream, doing one arithmetic operation at a time, and organized internally so that the arithmetic unit is maximally utilized. Experience with multistream machines is limited. Taking into account the estimates of the Illiac IV machine, which is about as multistream as now envisioned, and discounting somewhat the hopes of its builders, we may be able to achieve an increase of 100-fold (as opposed to projected factors of many hundreds). This factor depends strongly on how much of the problem is inherently serial; 100-fold implies that 1 percent of the problem is serial. Combining this with the smallest factor of  $10^2$  that component technology has yet to go, we may eventually get as much as  $10^4$ , or a 10,000-fold increase in raw computing power. If problems prove to be "more parallel" than we think, or if we do push technology even further, the overall improvement could move toward 100,000-fold. This is an even more impressive future to anticipate for the environmental problems with which you are concerned.

Any such mammoth machine would be very special and probably warranted only for the problems that could exploit it. The commercial industry is not likely to build such a machine unless a large market appears. Construction, at least for the first one, will no doubt have to be funded separately, and if your problems need such computer power, be prepared to finance the development of such machines and to dig deeply into your budgets. I won't project the development cost, but it will be substantial although probably less than a large particle accelerator.

Acknowledgments: I appreciate the critical review and very helpful comments from M. Warshaw and J. C. Shaw of The Rand Corporation, Dr. Rolf Landauer of IBM, and Dr. Eugene Fubini, consultant.

## THE ARMY'S AUTOMATIC METEOROLOGICAL SYSTEM .

Donald M. Swingle  
USAECOM, Atmospheric Sciences Laboratory,  
Fort Monmouth, New Jersey

The Automatic Meteorological System is being developed for Army 85. Used in the Field Army areas, it will serve all consumers of meteorological data and weather information in the Field Army, including Air Weather Service teams and centers. The design of this system will emphasize integration of the system with operational units so as to provide the most representative and accurate data possible for each data user. Development philosophy and design concepts, including communications and computer problems, are considered.

### I. Introduction

Fellow meteorologists, scientists and engineers, I will discuss in this paper the initial concepts of the Army's Automatic Meteorological System (AMS). I will cover the general conception of the meteorological system revolving about the user, his atmospheric problems, his pervasive need for data and the properties of atmospheric data. I will then discuss the outer system comprised of the atmosphere, the meteorological system, the user, and the atmosphere's effects upon him as he uses our meteorological data and finally the inner meteorological system. I will also cover briefly atmospheric system design and development principles, special problems faced by a meteorological system which serves the Army, including as an integral customer the Air Weather Service Weather teams which directly support the Army. Finally, I will discuss computer prospects and their implications for communications of meteorological data in the Army.

### II. Atmospheric Effects On The Army

Figure 1 shows the origin of the problem. In simplest terms, the Army operates in and under the atmosphere and is impacted upon by the atmosphere. In a number of its operations, the impact of the atmosphere, if not corrected for or allowed for, would create intolerable adverse effects upon the Army's operations. A single example is the case of the Army's 8"-Howitzer that is so accurate that an error of one meter/second in the knowledge of the winds which will occur along the trajectory at the time when the projectile passes through the atmosphere produces an error as great as the sum of all the other errors in the gun system. The Army has a host of similar stringent requirements for quantitative meteorological data at quite specific points in time and space. This need for data will continue to increase in the future.

Emphasis on the need for precise, specific data applicable to a future time and place should not be taken to imply that there will cease to be a need for weather forecasting as it has been known, or for an outlook for five days, for thirty days, or for that matter for a year or more for the general weather conditions which will occur in the operational area.

Air Weather Service needs for outputs from the Atmospheric Meteorological System must be identified and quantified. These outputs will include edited and preprocessed data for relay back to Air Force Global Weather Center (AFOWC) and weather information for use by forward AWS teams.



FIGURE 1 - The Basic Problem for a Meteorological System

### III. Properties of Atmospheric Data

Atmospheric data for the Army must possess four properties:

1. It must be applicable, that is, data must be presented in such a way that the Army can use it.
2. It must possess the closely related property of representativeness. The quantities to be provided must be suitable or appropriate for the purpose for which they are to be applied. This is the basic reason why the Army processes upper air data for ballistic purposes in a way which is quite different from that which is employed by the rest of the worldwide meteorological community. The ballistic application is a severe task master. A well conceived error-cancelling scheme for wind processing is used by the artillery meteorological sections.
3. Army atmospheric data must be valid to the time to which it is to be applied. Often these time requirements are quite specific, e.g., "at the beginning of morning nautical twilight and for a specified number of minutes thereafter, will smoke generators be effective in a particular river crossing operation," or "how long will the fog last and when will it break?" Critical operational decisions can hinge on the precise timing of such changes.
4. Finally, the Army's requirements for meteorological data are in almost every instance, requirements for specific information at a very specific place. In the case of the ballistic requirement, the place is the entire trajectory of each individual round. In the case of river crossing it is the space of perhaps one-half mile along the river for which the prediction is required.

You will note that the meteorological data required are essentially predictions on the meso-scale. They must be timed to within a few minutes and be good over the area "where the action is", i.e., to a few kilometers or better.

a. The Outer System. In the face of such requirements for data, let us consider the atmosphere. As meteorologists, we have been educated in the Navier-Stokes equations. We realize that the fundamental properties of the atmosphere can be represented by a small number of basic parameters that are quasi-continuous in time and space, such as temperature, pressure, vapor pressure, and vector velocity. In addition to these basic hydrothermodynamic properties,

there are other parameters of interest such as clouds, precipitation, density, turbulence, visibility, refractive index, etc.

The central problem which we face with this atmosphere, however, is that it is very variable. For instance, our past studies have shown that the wind in any given 2000-foot zone in the atmosphere in the lower 20,000 feet can be expected to change by 4 knots in an hour, by almost 3 knots in a half hour, and extrapolating, by perhaps 1 knot in five minutes. Similarly, winds can be expected to vary in space by 15 knots in a hundred miles and by extrapolation, by 1 knot in half a mile. The meteorological system that will provide quality data for Army quantitative applications, must somehow cope with this variability problem. To the extent feasible, it must produce answers which minimize the unaccounted-for variability.

We have considered the outer system, that is, the cycle starting with the atmosphere and its properties; this must be measured and predicted by the inner meteorological system in order that applicational data must be provided to the user, in this case the Army and supporting Air Weather Service teams. The adequacy of the system is finally determined in active operations when the real atmosphere with its actual conditions impacts on the Army, which has adjusted itself in accordance with the predicted data.

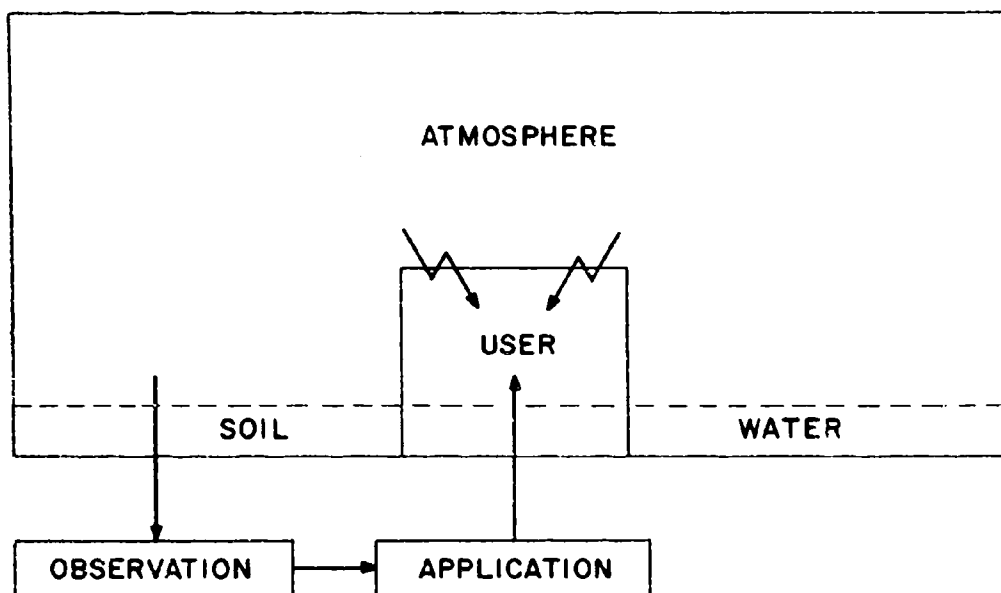

Figure 2. Elementary meteorological system.

By comparison with the Elsassser report of the late 1950's, it can be shown that wind data obtained in this way are more accurate for artillery applications than forecasted winds that can be generated by the weather services with the present techniques and in the present state-of-the-art. In any event, the test of the adequacy of the inner system in predicting or providing application data occurs when the operation is executed, that is, when the projectile passes through the air and the correction proves to be adequate or inadequate.

b. The Inner System. Let us now discuss the inner system, that group of operations and equipment which would normally be called a meteorological system. Figure 2 shows the inner system as it exists for the artilleryman. In order to correct for the effects of the atmosphere on gunnery, the artilleryman observes the atmosphere from the surface to some 20 km and applies the observed, measured, atmospheric data to compute a correction to his firing. This is a very simple inner system, but it contains an implied analysis that the atmosphere varies slowly in space and in implied persistence prediction of future conditions.

Figure 3 shows the complete inner meteorological system as a meteorologist might visualize it. A meteorologist would expect to:

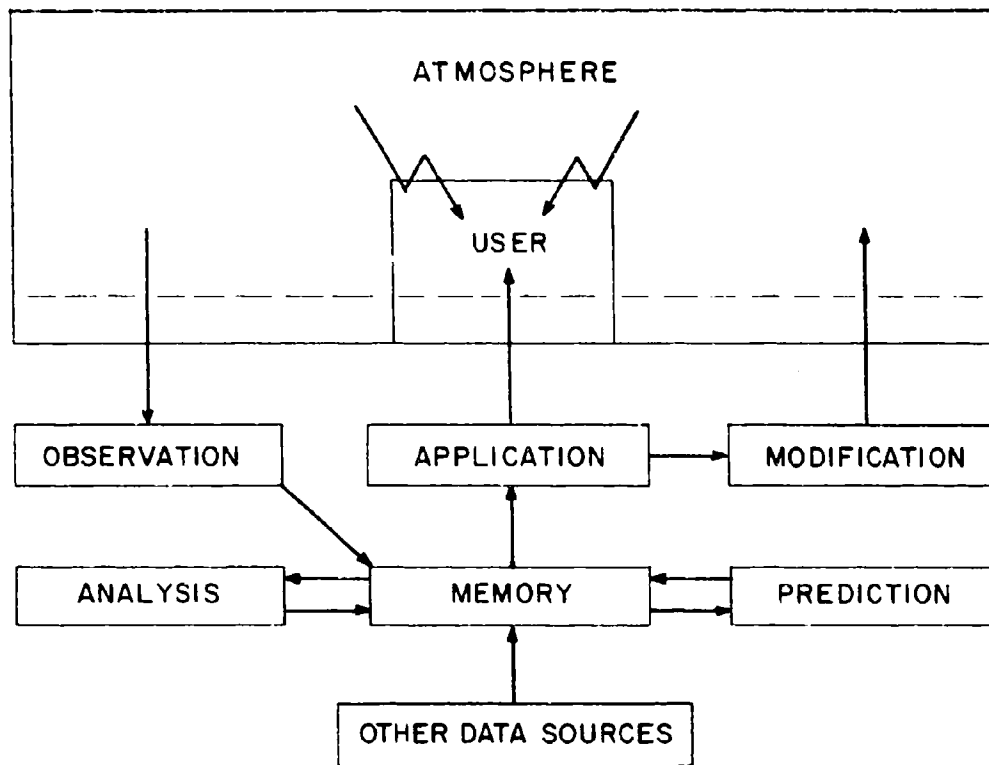

Figure 3. Complete Meteorological System

- 1) Observe the atmosphere.
- 2) Collect the observations into some sort of memory.
- 3) Analyze the collected observations.
- 4) Make predictions using these analysis.
- 5) Store these predictions in memory.
- 6) Provide data for Army applications.

A logical component of this system might be a modification element that could serve to make predictions more valid by ensuring that they come true, or by changing a correctly predicted atmospheric condition to a different, desired condition. In the following discussion I shall drop the modification subsystem from further consideration, although it may indeed become an important element in the long run for improving the accuracy and reliability of predictions.

c. Atmospheric System Design and Development Principles. Figure 3 shows the flow of data. Let us now shift our attention to the design of this inner system.

When we wish to create a system to serve a purpose it is necessary to turn first to the application of the system. The application of the Army's Automatic Meteorological System is to provide required meteorological data and weather information to all Army users, including the Air Weather Service teams. A point of contact for all these users, therefore, is the output of the system, the user interface, which is the dissemination and display portion of the system. In many instances, this output will be in the form of computer messages which will go directly into the computation or evaluation of meteorological corrections or adjustments of tactical operations. In other instances, it will be a visual display of information that is relevant to planning and conducting operations. Many of the techniques of the SACCS system may be applicable here if they can be made sufficiently rugged for Field Army use.

In the case of the Air Weather Service user, the output surely includes special displays of weather information that will be used by the Staff Weather Officer to gain the best possible understanding of the current situation so that he may best advise staff personnel of his expectations.

The user interface must provide the user with timely and appropriate data for each of his applications. Appropriate includes a requirement for quantitative accuracy equal to the users application. This quantitative data must come out of the prediction system.

Prediction techniques must be of such quality as to provide output data of the quality required as inputs to the user interface. This indeed is one of the major challenges of the Automatic Meteorological System for, in general, we have very weak techniques for predicting the smaller scale, local, meteorological conditions with quantitative accuracies which the Army will require. This is mostly outside the current state-of-the-art. In other instances, the prediction accuracies required may be well within the state-of-the-art and in this case the needs may be met by data already being received from the Air Force Global Weather Center or, indeed, by climatological values stored in the memory of the inner system.

Having specified the accuracy required of the output of the prediction system, we will be in a position to determine the accuracy required of the inputs to the prediction system in order to achieve these output accuracies. The input accuracies for the prediction system become the output accuracies for analysis system. It will be necessary that our analysis techniques be so conservative and so comprehensive as to provide inputs to the prediction system of such a high quality as to permit accurate predictions to be made for sensitive operations.

Our current techniques for analyzing conditions on the mesoscale and on the microscale are not fully adequate to serve as inputs to mesoscale and microscale predictions. Nonetheless, the progress of requirements from user to prediction to analysis is clearly a straightforward problem. We expect that vastly improved analysis techniques will be required that will take into account in quantitative ways the influence of the terrain on circulations and on the values of atmospheric variables.

The analysis system serves as the bridge from observed data to analyzed data. It converts more or less randomly-received observations of atmospheric variables at more or less random locations in time and space into a best-attainable understanding of the distribution of variables over the entire region of interest and throughout the entire height frame of interest.

In the case of any Army meteorological system, interruptions and inadequacies in the input data are expected. Although scheduled observations may be desirable and may be sought, it is inevitable in a tactical frame that these observations will either not be made due to other impacts of the operation, or that their transmission and reception will be delayed so that they will not be available for the scheduled analysis time. Furthermore, observations will not be available from the most desirable places. For instance, in approximately half of the region of interest, namely that over enemy held areas, very few surface observations can be anticipated and next to no upper air observations will be available.

The analysis system must nonetheless provide the best possible determination of conditions over the entire region of interest. To do this it will use larger scale inputs from the Air Force Global Weather Center and, in addition, the results of previous analysis and prediction cycles which will be used to produce prediction of the expected patterns. These, in turn, can be adjusted to improve their conformity with the limited observations that are received from the area in question. Thus, we expect frequent reanalyses to be made based on late-received or odd-time data, and on the basis of prior predictions and analyses. This will permit maximum value to be made of each observation, even of past observations and, in effect, will increase the total amount of information that goes into each analysis.

The collection and memory system is the necessary interface between the observations and measurements of the atmosphere and their analysis. Of necessity, the meteorological system must have a very large memory. It must encompass recent observations, analyses, predictions, and supporting climatological information. Such climatological information will become indispensable from time to time when other data sources are cut off by communications outages.

The input to the collection and memory system comes from the observation system. The quality of the observations must be good enough to permit the analyses that are good enough to serve as inputs to prediction.

Observations will come from both in situ sensors and from remote, indirect sensing systems. It is not likely that the obvious ideal solution of measuring everything, all the time, everywhere, will be logistically or tactically feasible. Therefore, the observation system can be expected to be composed of both direct sensors, which measure conditions at specific times and places, and of remote sensors, which can determine conditions over an area or throughout a volume. Considerable advance is hoped for with respect to remote sensors.

At present, satellite observations of clouds are available technologically, with a promise of satellite upper-air observations and the possibility of observing the distribution of clouds from satellite altitude in real time from points on the ground. Radar weather observation techniques can map the distribution of precipitation over both friendly and enemy held areas much better than the rain gauges can alone. There is also the previously developed "sferics" technique to maintain monitorship of lightning occurrence over both friendly- and enemy-held areas. In addition to these, other remote sensing techniques are very much desired.

One would like to be able to determine the wind throughout the volume over enemy-held areas and at inaccessible points over friendly areas both at the surface and aloft. Similarly, there is a need to determine the temperature or density patterns, and the pressure or contour height patterns throughout the area of interest. Indirect techniques for accomplishing this have been conceived, but the implementation of these in tactically feasible equipments remains to be demonstrated.

d. Other Data Sources. In addition to direct observational data, a large volume of background data is expected to be provided within the Automatic Meteorological System. This would include climatological data to the extent available and techniques for the interpretation and interpolation of such data, as well as a computer form for the shape and properties of underlying terrain features. Finally, other inputs must be provided for the memory, including inputs from the Air Force Global Weather Center, and other Weather Services. These will provide general weather information and also serve as a setting for the smaller-scale analysis to be conducted by the analysis system.

e. System Design and Development. Let us now turn to the system design and development problems. Clearly, the design of a practical field system must start with the application, and move backwards through the inner meteorological system to the acquisition of data. Thus, the first area of emphasis in the design of the Automatic Meteorological System will be a searching analysis of the users' problems, an in-depth technical study of each of the major applications of output data from the Automatic Meteorological System. This will determine the specific times, places, and properties of data that will be required for each application; the significance of errors and their cost to the Army in operational terms; and an analysis of the application to permit the design of techniques which will provide representative data for each application.

The Automatic Meteorological System is planned for Army '85. At this point we are in the early development stages in which intensive, applied research and prototype, breadboard designs are needed.

Above all other features required for an Army Meteorological System is the requirement for flexibility and survivability. The tactical Army environment necessitates a very rapidly changing setting, one in which data sources may be created and destroyed, rapidly, and in which communication links may be established and interrupted, depending upon the nature of

the conflict. Critical outputs may change quickly from those required to support smaller units in conventional war to those required under conditions of nuclear conflict. The Army force may deploy rapidly from moist-temperate to dry-tropical, arctic, or other environments.

Survivability under the impact of tactical operations is a critical factor. That is, one can anticipate conditions under which reception of all input data, or almost all input data will be temporarily interrupted. The system must continue to do the best job possible, using very limited amounts of locally-available information plus climatological data, and stored data from longer range forecasts and outlooks. This imposes a basic requirement for what has been called graceful degradation. The system must not be brittle or collapse when input data sources fail to provide input data, but must be able to make the best of each situation and of each condition of limited data availability.

As the system degrades, there must be preplanned backup modes. For instance, it is hoped that the Automatic Meteorological System will be able to provide improved accuracy of input data for the artillery ballistic problem. This improved accuracy will come from analysis of observations of the upper air stations in the context of their terrain setting and from the high quality prediction of future conditions for each trajectory to be fired. When, as it inevitably happens, the gunnery center is unable to contact the meteorological center with the result that the individual trajectory data is no longer available, a back-up message must be available and in memory at the gunnery center. This back-up message would contain a set of basic data applicable for the general region, that is, for an area of 40 to 60 kilometers radius surrounding the gunnery center for future times. The quality of this general data would not be as good as the latest prediction for a specific trajectory, since it would be more general and cover a larger area, but it would be of significantly higher quality than a prediction of no wind or a prediction of the climatological mean.

Should the communication outage persist for more than a few hours, the gunnery center should revert to the use of locally-observed data in much the same fashion as today's practice. And finally, should locally-observed data be unavailable, the system should shift into using such techniques as departure tables, that is, climatological means for various regions of the world. For each user a preplanned succession of back-up techniques must be provided as part of the meteorological system design. Only in this way will each user be assured that he is always using the best meteorological data available. One thing is certain, the entire system will not always operate reliably and with maximum input data to serve all customers. The enemy will see to this even if natural and electronic problems do not.

As part of the system design and development, it will be necessary to demonstrate the value of the system in relation to its cost. This will rest heavily upon the analysis of the user's requirements and the impact of atmospheric effects on his operations. However, consideration of the cost of one modern helicopter aircraft, or the price of a single round of artillery ammunition, or the investment of men and materiel in a single small army unit will readily show the tremendous value of a quality meteorological system.

f. Special Problems. A number of special problems must be solved in an Automatic Meteorological System. First there is the scale of Army problems. The Army typically operates over an area of about 100,000 square miles. The maximum range of most Army weapons covers a few dozens of miles. Major units such as a division, may occupy areas of only a few hundred square miles with approximately 30 miles of contact with the enemy. While the general weather forecasting problem is in fairly good shape and is well-handled by the Air Weather Service, the Army's special problem is providing specific local, accurate data for specific applications. The second special problem, already noted, is the pervasive expectation that inputs will be random not regular.



Related to this is the third problem, the knowledge gap relating to mesoscale phenomena. Although for a time it was thought that there was a gap in the atmospheric spectral distributions in the mesoscale, i.e., for circulations with periods of the order of one hour, there is no evidence of this in the Army's studies of atmospheric variability. These studies show a regularly decreasing variability for both wind and density as one moves from long times into short times. Although there is no gap in the spectrum, there is a severe gap in the current knowledge of atmospheric circulations on scales ranging from a few kilometers to a few hundred kilometers. The relatively coarse synoptic network has not provided data from which comprehensive conceptual models of such circulations could be developed. Theoretical models are of little use unless they represent accurately the actual behavior of the atmosphere.

For many of the Army's problems, the atmosphere's natural variability is so high that it is essential to observe, analyze, and predict on the mesoscale. Work in weather radar has shown considerable predictability and persistence of mesoscale precipitation patterns. However, present prediction techniques do not permit accurate prediction of other atmospheric variables on this scale.

A fourth special problem, and it is planned to avoid this in the design of the Automatic Meteorological System, is the death of technologies. Each of the various known techniques for predicting atmospheric variables has rested on a certain conception of what the atmosphere was and how it behaved. Although the "modern" trend is toward large scale digital computers, one may recall the very effective analysis and prediction technique that carried us through World War II known as the Wave Cyclone Model combined with the Polar Front Concept. Many are also aware of the isentropic prediction technique which was used just prior to World War II; it has since disappeared from the active scene, although a few recent research studies have used it. The design of the Automatic Meteorological System will try to take advantage of each technology and to blend the results obtainable by each in such a way as to get the most nearly accurate prediction feasible.

Finally, and the most important of the special problems, is the need for conservative processing of data. Since the Automatic Meteorological System will use computer analysis and prediction, to control the "garbage input" to the system it is essential to limit the "garbage output". A good example is the artillery ballistic computation and its differences with respect to the way that upper air winds are computed in conventional meteorology. In the artillery ballistic computation, the entire momentum of the atmosphere as observed by a balloon flight is accounted for once and only once. The end of each zone is the beginning of the next zone; there are no overlapping zones and no interpolations between zones. A consequence of this is that an integrated wind, which traverses several zones, results essentially in the cancellation of all tracking errors of the atmospheric sounding system, with the exception of the error at the top of the upper zone. In contrast, the conventional analysis into overlapping two-minute zones, and the further interpolation of these to specific heights, creates a confusion of errors and an inability to determine or to cancel accurately the contributions of errors from each observation point.

Another example of conservative processing exists in the analysis of upper air data in which there is a sort of negative feedback. This results in the cancellation or attenuation of the impact of errors in the measurement of pressure and temperature. Conservative processing will be emphasized in the design of the observation and analysis portions of the Automatic Meteorological System.

What kind of computer will be used in the Automatic Meteorological System? As noted here, the computer must include a sufficiently large memory of the climatology of the region, or for any region to which it must go. It will probably require knowledge of historical analogs so that today's analysis can be compared to prior analyses of the same region. In addition, extensive use of statistical techniques is foreseen. Such things as singularities, symmetries, and the

application of generalized harmonic analysis appear to be reasonable components of the system. The Automatic Meteorological System will probably include adaptive or learning systems so that it can develop quickly a capability for detailed prediction in a local situation in which there has been very restricted prior data. It must account for the four dimensional continuum, that is, three spatial dimensions and time, and it must preserve considerable detail in all four dimensions.

The solution to the equations of motion, which will be one mode of prediction, will almost be surely done in a hybrid computer system. This will be an important feature, different from current numerical weather predictions, that will be incorporated in an Automatic Meteorological System. The reason for this is that it allows the elimination in at least one dimension of the computational instability which goes with quantization of meteorological data. Most likely the simulation will be done treating time as a continuous variable.

Unless new techniques are developed, it will still be necessary to compute for each grid point, but each computation can be made without time quantization. For this reason a great deal of desirable nonlinearity can be tolerated and, if fact, is to be desired in the prediction system set of hydrothermodynamic equations.

In its most general terms it is expected that the computer of the future will be a hybrid machine in which data are stored in digital memory, but in which the processing is done by hybrid or analog systems wherever the prediction involves equations of motion and their solution. Where it involves the use of climatology or learning techniques, conventional digital processing will probably be used.

What are the communications prospects? As always, dedicated circuits are highly desirable from observer to memory and from memory to user. Such circuits will undoubtedly be desired and sought. However, the system will be designed to be as good as is possible under any condition of communication outage, including the delays and losses which result from the use of common-user circuits. A graceful degradation design will produce high quality products under conditions of reliable communications as well as a quality job under conditions of unreliable communications. The system analyses are expected to permit the importance, in terms of the improvement of quality of service, of dedicated circuits to be evaluated so that a rational determination of the type of circuits to be provided can be made prior to the introduction of the total system into the field.

**g. System Evolution.** The above discussion has considered an ultimate Automatic Meteorological System, one which will see field use with Army 85. This does not imply the absence of improvement in the interim. It is expected that the applied research that is done on the Automatic Meteorological System will lead to its evolutionary introduction. Perhaps this will be done first with improvements for the artillery, then for CB, then aviation as progress occurs in understanding each application; and finally as the development of observation analysis, prediction and application techniques progresses. The details of this evolutionary introduction cannot be spelled out today.

In the development of the Automatic Meteorological System, the Army is exploring the entire range of possible techniques for observation, analysis, prediction, and application. Every promising idea which surfaces will be considered for its possible contribution to the success of the system. The challenges are great; the potential pay-off in operations is almost incalculable.

LUNCHEON ADDRESS

Dr. Hans K. Ziegler  
Deputy for Science and Chief Scientist  
United States Army Electronics Command  
Fort Monmouth, New Jersey

Ladies and Gentlemen,

Needless to say, I am greatly pleased and honored to be here with you today, although I realize that my appearance in place of Major General William B. Latta, the Commanding General of the US Army Electronics Command at Fort Monmouth, must be sort of disappointing to you. You have met with General Latta during last year's Technical Exchange Conference at Fort Monmouth, and he was extremely interested in your activities, and your program committee had made an early decision that you would like to have him as your luncheon speaker here today -- but unfortunately, as we sometimes say if we refer to the Pentagon, "circumstances beyond our control" have at the last minute precluded his personal appearance. General Latta does indeed regret this very much. He was looking forward to meeting with you again and also to visiting Colorado Springs and to seeing many of his friends whom he acquired when he previously spent a tour of duty at NORAD. He specifically asked me to express to you his warmest personal regards and his sincere wishes for another fully successful conference.

I am afraid I have to disappoint you in one more regard. Not only will you be deprived of the general's personal appearance, but you also will not hear his speech. I have his speech and it is very good, but somehow I have never learned to give somebody else's speech. Some people can do this perfectly. We once had a Commanding General at our Fort Monmouth Laboratories, and many of you may know him, he later became Chief Signal Officer of the Army, and is now retired and is with industry. He was superb in presenting speeches from manuscripts which were prepared for him. Before I realized his unusual capability, I used to be a nervous wreck whenever he gave me an assignment to write a speech for him. I would comply promptly and submit the script early for his review and approval, and every day when I asked for his decision he just would say, "Hans, don't worry. Everything will be all right." And to my consternation this would go on until the very day of the presentation at which time he would take the manuscript from his desk, unread, walk to the rostrum, and make a perfect delivery. The General had attained quite a reputation for this unique talent. It was not until after his retirement that somebody was facetious enough to trip him up. I am not making this up for your entertainment; the General has revealed this episode to me with a great grin on his face. Again, he was in the middle of one of his splendid performances and as he turned to page 5 of the manuscript the page and the rest of the pages were empty except for a cryptic note which said, "and from now on, you so and so, you are on your own". And this is very much the same sentiment which befalls me at this point. But I felt I should say something here which comes from the heart rather than from a piece of paper.

Looking through the program of your Conference and attending this morning's session, I have been deeply impressed with the diversity and the depth of the subjects to be presented, and it did not take me long to be convinced that for one who is not directly actively involved in this special field, it would be pretty difficult to say something which can compete in significance with any of your program items.

Of course since you are my captive audience I could exploit the allotted time to do a long commercial for the Electronics Command and its meteorological activities at Fort Monmouth, White Sands, and Fort Huachuca, and for the former Signal Corps and for all these activities fine contributions to the field of atmospheric science as well as to meteorological equipment -- of which we are truly proud -- but since you are such a highly professional group, I am confident that you are all aware of these facts.

On the other hand, I could speak on generalities regarding the Army's important present and future needs in weather information and meteorological and environmental data about which I am deeply concerned in my professional responsibilities. I would have to think here about the entire spectrum of vital needs:

- the greater general weather support, short range and long range, including climatological information for overall Army-wide planning and utilization,
- the greater special weather support to commands and staff for operational decisions,

- the need for improved fallout predictions for nuclear, chemical, and biological warfare,
- the need for improved ballistic meteorological support, and those who have followed General Westmoreland's pronouncements and speeches on his experience in Vietnam, realize the tremendous savings which could be obtained if we could shoot just a little bit more accurately,
- the greater need for Army aviation weather support,
- the continued need for terrain weather support to plot our moves on the surface of the earth,
- the increased requirement of meteorological support for reliable communications on the ground and through satellite links,
- and not to forget our interest in all aspects of weather and meteorological modification aspects which can assist the overall Army objectives.

But again, these are all facets of the overall task which you are specifically here to study during your Conference in much more detail than I could offer in a few minutes.

Of course I would be eminently qualified, like everybody else, to just speak about the weather and, by golly, could I give you a case history of the past twelve months, including the eight-hour ride to cover the forty miles distance between Fort Monmouth and Newark during a blizzard on a day where the New York metropolitan weather forecast predicted a 20% probability of light snow flurries!

But what I would rather like to do is to amuse you with some personal recollections related to the evolution of one of the greatest meteorological achievements of our time -- the meteorological satellites -- the TIROS, the NIMBUS systems.

When in early 1955, still under the wraps of high classification, the various United States government research and development activities were invited to study and prepare plans for scientific uses of small artificial earth satellites, with a maximum total weight of some 20 lbs, the type which eventually was to be launched with the Vanguard vehicle, we at Fort Monmouth immediately zeroed in on two major potential areas: communications and meteorology. Since the radio-relay type of communication satellite was soon ruled out within the IGY Vanguard program as an applications test rather than a scientific data-gathering concept, our efforts concentrated on the meteorological aspect. Through the ingenuity of a team headed by Bill Stroud and Bill Nordberg, both now with the National Aeronautics and Space Administration (NASA) and from the program, I realize that Bill Nordberg was to present a paper to you yesterday -- in spite of the extreme payload limitations, a first primitive cloud-cover observation satellite was designed in 1955, and after a remarkable debate within the meteorological scientific community as to the merits of global cloud-cover observations, tentatively accepted for the Vanguard program. It was originally designated only as a standby, but through the slippage in the schedule of other Vanguard payloads, it moved up quickly and was eventually placed into orbit in early 1959. Unfortunately, after successfully reaching orbit, the satellite was kicked by the accidentally re-ignited last and already separated rocket stage and it wobbled so badly the data reduction subsequently became virtually impossible. But, nevertheless, this experiment of a Fort Monmouth scientist and engineer team, most of whom have since transferred to NASA, was historically the first step toward the successful evolution of today's weather satellites. The concept was very primitive, just a narrow-angle-scanning photodetector since more elaborate systems were unacceptable with the severe weight limitations. If a television-type satellite undoubtedly was to be the logical next step, the creation of TIROS, which eventually represented the first of such advanced systems, would not emerge along a straight logical evolutionary path.

As many of you may remember, the period 1955-1960 was one of great competition, some inter-service tensions and the lack of clear and final mission assignments in the United States rocket, missile and satellite field. The Army had the original lead in the missile field with the REDSTONE and JUPITER systems, and it had already basically in 1956 a capability to launch satellites bigger than those that the VANGUARD would be capable to handle. But the national policy to clearly separate the scientific VANGUARD IGY effort from any military missile interrelationship kept the country's satellite effort at bay until, as you all

remember, the Russians surprised us with the launching of SPUTNIK I in October 1957.

At any rate, while the practical launching of satellites was held back by the VANGUARD schedule, the planning and designing of applications satellites was going on full steam in many places to be ready whenever the restrictions would finally be lifted.

We at Fort Monmouth worked at that time very closely with the newly established Army Ballistic Missile Agency (ABMA) at Redstone Arsenal, Huntsville, Alabama, and its famous commanding general, Major General John Medaris. I was the Signal Corps special assistant for Space Age Activities, and was in continuous contact with ABMA and particularly Dr. Werner von Braun and his team.

At some time in early 1957, I received an urgent call from General Medaris' office to immediately fly down to Huntsville and be prepared to stay at least a day or so. In Huntsville, I was received by Mr. Eberhard Ries, Dr. von Braun's deputy, who ushered me into a secure room and handed me with an air of great significance and secrecy a 2-1/2 inch thick classified report and invited me to spend the day reading the report and above all to study what role the Signal Corps Laboratories at Fort Monmouth could play in implementing the recommendations of the report. It was a fascinating day which I spent with this document which was the result of an ABMA contract with RCA Princeton on a project later called "JANUS." It represented a complete system study of a high-resolution worldwide television-type satellite-reconnaissance concept and it was well backgrounded against a previous study which the Air Force had already contracted in 1951 with the Rand Corporation as prime and RCA as sub-contractor. The system called for a rather complex satellite payload and a widely dispersed ground-support complex. It all seemed technologically feasible, but one concern came immediately to my mind: If this was to be a worldwide reconnaissance system which the Army was to establish, was not the Army going to run smack into a mission conflict with the strategic reconnaissance mission of the Air Force? And I certainly wanted no part of getting the Signal Corps involved in a mission conflict with one of its own children. I brought my concern to the attention of General Medaris' staff and received an explanation which at that time seemed to be reasonable. The argument went this way: The Air Force's strategic reconnaissance mission had the main purpose to locate in general geographical terms important military targets for the objective of destroying those targets by aerial bombardment in case of war. In the execution of this final goal it was essential to establish exact geometrical interrelationships by visual or radar observation between the target and the attacking aircraft, whereas the exact coordinates of the target within the geodetic grid of the earth were of lesser importance. On the other hand, an intercontinental ballistic missile defense system required the precise knowledge of the XYZ of the target in the grid of the earth and such accurate information could only be provided by a satellite-based system, and the Army, which at that time was and expected to remain the nation's missile arm, needed such a system for the execution of its mission. The system was therefore more properly designated as a target-acquisition and location rather than a strategic-reconnaissance system.

I returned to Fort Monmouth highly impressed and with a few notes which I was permitted to take and we started to analyze the system from an overall electronic standpoint. Again it all looked very feasible and practically within the state-of-the-art. But the required payload weights for the satellite were so excessive that it did not seem possible to expect implementation with rocket-vehicle types foreseeable in the near future.

ABMA had come to the same conclusion and had awarded in the meantime a new contract to RCA to work out a design for a more modest prototype of the satellite.

Shortly after the surprise launch of SPUTNIK I, and after ABMA had already received our Government's go-ahead on helping out the still delinquent VANGUARD project by launching Army IGY satellites, General Medaris called a crash meeting at Huntsville. The subject was the go-ahead on the limited target-location satellite system in which ABMA would take the launching-vehicle and launching responsibility, and the Signal Corps Laboratory at Fort Monmouth the responsibility for the payload and associated ground-support equipment.

I headed the Signal Corps delegation and after we spent considerable time personally with General Medaris, Dr. von Braun, and members of their staff reviewing and discussing the details of the RCA proposed design plan, I came to one clear conclusion: Sure, this was an outgrowth of the ambitious original worldwide target-acquisition and location-satellite concept, but in its simplified form the expected picture resolution was so limited that it

hardly could provide more than crude terrestrial outlines, land and sea masses, big rivers, but was far from being able to detect any military targets. Indeed, it would just be a very acceptable cloud-cover observation or meteorological research satellite. I discussed this conviction with General Medaris and suggested it might not be wise to implement the experiment under the designation of a cloud-cover observation satellite rather than to unnecessarily excite the minds of the nation and the world with a threat of a global-surveillance satellite which at this point really did not exist. But General Medaris strongly felt that degrading the satellite's goal would degrade priorities, and support to implement the project would be lacking. And so we proceeded in the joint ABMA-Signal Corps target-location satellite project.

A few months later, in early 1958, and as another consequence of the Russian SPUTNIK surprise, the United States established the Advanced Research Projects Agency (ARPA) which took on major responsibilities in the early space effort and had authority for mission assignments within the various United States services and agencies. Within the new mission assignments which ARPA established, the launching of a worldwide reconnaissance or target-location satellite by the Army was no longer in the cards. At this time, ARPA agreed, however, that the proposed project was indeed an excellent possibility for a meteorological satellite. And since this was then a scientific endeavor, ARPA considered sponsorship within the purview of its own mission responsibilities. Thus the project sponsorship was transferred in mid-1958 from the Army to ARPA with both ABMA and the Signal Corps remaining in the original phases of their technical responsibilities. Since the goal of the project was, however, now officially shifted from "surveillance" to "meteorology", a study group in which meteorology experts both from civilian and the military side played a key role was convened to review and revise the project to optimize the design toward the meteorological mission. This is when the infrared sensors were added to the regular television system and where a design emerged which we now know as the TIROS -- the television and infrared observation satellite.

Shortly thereafter, as further clarification was made within the missile mission responsibility between the Army and the Air Force, the rocket vehicle originally planned for ABMA for the TIROS could no longer be expected and vehicle and launching responsibility was transferred at that point from ABMA to the Air Force.

In April 1959, when ABMA itself had to again divide its responsibilities with the newly founded NASA, sponsorship of the practically completed TIROS was transferred from ARPA to NASA.

And so finally TIROS I was launched on 1 April 1960 under NASA sponsorship. The Air Force Ballistic Missile Division provided the THOR/ABLE vehicle and the launching; the Signal Corps at Fort Monmouth was in charge of payload and associated ground station, with RCA as the prime contractor. The NASA tracking and computer facilities and the United States Weather Bureau played a major role in the data gathering and analysis.

Thus, an effort starting initially strictly as a military endeavor, and after going through a remarkable process of changing responsibility, sponsorship, and goals, finally ended up in a splendid success starting the evolution of the meteorological satellites which in their further advanced form have since taken almost routinely a key role in our daily global weather monitoring, analysis and prediction process. And after serving initially almost exclusively an important civilian mission, the weather satellites have long again reached the point of acquiring additional new significance in also serving the military needs, not in the original surveillance, but in the meteorological area.

The meteorological field has a history of such important interplay between military and civilian aspects from its very beginning when the first United States weather service was assigned in 1870 to a military agency.

There is hardly another discipline in science and technology where there is closer inter-relationship and greater mutual interest of military and civilian agencies and, above all, where there is closer cooperation between both the agencies and individual scientists. The blend of speakers and participants in this conference is another manifestation of this fact which is so highly conducive to progress.

I just thought you might enjoy this little historical rundown on TIROS, which by no means is complete, as a light diet after this fine lunch, and before you return to the heavy diet of the program of your Conference to which I wish you full success. It was indeed a privilege to talk to you.

PROBLEMS AND PROMISES OF DETERMINISTIC EXTENDED-RANGE FORECASTING\*

Joseph Smagorinsky  
ESSA, Geophysical Fluid Dynamics Laboratory  
Princeton, N.J.

Abstract

Since 1949 the application of computational techniques to the integration of mathematical-physical models of the atmosphere, and more recently the oceans, have yielded a continuous enlargement of the predictive range of validity. Furthermore, recent refinements in our understanding of the ultimate deterministic limits of the large-scale atmosphere provide us with a clearer perspective of the levels of predictability to which we can aspire and the demands which will be placed on future theoretical models, observational systems and computing apparatus.

The latest advances in modelling indicate a present level of model viability, starting from real initial conditions, of the order of one week, provided crucial technological limitations can be removed. These stem from the critical need for better defining the structural details of the atmosphere through systematic and comprehensive observation and from the overwhelming need for vast increases of computing power. The former appears to be no easy task despite the great advances in platform and sensor development. The newly revealed specific needs cannot easily be met and present indications augur severe compromises. A major expectation is that the use of sophisticated models for data assimilation will permit greatly improved thresholds of information extraction from a given observational mix of technologies. Paradoxically this may at the same time materially improve our ability to predict short-range changes of the atmosphere. Moreover, specific computational experiments reveal the penalty being paid for computational compromises forced by existing computer technology, particularly in resolving the essential phenomenological scales.

Just as these technological limitations preclude full exploitation of existing model sophistication, they at the same time inhibit the future model development needed to extend the practical range of prediction beyond one week.

Limited experiments indicate that if one is to expect the practical deterministic range of prediction to approach the synoptic-scale deterministic threshold of at least three weeks, the global atmospheric system must be dynamically coupled to the oceans and the surface-hydrology system. This creates new computational and observational demands. In turn, however, one can envisage as a product, comprehensive prediction capability for the total atmospheric-oceanic-hydrologic system.

---

\*Dr. Smagorinsky's presentation covered much the same thoughts he gave in his Wexler Memorial Lecture to the AMS, which is published in full in Bulletin of the American Meteorological Society, May 1969, pp 286-311.

NUMERICAL WEATHER PREDICTION CAPABILITIES IN THE 70's  
A PERSONAL VIEW

Frederick G. Shuman  
National Meteorological Center  
ESSA - Weather Bureau  
Department of Commerce

The relaxation of four fundamental limitations will determine the progress of operational numerical weather predictions:

- (1) the limited power of computer machinery,
- (2) inadequacies of the observational network,
- (3) gaps in basic scientific knowledge, and
- (4) problems of numerical methods.

The balance among these limitations varies drastically with the scale and period to be forecast, in some cases a quantitative physical approach being prevented. Although uncertainties rise exponentially beyond the first quarter of the 70's-decade, there is good reason to expect, commensurate with progress during the 60's, increased accuracy of numerical weather predictions. Equally as important, extension of the period several-fold is expected, and applications to the meso-scale problem are likely before 1980.

I. INTRODUCTORY REMARKS

I must say I feel more than somewhat uncomfortable attempting a prediction in the range of 10 years. There is at the moment a controversy going on in the meteorological community over whether the limit of atmospheric predictability is 5, 10, 20 days or somewhat longer, and we only now at the National Meteorological Center (NMC) have become prepared operationally to extend modern dynamical methods to 5 days. But here we are gathered, attempting a 10-year prediction of predictability.

I have decided to approach this question as a problem of limits. In this way, I hope first to lay out the vast area of what we can reasonably expect not to be able to do before 1980, and then to discuss a variety of possibilities.

Operational numerical weather prediction (NWP) as we now conceive it has four fundamental limitations, all of which must be relaxed for continuing progress:

- (1) limited power of computing machinery,
- (2) inadequacies of the observational network,
- (3) gaps in basic scientific knowledge, and
- (4) gaps in basic mathematical knowledge (e. g., numerical methods).

For discussion today, I will consider the first two.



## II. THE COMPUTER LIMITATION

Figure 1 shows computer speed plotted on a logarithmic scale against the year of acquisition for NMC's operational use. Unity has arbitrarily been assigned to the speed of the CDC-6600, the computer currently used for operational prediction. The figure also shows a straight line connecting the 1st operational NWP computer, the IBM-701, and the CDC-6600. This line is extrapolated to the year 1980.

With this crude trend method of prediction, machinery with speeds 350 times the CDC-6600 may be expected, as shown in the figure. The computer shown by the point marked "A" is in existence now, and its production is going forward. I have plotted computer "A" in the year 1971 as a reasonable year of acquisition for operational weather use. Point "A", therefore, is relatively certain as a prediction, and shows we are still near the growth rate of 53% compounded annually, projected throughout the 1970's.

There is another development taking place, of which I am sure you are all aware. The most optimistic estimate for the first ILLIAC-IV to my knowledge was based on analysis of a simple calculation related to an NCAR (National Center for Atmospheric Research) model, and showed a speed advantage of 300:1 over the CDC-6600. This is undoubtedly an overestimate, first because of the limited nature of the analysis, and second because the clock in the design subsequently was slowed. If we optimistically assume a 500:1 advantage of ILLIAC-IV over the 6600 and assume acquisition for operational use in 1973, our 53% growth rate yields machinery almost 10,000 times as fast as the 6600 by 1980. We must consider this figure as an outside limit, since an initial ILLIAC-IV 500 times faster than the 6600 represents a breakthrough as yet uncertain, its year of acquisition will depend on solution of future production problems, and there are of necessity even greater uncertainties about machinery following ILLIAC-IV.

Now, allow me to take an extreme tack, and to ask what we would do if computer speed were our only limitation. We would pile all of atmospheric physics possible into our models, and reduce the mesh size of our models as much as possible. In NWP, the latter introduces a curious fact, a fundamental relationship between computer speed and mesh size. In this connection, I will assume that current operational deadlines for predictions in various ranges must more or less be met.

Before discussing this in terms of the future, let me look at the past. What have we done with the 105-fold increase in computer speed given to us by advances in hardware technology to date, as shown in Figure 1?

We started operational production with a one-hour time step, 1000 points spaced 381 km apart in the horizontal, and a barotropic model with one level of resolution in the vertical. We were thus performing calculations at 1000 pts. every forecast hr. We now have 10-min. time-steps, 3000 points in the horizontal (covering a greater area with spacing the same as earlier), and six levels of resolution in the vertical. Every forecast hour we now perform calculations at  $6 \times 3000 \times 6 = 108,000$  points, a 108-fold increase. There are other differences among the models which affect running time, but they all tend to compensate each other. The point is that in the past, in a rough sense, we have used the 105-fold increase in computer speed to increase the number of points in space and time.

The atmosphere occupies all three space-dimensions, and our present numerical methods, for computational stability, require the time-step to be proportional to the distance between points in the horizontal. In itself, this means that the number of calculations increases as the fourth power of reduction in grid size. Where  $\Delta x$  is the grid size, and N is the number of calculations,

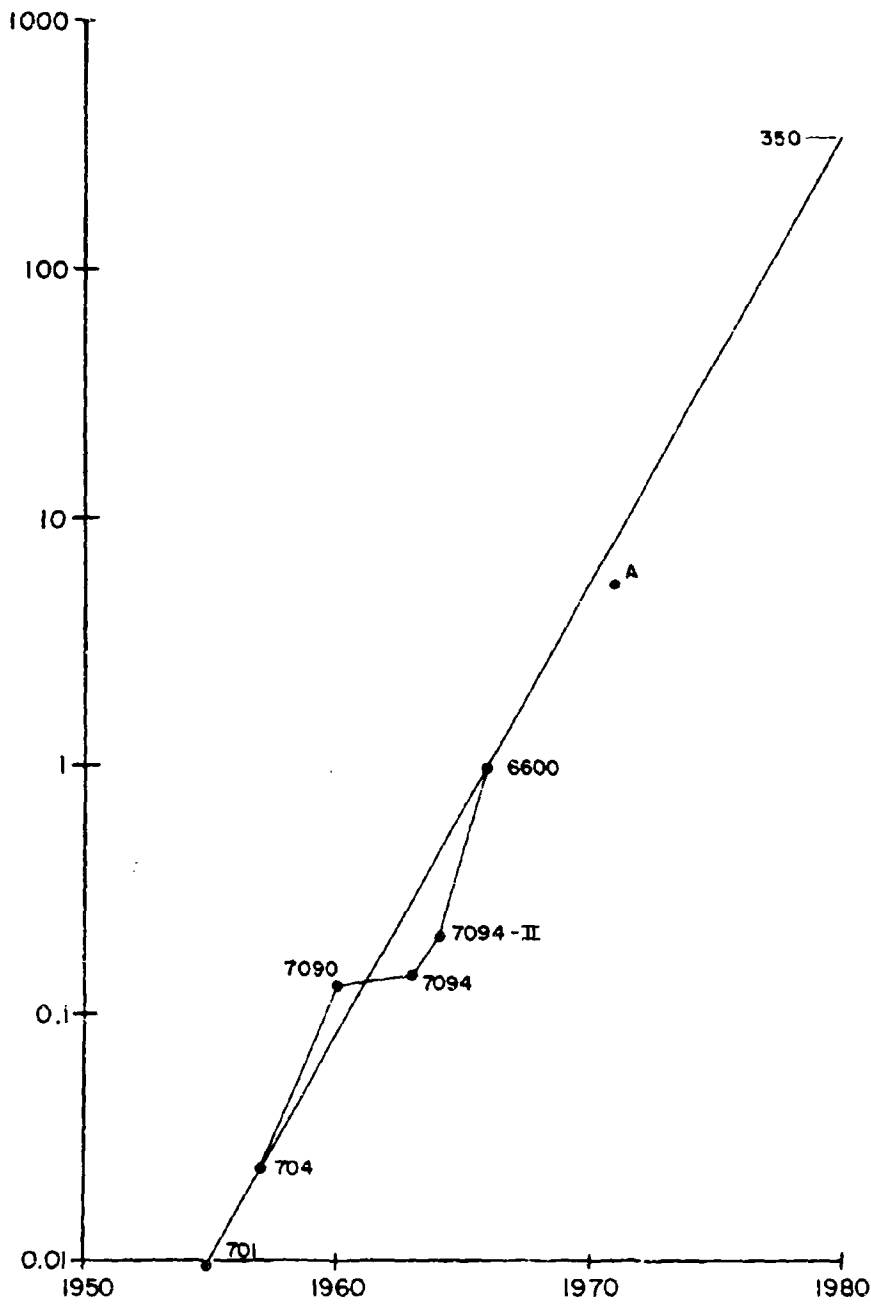

Figure 1

$$N \sim \frac{1}{(\Delta x)^4}$$

An increase in speed by 10,000 fold (the 1980 follow-on to ILLIAC-IV) would thus allow a reduction of grid-size by a factor of 10. As others have suggested, a reduction in horizontal grid size would probably not require as great a reduction in the vertical. On this basis, let's take

$$N = \frac{1}{(\Delta x)^{3.5}}$$

Then an increase in speed of 10,000-fold would permit a reduction of grid size by a factor of 14 instead of 10.

The table below shows permissible reduction factors for grid size for two conceivable 1980 computers, one with a 350-fold speed over the 6600, the other with 10,000-fold; and with the two power laws, 3.5 and 4.0.

	350-fold	10,000-fold
2.5-power	10.4	39.9
3.5-power	5.33	13.9
4.0-power	4.33	10

I have also included values for a 2.5-power law, the latter being in case we could somehow arrange to reduce the grid-size without affecting the time step. Implicit difference systems have such an attractive property, but invariably entail additional calculations per time step. We could at least hope to gain something from implicit systems, and the 2.5-power law figures are shown as values beyond reasonable limits.

We note here that vastly faster machinery will get us a reduction in grid size of a factor of only about 2 1/2 over the slower machinery. As someone has said, NWP in relation to computers may be likened to a gas in a container. No matter how much the container is expanded, the gas will fill all available space.

From this simple exercise, it can be seen that even our highest expectations in computer speed by 1980 will not allow operational treatment of a hemisphere in the convective cloud scale - which would require a grid-size 1,000 times smaller than the current size, and computers 3-million-fold faster than the projected 1980 follow-on to the ILLIAC-IV. With the growth rate of 53% compounded annually, such machinery would not appear until 2015 A. D. With great good fortune, my great-grandchildren will take part in the ensuing breakthrough.

If I may venture a prediction, by 1980 our operational global models will have horizontal spacing of 50 to 100 km and 10-15 levels in the vertical. Meanwhile, capabilities for short-range models over a limited area with considerably finer mesh will develop insofar as computer power is concerned. Observational capabilities for such models are highly doubtful, however.

### III. THE OBSERVATIONAL LIMITATION

Our current operational data base consists of :

- (1) 2000 surface observations,
- (2) 450 rawinsondes,
- (3) 1000 aircraft reports, and
- (4) satellite cloud photographs.

In the case of the first three, the numbers shown are of those processed per 12 hr cycle. Satellite cloud photographs cannot clearly be stated in the same quantitative terms. Their coverage is excellent, superior to the other three, but they are not accurate measurements of the quantities we need (3-dimensional distribution of pressure, temperature, wind velocity, and moisture).

With the exception of satellite cloud photographs, all of these sources come mostly from the northern half of the Northern Hemisphere (north of 30N). This quarter of the globe is about evenly divided between continent and ocean. Rawinsondes are confined almost entirely to the continental areas, aircraft reports to the oceanic areas, and surface reports more evenly divided.

The table below gives area per observation and its square root, which is the average spacing of the observations.

	Area per Observation	Average Spacing	
Surface Observations	$6.5 \times 10^4 \text{ km}^2$	250 km	Continents & Oceans
Rawins	$14 \times 10^4 \text{ km}^2$	380 km	Continents
Aircraft reports	$6.5 \times 10^4 \text{ km}^2$	250 km	Oceans

These figures can only be regarded as rough approximations because of the rough assumptions. They do, however, show a rough compatibility with the grid spacing, 236-408 km, of the operational model.

There are glaring deficiencies, on the other hand. Both aircraft reports and surface observations represent only one level of information in the vertical, and over oceans are unevenly distributed, being concentrated along commercial routes. And there is the problem of the southern 3/4 of the earth, where to the order of magnitude shown in the table, conventional observations are non-existent.

Now, what is in store for the 1970's? The single most certain source of additional data is indirect soundings from satellites. On May 20, 1969, NMC began operational use of such data, so-called SIRS, from Nimbus-3. The Nimbus is an experimental program, and so cannot be depended upon to be continuous, but it is already clear that an observational breakthrough has been achieved. While we await an operational program, we will use data from Nimbus experiments, as available, in our operational analyses and learn to make optimum use of them.

Figure 2 shows the schedule of pertinent space shots.

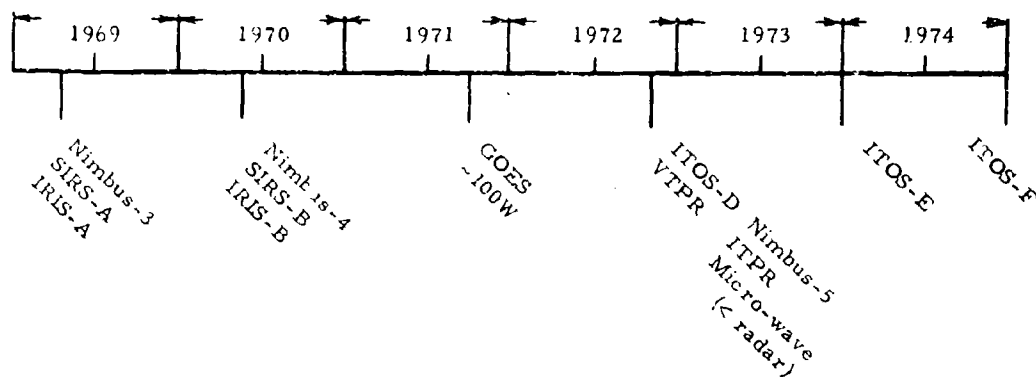

Figure 2

SIRS-A instrumentation has a field of view 200 km in diameter, in rough correspondence to the conventional net. There are large gaps in its coverage in low latitudes because it looks straight down, and successive passes are more than  $15^\circ$  of longitude apart. It gives information equivalent to about five independent temperatures in the vertical. IRIS-A may give operational information about the moisture field, but it is not available now.

SIRS-B aboard Nimbus-4 will be instrumented to scan laterally and will close the gaps in low latitudes. IRIS-B is an improvement over the "A" model and will give about three independent humidity measurements in the vertical.

GOES will be geostationary at 100W, and will give wind information through tracking of individual clouds. Investigations by NESG (National Environmental Satellite Center) show that such observations will be far more quantitative than any other current methods for determining winds from satellite platforms. They will contain, however, essentially only one level of information, although the level will vary widely by cloud type. They may not add much independent information to a SIRS-type data base in middle and high latitudes, but will be of great value in tropical regions, where SIRS-type data, being observations of mass and pressure, will not be of much use.

ITOS-D and Nimbus-5 will be shot at approximately the same time. ITOS-D will be the first operational satellite with indirect sounding equipment, and I will discuss it rather than the experimental Nimbus-5.

VTPR (Vertical Temperature Profile Sounder) aboard ITOS-D will have a narrower field of view, about 35 km, but will have wider channels. The narrower field of view will be used to look through breaks in clouds, and will not necessarily result in greater horizontal resolution of input to NWP. VTPR, like SIRS, will give about 5 independent temperatures in the vertical, but they will all be below 100 mb, where we mostly need the information. Only one level of information will be obtainable on humidity - precipitable water or equivalent information.

ITOS-E is a backup to "D", with essentially the same instrumentation. Its design is now committed.

The importance of ITOS-F, the backup to "E", is that its design is not now committed. We should ask for three levels of humidity observations.

The vertical resolution of indirect soundings from satellites is relatively fixed by fundamental problems. In order to increase the vertical resolution by 20%, the number of radiances observed would have to be doubled. The point of diminishing returns would therefore very quickly be reached.

Networks of constant pressure balloons would not change the observational picture in any fundamental way, although they could provide more accurate wind measurements than GOES. Such balloons would likely provide essentially only one level of wind information in the troposphere.

#### IV. CONCLUDING REMARKS

With fifteen years experience in operational NWP, we are perhaps in a better position to predict the 70's decade than we were in 1959 to predict the 60's. At least the framework of future operational global models seems clear.

By coincidence, projections of computer power and observational networks lead to similar conclusions. Growth in computer speed will allow a reduction in model grid size by about a factor of five, with roughly a doubling of levels in the vertical. The observational network spacing will not match this resolution, being off by a factor of two or three, but NWP models should have a finer mesh than the observational network to prevent accumulation of truncation error.

I have so far avoided discussing the range of future numerical weather predictions. The question of range involves limitations (3) and (4), gaps in scientific and mathematical knowledge, which I do not believe will be overriding in refining the model framework by increasing its resolution. With present knowledge, I expect improvement in the shorter ranges with such a refinement.

At least we know by trial that we have not reached a fundamental or useful limit of predictability at five days. We should reasonably expect extension of this range. During the 1960's we have extended the useful range of NWP by about a factor of three. Projection of this experience through the 1970's would lead to a useful range of a fortnight.

## THE REAL-DATA FORECAST PROJECT AT NCAR-A PROGRESS REPORT

David P. Baumhefner  
The National Center for Atmospheric Research  
Boulder, Colorado

An outline of the work on real-data forecasting accomplished during the past few years at the National Center for Atmospheric Research and its possible applications to future numerical weather prediction models is presented. Several basic questions, such as resolution, lack of data, initialization, and predictability is discussed and contrasted with the results of our real data forecast experiments. A brief summary of the current numerical models being used at NCAR is given. Two forecast experiments in which the initial moisture was varied considerably is shown to point out the effect of altering the initial data in the model. The difference between an unbalanced initial state and a balanced initial state is discussed, and the resolution problem is investigated with a two-layer model vs. a six-layer model comparison. Finally, the accuracy of our six-layer real-data forecast is examined in detail.

### I. Introduction

One of the major questions currently being asked with regard to numerical weather prediction concerns the ultimate limit of deterministic forecasting. Recent research performed by the Real-Data Forecasting Project at NCAR has attempted to answer this question along with other related problems. The long-range guidelines of the Real-Data Project include (1) the examination of the predictability or accuracy of the numerical models, (2) testing different variations of the model, and (3) preparation of a global forecasting model for the proposed Global Atmospheric Research Project (GARP) worldwide data. In order to carry out these guidelines, two global data sets are being constructed; a period of 5 days in January 1958 is nearing completion and a new case for the month of December 1967 has begun.

The contents of this report include a discussion of the various real-data forecasting models and their structure. Three experiments are presented in which the problems of initial data, initialization, and vertical resolution are brought into focus. And finally, the most accurate forecast to date made by our six-layer model is shown.

### II. Discussion of Models

The models being used to forecast real data are very similar to the G.C.M. formulated by Kasahara & Washington (1). The most distinguishing feature of this model, when compared to others, is the use of geometric height as the vertical coordinate instead of some function of pressure. The various physical processes included in the model are similar to those of Shuman (2) and Miyakoda (3).

There are three versions of the model in which the vertical and horizontal resolution vary. The original two-layer model, in which the vertical thickness is 6 km and the top is 12 km, has been expanded to include six layers, with a vertical thickness of 3 km and a top of 18 km. The horizontal mesh for these two models is  $5^{\circ}$  latitude x  $5^{\circ}$  longitude. A new code is currently being tested which will allow a variation in the horizontal grid spacing. The six-layer version includes a hydrological cycle and a non-linear viscosity coefficient. All three models now have the capability of simulating the effects of terrain by physically blocking the atmospheric flow in areas where the land mass intersects the vertical grid mesh.

INITIAL MOISTURE COMPARISON - 1.5 km MIXING RATIO

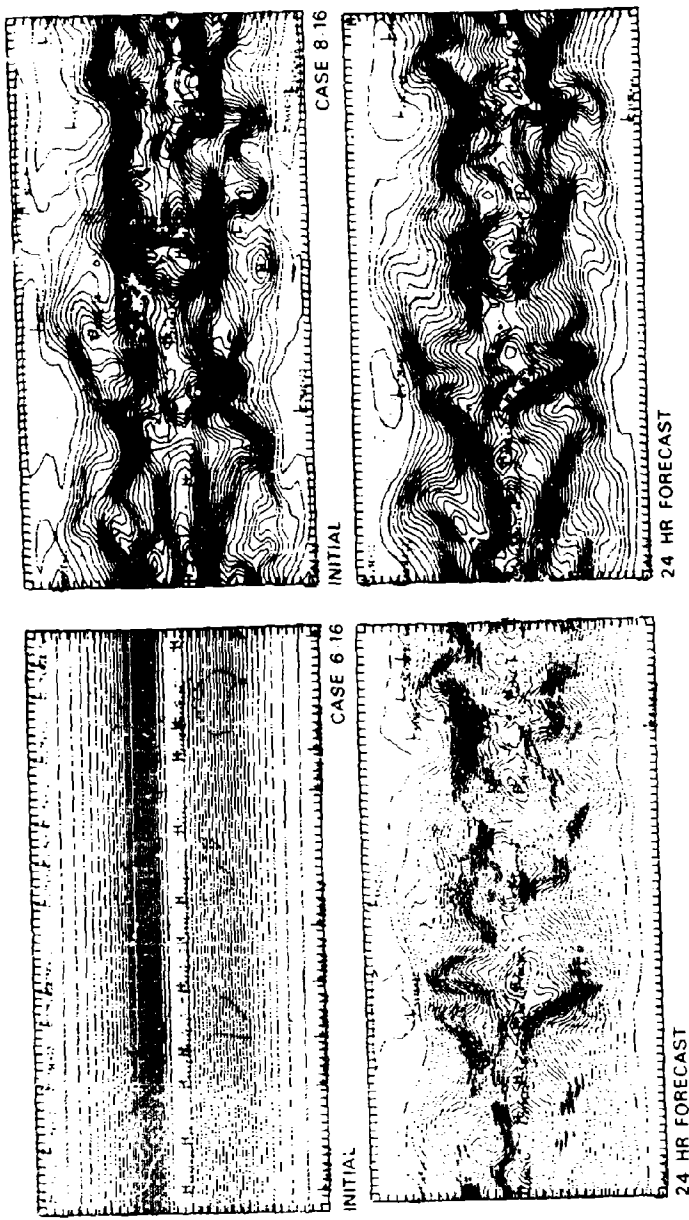
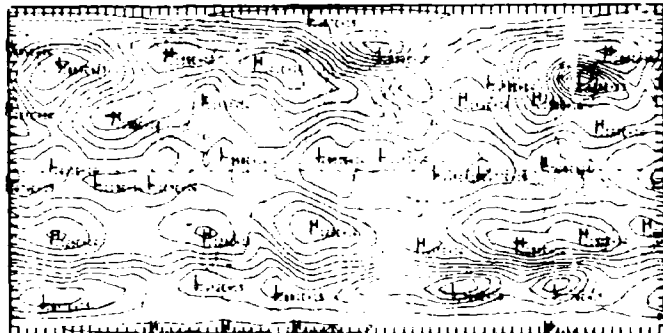

Figure 1



48 HR SFC FORECAST



LATITUDINAL MIXING RATIO CASE 6-16

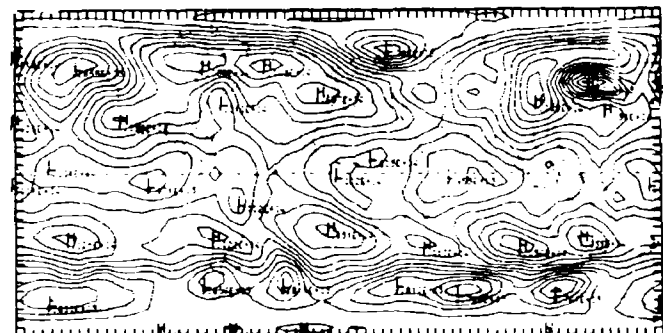

LATITUDINAL RELATIVE HUMIDITY CASE 8-16

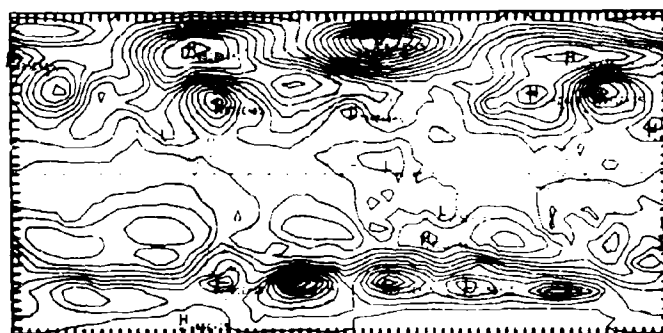

OBSERVED 17 JAN 58

	SKILL SCORES	
	S <sub>1</sub>	RMS
30.70 N	65.7	74.3
N. HEM	69.3	66.2
GLOBE	67.1	62.1

30.70 N	65.3	76.7
N. HEM	69.0	68.5
GLOBE	66.4	64.2

Figure 2

24 HR SFC FORECAST

S<sub>1</sub> SCORES

30 70 N 54.3  
 N HEM 58.8  
 GLOBE 58.5



BALANCE EQUATION

CASE 39

ROOT MEAN SQUARE ERROR

30 70 N 55.0  
 N HEM 48.0  
 GLOBE 43.9

30 70 N 64.8  
 N HEM 65.4  
 GLOBE 67.4



NO BALANCE

CASE 62

30 70 N 74.0  
 N HEM 64.6  
 GLOBE 58.4

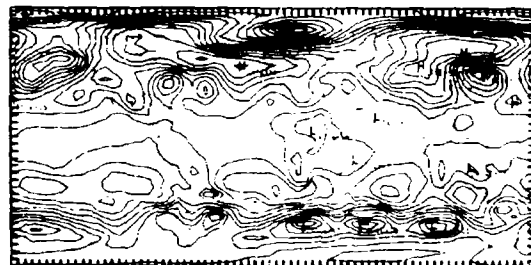

OBSERVED

16 JAN 58

Figure 3

24 HR 6 km FORECAST

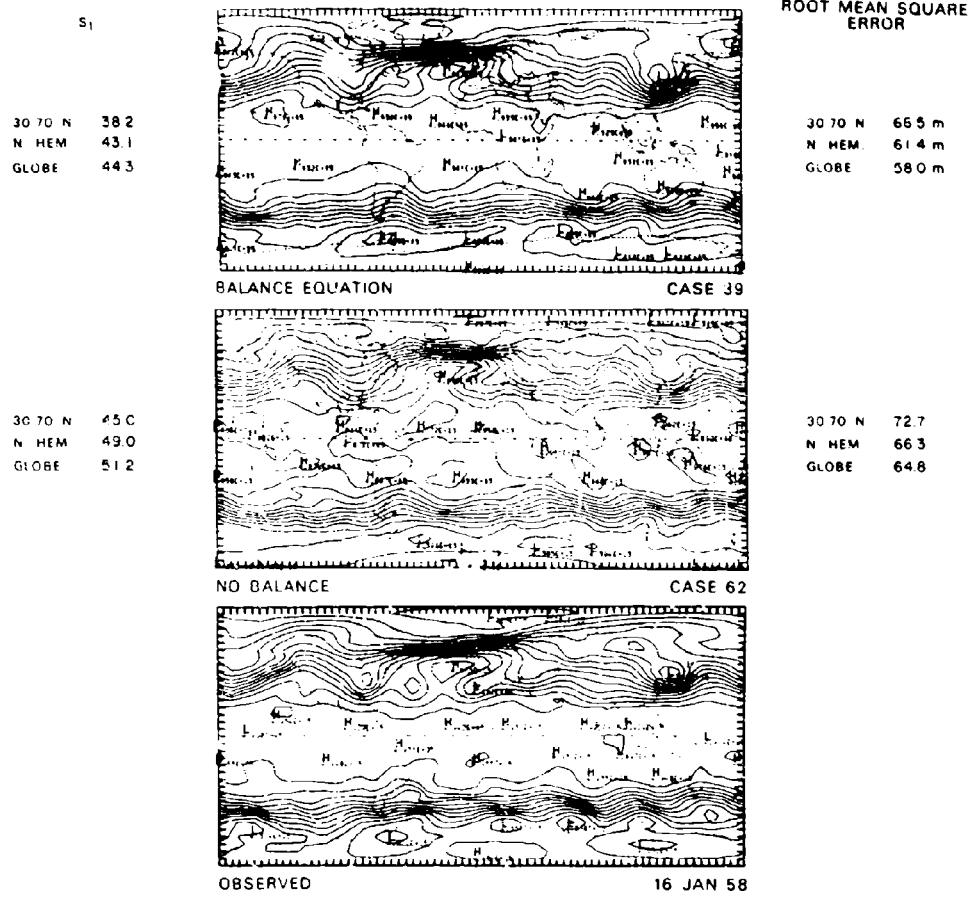

Figure 4

### III. Initial Data Variations

All numerical models require an accurate definition of the initial state of the atmosphere in order to produce a realistic forecast. However, it is unclear which atmospheric variables need to be observed accurately, or what their relative importance is in different geographical areas. Since the effect of moisture in the momentum equations is secondary in nature, it was decided to design an experiment to examine how an initial moisture variation will effect a forecast. Two 24-hour forecasts were made using our six-layer model, starting with two different initial moisture distributions (Fig. 1). The initial moisture for Case #6-16 is simply a zonal, climatological average of the mixing ratio for January. The mixing ratio for Case #8-16 is calculated from a zonal average of the relative humidity for January. Although the initial moisture distribution is quite different, the 24-hour forecast (Fig. 1) shows very similar patterns. Apparently, the moisture field conforms quickly to the large-scale flow patterns even if the initial conditions are somewhat independent.

Figure 2 illustrates the difference between the two initial moisture distributions as reflected in the surface pressure forecast. Judging from the two skill scores ( $S$  and RMS) and a visual examination of the surface pressure patterns, it is evident that very little change is made in the forecast by the different initial conditions. It appears from this experiment that the analysis of the initial moisture field will have little or no effect on the outcome of a forecast made from a relatively large-mesh model.

Several other experiments are in progress to check initial data variations. A semi-objective technique derived by Nagle (4) to modify the 500 mb height field using satellite data is being tested on data in the Southern Hemisphere. Another technique to extract wind data from ATS satellite observations is also being considered. These schemes will be used to check the effectiveness of the additional data by forecasting with and without the derived satellite information. Further work is in progress which will hopefully determine whether observed velocity or pressure is needed to produce the most accurate numerical prediction.

### IV. Initialization Experiments

Extensive comparisons among various initialization techniques have been presented by the author (5). The main conclusion drawn from these comparisons was the relatively small change in the overall accuracy of the various forecasts which were derived from different initialization schemes. One further experiment was performed in which an unbalanced or uninitialized velocity and pressure field was used as the initial condition. This experiment provides a basis for judging the merits of filtering the gravitational waves from the initial data. Two 24-hour surface forecasts derived from a two-layer model are shown in Fig. 3. Case #39 has been initialized with the complete balance equation and Case #62 starts with the unbalanced initial state. The gradients appear to be more intense in the unbalanced case, however, the balanced forecast contains less phase error. The skill scores indicate that the balanced case is clearly superior with almost a 10% improvement in accuracy. The same result is true for the 6 km forecast (Fig. 4), although the relative improvement is less. It is interesting to note that after three days the skill scores of both cases approach the same value at 6 km. Therefore, for longer range forecasts, it may not be necessary to initialize the observed data.

The result of the previous experiment is somewhat surprising and may be due in part to the particular model that was used. Further comparisons with the six-layer model are under way to substantiate the preliminary conclusion based on the two-layer model. Also, experiments are being planned to test different formulations similar to Miyakoda & Moyer (6) and compare those results with the current iterative schemes.

### V. Effects of Resolution

Perhaps the most severe limiting factor in the development of numerical models has been grid point resolution. The relative size and speed of the computer currently being used directly controls the amount of resolution that one may incorporate into a model. Therefore,

48 HR SFC FORECAST

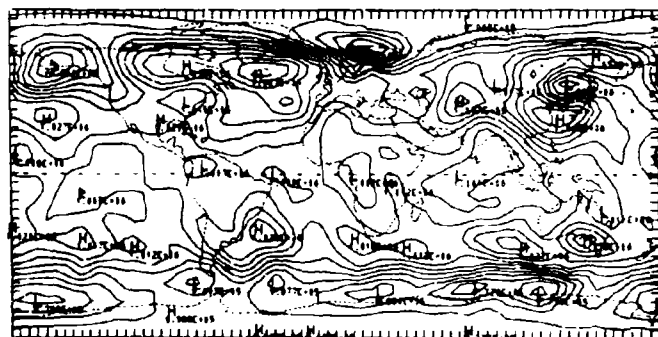

2-LAYER

CASE 38-127

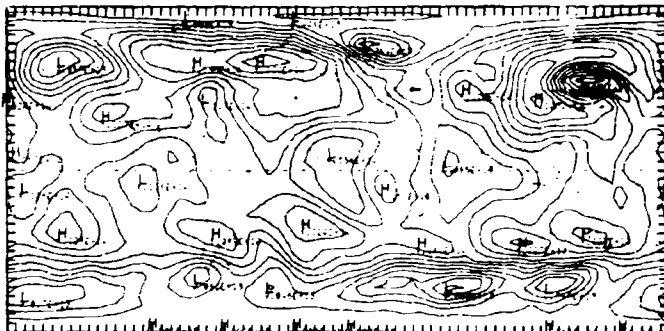

6-LAYER

CASE 2-16

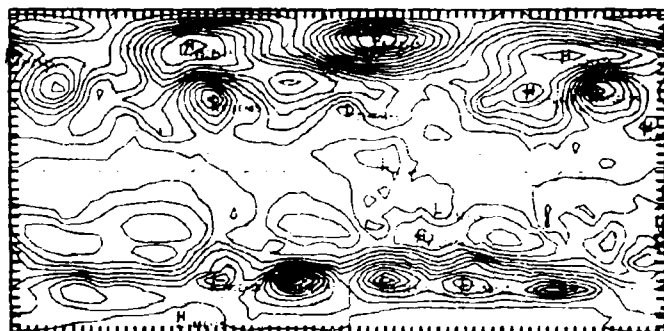

OBSERVED

17 JAN 58

	SKILL SCORES	
	S <sub>1</sub>	RMS
30-70 N	73.4	93.6
N. HEM.	74.7	78.1
GLOBE	73.9	70.8

30-70 N	70.0	81.7
N. HEM.	72.7	71.7
GLOBE	71.6	67.5

Figure 5

48 HR 6 km FORECAST

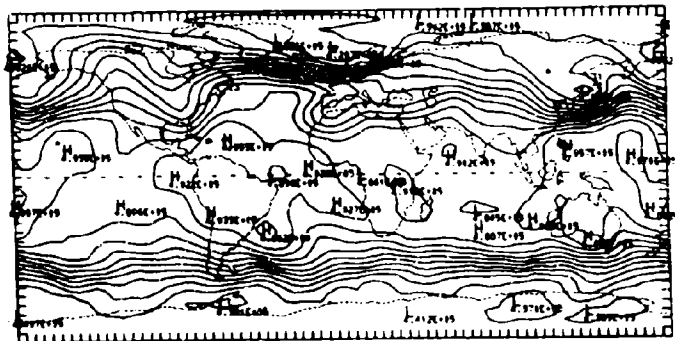

2-LAYER

CASE 38-127

SKILL SCORES  
S<sub>1</sub> RMS

30 70 N	49.8	88.5
N. HEM.	54.7	78.1
GLOBE	57.2	82.2

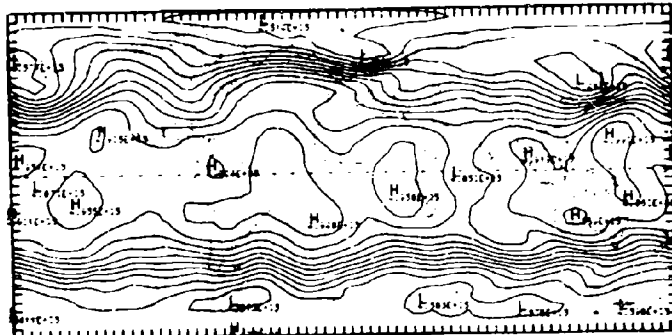

6-LAYER

CASE 2-16

30 70 N	45.8	76.7
N. HEM.	51.9	73.4
GLOBE	54.6	79.8

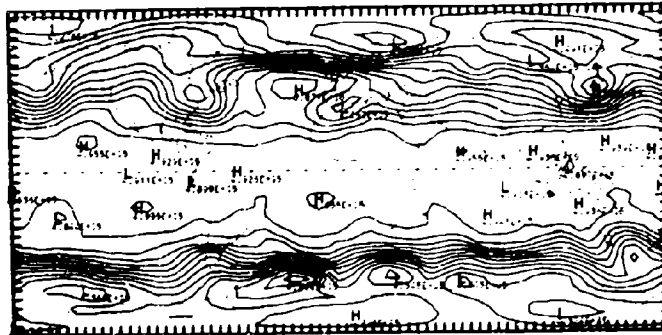

OBSERVED

17 JAN 58

Figure 6

SURFACE PRESSURE

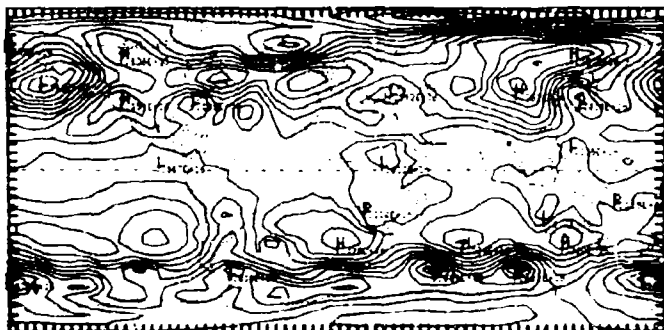

INITIAL

16 JAN 58

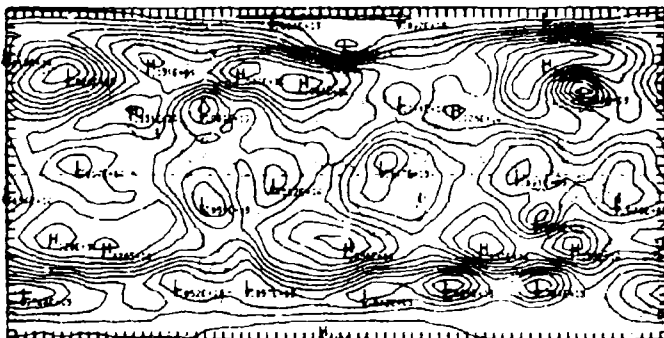

24 HR FORECAST

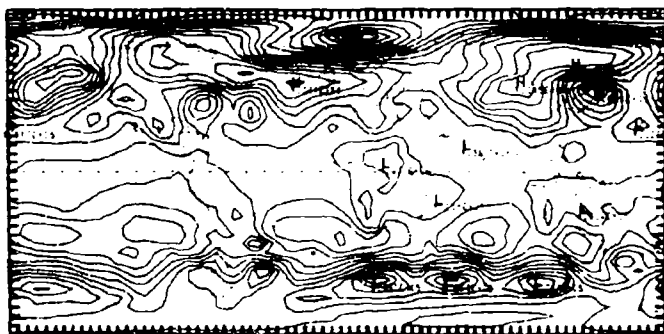

VERIFICATION

CASE 15-16			
SKILL SCORES			
	S <sub>1</sub>	RMSP	
N. AMER.	48.3	49.9	
30-70 N	52.5	52.4	
N. HEM.	58.1	51.9	
GLOBE	57.2	49.6	

Figure 7

SURFACE PRESSURE

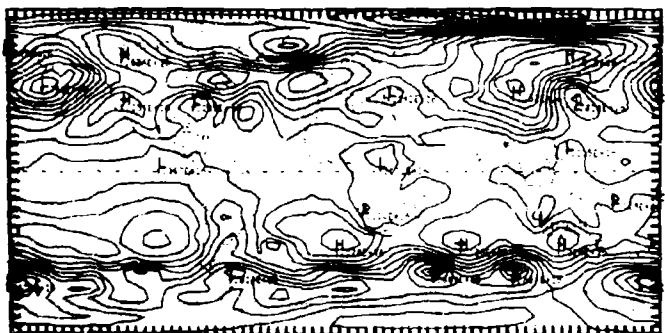

INITIAL

15 JAN 58

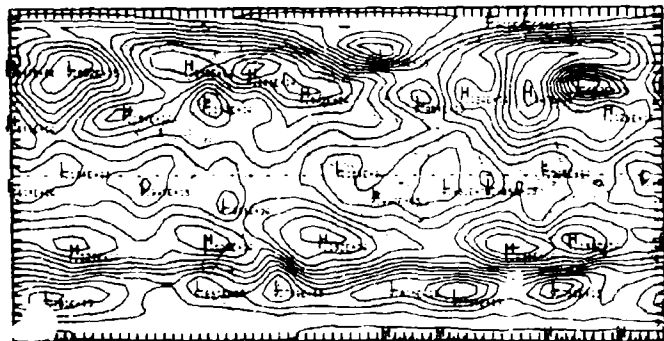

48 HR FORECAST

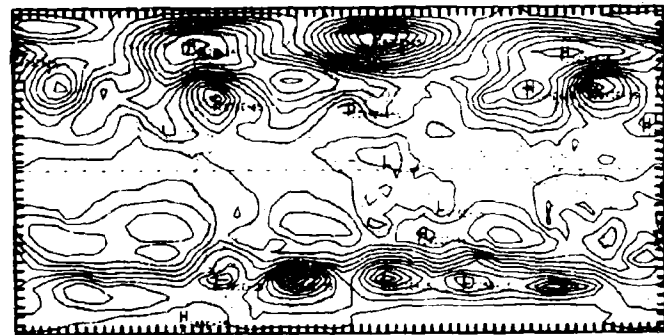

VERIFICATION

17 JAN 58

CASE 15-16

SKILL SCORES		
	S <sub>1</sub>	RMS
N AMER.	66.3	89.8
30 70 N	63.5	74.3
N. HEM.	67.2	67.3
GLOBE	65.4	64.0

Figure 8



6 km PRESSURE

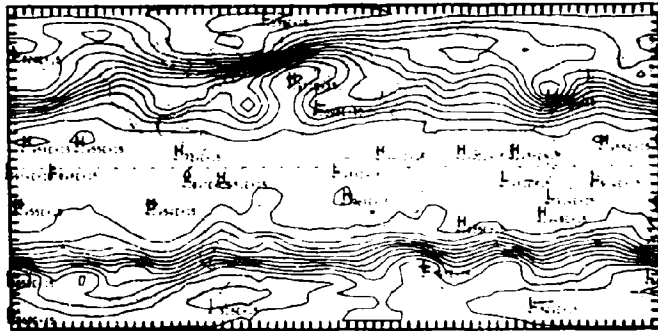

INITIAL

15 JAN 58

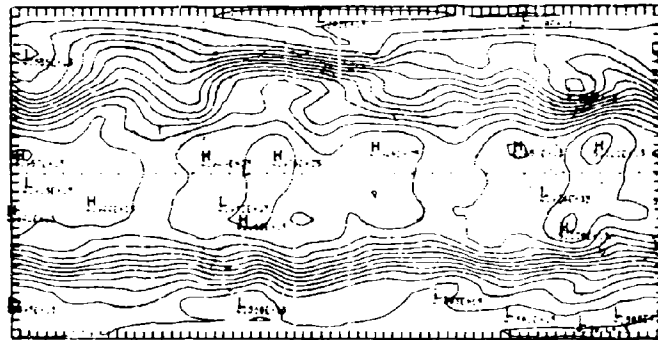

48 HR FORECAST

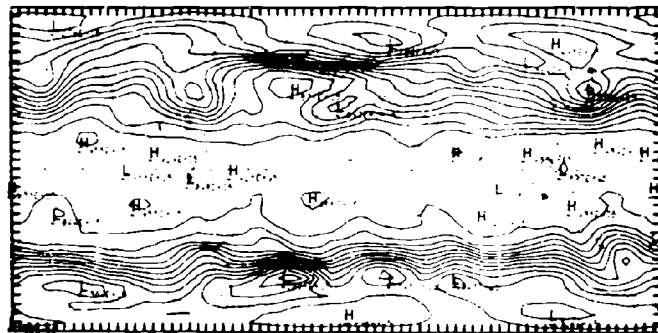

VERIFICATION

17 JAN 58

CASE 15-16

SKILL SCORES

	S <sub>1</sub>	RMS
N AMER	47.9	55.3
30.70 N	44.5	75.5
N HEM.	49.5	71.5
GLOBE	52.9	76.5

Figure 9

6 km PRESSURE

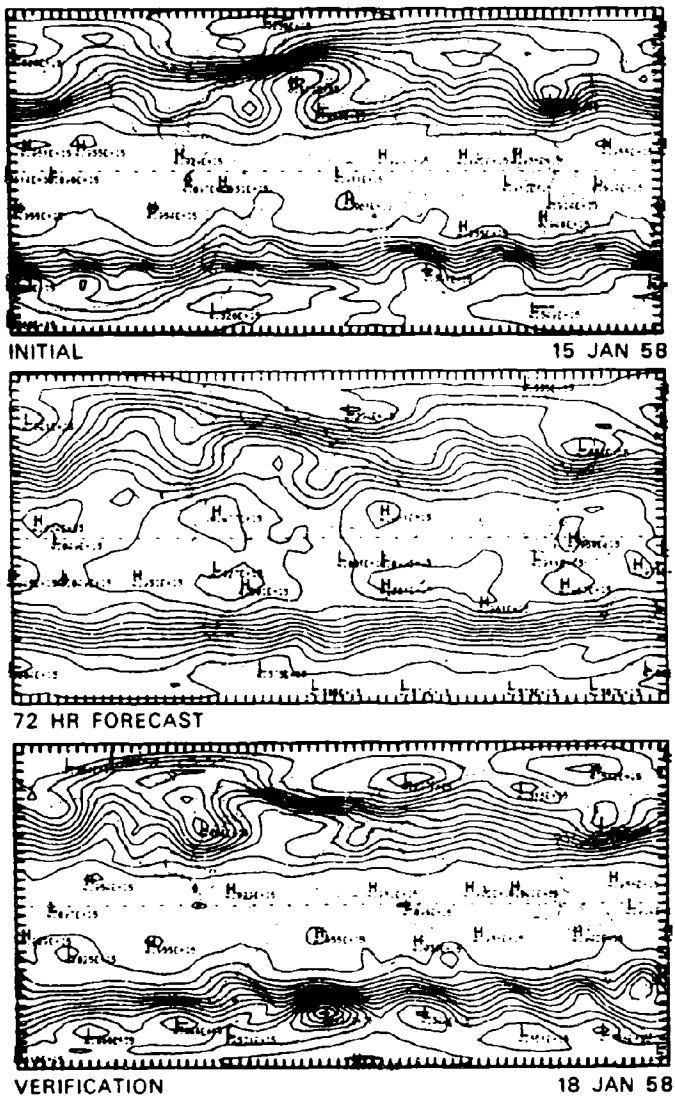

CASE 15-16		
SKILL SCORES		
	S <sub>1</sub>	RMS
N. AMER.	52.6	87.9
30 70 N	56.5	98.1
N. HEM.	58.8	82.9
GLOBE	61.1	85.2

Figure 10

resolution experiments are quite difficult to perform with a global prediction scheme. A preliminary attempt at examining the behavior of a global real-data forecast, when the vertical resolution was changed by a factor of two, is shown in Figs. 5-8. The internal characteristics of the two models (two-layer vs. six-layer) were exactly the same except for the resolution change. The two forecasts are adiabatic and begin from geostrophic initial conditions.

The 48-hour surface forecast (Fig. 5) illustrates a significant difference in forecasting skill. The phase error of the six-layer forecast is much less over the Eastern United States and other areas. The six-layer model shows an increase in intensity of all systems, which is exhibited in the improvement of the  $S_1$  score. The RMS score indicates an error reduction of nearly 10 m or 1 mb by increasing the vertical resolution a factor of two. Nearly the same increase in accuracy is achieved at 6 km (Fig. 6) where the improvement in the phase error is more noticeable. The six-layer model did not forecast a few areas as well as the two-layer model; the Algerian low and the trough on the E. Coast of South America portray this deficiency. However, the skill scores indicate an overall improvement with the six-layer model.

From the previous experiment, there was approximately a 5-10% increase in forecast accuracy achieved by a change in the vertical resolution. Further experiments are planned in order to determine the optimum vertical resolution for the global real-data forecast. Also, changes in the horizontal resolution will be attempted with a new version of the model now being coded.

#### VI. Accuracy of the Model Forecasts

Last year, a two-layer forecast was presented in which the "usefulness" or "skill" of the two-layer prediction was judged to be 24-48 hours at the surface and 72-96 hours at 6 km (5). Thus far, the most significant improvement in forecast accuracy has been the change to the six-layer model. Some of the physical processes, such as the hydrological cycle and the radiation calculation, have been greatly improved. Also, the Lax-Wendroff time step smoother has been eliminated. A sample forecast is shown in Figs. 7-10. All diabatic effects are included in the model with a saturation criteria of 75% relative humidity and the geostrophic initial condition is used for the wind field.

Figure 7 illustrates the 24-hour surface forecast along with the calculated pressure "skill" scores for certain geographical areas. Overall, the prediction looks very good with the positions of all major storms located correctly. Most of the intensifying systems were underforecast by 5-10 mb in the Northern Hemisphere and the central values of the low pressure in the Southern Hemisphere were missed by the same amount. The largest error is located just east of Greenland, where the pressure forecast was missed by 30 mb. However, the average pressure error for the 24-hour prediction was approximately 5 mb.

At 48 hours (Fig. 8), the truncation of the low pressure systems continues with an observed error reaching 15-20 mb and the average error approaching 7 mb. The forecasted central location of each major storm still agrees quite well with the verification pressure. The high pressure areas appear not to suffer from the weakening noted around the low pressure areas. The  $S_1$  score is near 65, which is still under the "no skill" level of 70 or greater (2).

In noting the 6 km level (Fig. 9), we see the gradients of the pressure field are also weakening. This phenomenon can be seen best in the very strong jet over the No. Atlantic, where nearly half the gradient has been truncated. The phase error of the major troughs in both hemispheres is still quite small at 48 hours. The 72-hour 6 km forecast (Fig. 10) begins to exhibit some rather large errors in the amplitude of the synoptic-scale troughs. These are most noticeable in the Eastern United States and So. Atlantic systems. The smaller-scale synoptic waves in the Southern Hemisphere have been lost in the truncation error of the  $5^\circ \times 5^\circ$  grid. The phase of the Northern Hemispheric storms is lagging in the observed field by  $10^\circ$  in most cases. Despite these deficiencies, the 72-hour forecast contains a fair amount of skill when the larger scale waves are examined. The root mean square error (~85 m) still has not reached the value obtained by assuming a persistence forecast.

CASE 15-16  
VERIFICATION

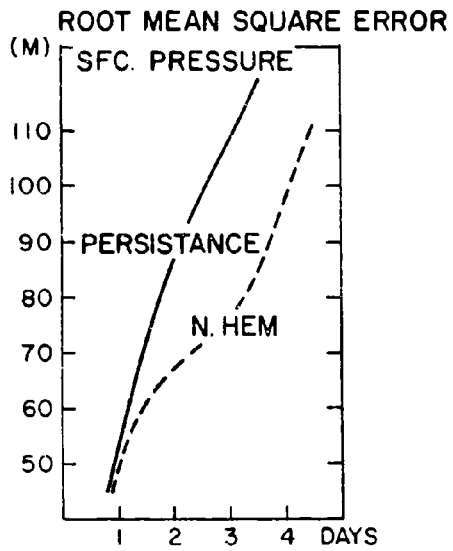
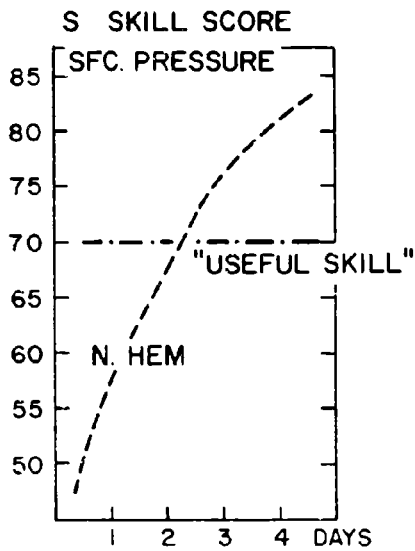
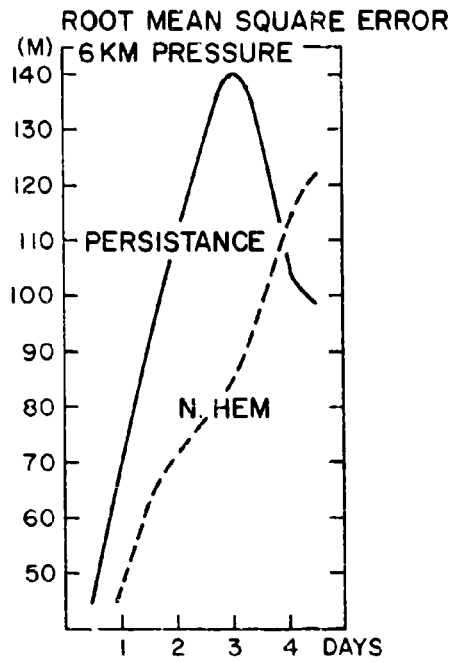
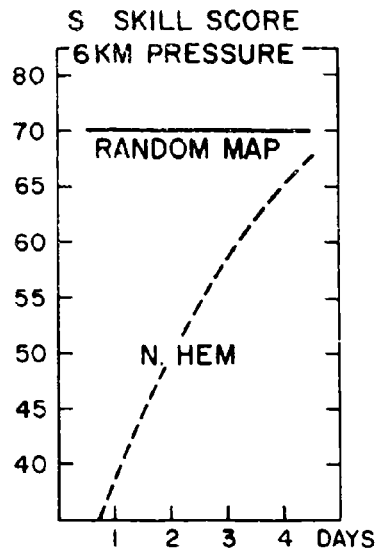

Figure 11

Four charts which attempt to show the relative usefulness or "skill" of the six-layer forecast are illustrated in Fig. 11. The two graphs on the right-hand side are the RMS of the forecast for the globe plotted with the persistence forecast error. If the crossover point between the two scores is to be used as an upper limit of the usefulness of the forecast, both levels have skill to four days. However, after examining the  $S_1$  graphs, it appears that this estimate may be too high. The arbitrary definition of 70, discussed by Shuman (2) was reached in 2.5 days for the surface forecast. After careful examination of the skill scores, the actual pressure difference maps, and the forecasts themselves, it was concluded that the surface had some skill to 72 hours and the 6 km level was useful to 96 hours. Of course, this judgment of skill is somewhat arbitrary and should be considered only a result of the synoptic-scale accuracy. However, if the longer wavelengths are singularly of interest, the relative skill of the forecast can be extended over a slightly longer period. The increased skill of the six-layer model represents approximately a 12-24 hour extension over the two-layer result.

### VII. Future of Real-Data Numerical Forecasting

It is possible, from the results of the experiments presented in this report, to speculate on the future of numerical weather prediction. These conclusions may be characterized as follows:

- (1) It is unclear how much effect additional data will have on the capability of the numerical models. It is the author's contention that it will ultimately depend on what resolution is being used in the model. It appears that the "secondary" variables do not need to be observed for the longer-range, large-scale forecasts.
- (2) From the extensive comparisons of different initialization schemes to date, only small changes in the accuracy of the forecast were achieved. For long-range prediction, it may not be necessary to initialize the data.
- (3) Judging from the results of the two vs. six-layer experiment, resolution is probably the biggest single factor which will improve the skill of real-data forecasts. A study by Grammelvedt (7) indicates that at least 10 grid points per wave length are needed for long-range prediction. Therefore, at least a  $1^\circ$  mesh will be necessary for an accurate forecast of the synoptic scale.
- (4) A reasonably accurate one-week forecast of the synoptic scale with the present numerical models is possible with good resolution and uniform initial data. A somewhat longer forecast may be realized if only the longer waves (e.g. wave #1-4) are considered.

### REFERENCES

- (1) "NCAR Global General Circulation Model of the Atmosphere," A. Kasahara and W. Washington, Monthly Weather Review, Vol. 95, No. 7, July 1967.
- (2) "Operational Six-Layer Primitive Equation Model," F. G. Shuman and J. B. Hovermale, Journal of Applied Meteorology, Vol. 7, No. 4, August 1968.
- (3) "Experimental Extended Predictions with a Nine-Level Hemispheric Model," Miyakoda, K. et al., Monthly Weather Review, Vol. 97, No. 1, January 1969.
- (4) "Approach to the SINAP Problem: A Quasi-Objective Method of Incorporating Meteorological Satellite Information in Numerical Weather Analysis," R. E. Nagle and J. R. Clark; Final Report, Contract #E-93-67(H) for Met. Satellite Lab., May 1968.
- (5) "Global Real-Data Forecasts with the NCAR Two-Layer General Circulation Model," D. P. Baumhefner, NCAR Manuscript #69-92, June 1969, to be published in Monthly Weather Review.
- (6) "Method of Initialization for Dynamical Weather Forecasting," K. Miyakoda and R. Moyer, Tellus, Vol. 20, No. 1, 1968.
- (7) "A Survey of Finite Difference Schemes for the Primitive Equations for a Barotropic Fluid," A. Grammelvedt, Monthly Weather Review, Vol. 97, No. 5, May 1969.

## PROGRESS REPORT ON ATMOSPHERIC PREDICTABILITY

Edward N. Lorenz  
Massachusetts Institute of Technology

The accuracy with which weather forecasts can ultimately be produced depends upon the natural amplification rate of errors. By "errors" we mean differences between arbitrary separate states of the atmosphere, or between separate solutions of the governing equations. Recent independent estimates by dynamical and empirical procedures agree that small errors in the synoptic and larger scales will double in about three days, growing more slowly as they become larger.

The greatest uncertainty in estimating the ultimate accuracy of forecasting arises from the possibility that the inevitable errors in the meso- or micro-scales will rapidly induce appreciable errors in the synoptic scale, which will then amplify as if they had been present initially. Preliminary studies support this hypothesis. Further studies using more refined statistical assumptions should be performed. Experimental numerical forecasts with very closely spaced grid points should be undertaken when sufficiently powerful computers become available.

### I. Introduction

Weather lore seems to date back to the earliest days of recorded history, but it is hardly more than a hundred years since the various nations began to establish national weather services, charged with the collection and dissemination of weather information. The earliest forecasts were necessarily rather unreliable, based as they were upon meager collections of observations and unsystematic prediction techniques, and they did not always gain public confidence. Indeed, Admiral FitzRoy of the British Navy was severely criticized by some of his scientific colleagues for issuing any forecasts at all to the public, and, following his death a few years later, the publication of the forecasts was discontinued.

During the past century the nations have continually expanded their networks of observing stations, so that a fair portion of the earth's surface is now covered. Perhaps equally important, routine observations now extend throughout the troposphere and well into the stratosphere, whose existence, incidentally, was unknown a century ago. Exchange of information, essential to the success of operational weather forecasting, has generally taken place even among those nations which have been disinclined to cooperate in other matters.

Likewise, new techniques of prediction have continually been introduced and tested. The improvements in weather forecasting which we have experienced over a hundred years can presumably be directly attributed to better observations or better techniques.

It is no secret, however, that many innovations in forecasting have failed to yield the improvements which were anticipated when they were introduced. A familiar example is isentropic analysis, whose developers, incidentally, visualized it as a research tool rather than a forecasting tool. Evidence of widespread belief, however, that isentropic analysis was at least the partial answer to the forecasting problem is the fact that some twenty-five years ago the pressure, specific humidity, stream function, and shear-stability ratio vector at each of three standard isentropic surfaces were mandatory information on every radiosonde message. Yet today how many forecasters even know what a shear-stability ratio vector is?

A notable exception to the rule that new techniques fail to produce appreciable improvements seems to be numerical weather prediction. We do not propose to present any documentation as to how well the technique has worked, but it seems safe to say that many meteorologists do not merely believe that numerical prediction is capable of yielding major improvements; they believe that these improvements have already been attained.

Nevertheless, in the first few years after numerical prediction was introduced as an operational technique, it was not at all obvious that real improvements would be forthcoming. Possibly it was the repeated failure of new methods to live up to expectations which from time to time led some meteorologists to ask whether there might be previously unsuspected limitations upon the possible accuracy of weather forecasting. In the past fifteen years or so, the subject of predictability has developed into a recognized field of meteorological research. The basic questions to be answered are, first, "What are the intrinsic limitations upon the extent to which the weather may be predicted?", and, second, "What further practical limitations are imposed by economic and other considerations?"

## II. Accumulation and amplification

We begin with the premise that if we knew the current state of the atmosphere and its environment exactly, and if we possessed an exact procedure for forward extrapolation of the state of the atmosphere and its environment, we could predict the future weather at any range without error. This premise is of course not strictly justified, since there is some indeterminacy in the evolution of the weather. In particular, the weather is influenced to some extent by unpredictable human activity. However, in the present discussion the lack of determinacy may be disregarded.

We then conclude that errors in prediction must result from imperfect observations of the state of the atmosphere and its environment, or imperfect techniques of forecasting. In further detail, let us consider a forecast of the behavior of the atmosphere throughout some interval of time. At any moment during this interval, the forecast will contain a specific error. We then find that any subsequent growth of the error must result from one or both of two processes: (1) an accumulation of further error due to a faulty prediction technique, and (2) an amplification of the existing error due to a basic instability. We shall refer to these processes as the accumulation process and the amplification process.

Symbolically, we may let  $X_1(t)$  denote the exact state of the atmosphere at time  $t$ , while  $X_2(t)$  denotes the predicted state; the error in prediction is then  $X_2 - X_1$ . If one were to predict the state at an extremely short range, say a few seconds, he could do little better than choosing the current state as it is believed to exist; thus, the limit of the error in prediction, as the range approaches zero, is simply the error of observation, and it is logical to regard the prediction error at zero range, as being the observational error.

We may also let

$$dX/dt = F(X,t)$$

denote the exact equation governing the atmosphere, while

$$dX/dt = G(X,t)$$

denotes the equation which would govern the atmosphere if the atmosphere really evolved in accordance with the prediction technique being used. It matters not whether the technique itself is numerical or subjective. We then find that the evolution of the error is given by

$$d(X_2 - X_1)/dt = [G(X_2,t) - F(X_2,t)] + [F(X_2,t) - F(X_1,t)]$$

The two bracketed terms represent the effects of the accumulation process and the amplification process.

Although a given technique gives better results in some weather situations than in others, there is no reason to anticipate any continual increase in the magnitude of the first bracketed term, which depends only upon the extent to which  $G$  fails to duplicate  $F$ . The term may oscillate about some average value. Thus we may expect that any increase in the total error

due solely to accumulation would be quasi-linear. On the other hand, the second bracketed term depends upon the extent to which  $X_2$  fails to equal  $X_1$ , i.e., upon the existing error, and may be expected to be large when the error is large. Thus the increase in the total error resulting from amplification may be quasi-exponential. If there is indeed an exponential growth rather than an exponential decay, the phenomenon we are witnessing is instability; two slightly differing states of the atmosphere, governed by the same physical laws, are evolving into considerably different states.

A further complicating factor is that once  $X_2$  no longer resembles  $X_1$  closely, i.e., once the error is moderately large, the growth of the error should no longer be exponential. Mathematically the nonlinear processes will have become dominant. In the limiting case where  $X_2$  and  $X_1$  differ as greatly as randomly chosen states of the atmosphere, no further systematic growth should be expected.

If  $G$  does not closely resemble  $F$ , i.e., if the forecasting technique is poor, an exponential phase of growth may not be observed at all. If, for example,  $G \equiv 0$ , so that the forecast is a simple persistence forecast, the growth of the error will certainly not be exponential. If, on the other hand, the forecasting technique is rather good, so that  $G$  and  $F$  are nearly the same, and if the observations are rather good, so that  $X_2$  and  $X_1$  are nearly the same initially, then, if the atmosphere is unstable, we may expect a range of time during which the amplification process will dominate, and a quasi-exponential growth rate will be observed.

Perhaps because it is hoped that the technique of forecasting will eventually become highly refined, and perhaps merely because of personal preference, many investigators seem to have concentrated their attention upon the process of amplification, i.e., upon the growth which already existing errors would undergo if the forecasting technique were perfect. In the remainder of this discussion we shall consider only the amplification process. We shall find that the topic breaks up into two related but distinct problems.

### III. Amplification of large-scale errors

The first problem concerns the amplification of errors which are present in the larger scales of motion. At a range of a day or more, it is only these scales whose details we usually attempt to predict. We may wish to predict that smaller-scale disturbances such as thunderstorms will occur tomorrow, but, except where local geography exerts a controlling influence, we do not try to predict the path of a particular thunderstorm.

In many meteorological undertakings, and in particular in numerical weather prediction, we effectively define the state of the atmosphere in terms of those scales large enough to be resolved by conventional networks of stations, or conventional geographical grids of points, separated by perhaps several hundred kilometers. Small scales of motion are acknowledged, but their statistical properties are assumed to be determined by the larger scales of motion to which they are superposed. The effects of the small scales upon the large scales are assumed to be expressible in terms of coefficients of turbulent viscosity and turbulent conductivity.

Most studies of the amplification process have implicitly accepted these assumptions. The problem then becomes fairly well defined. The atmosphere becomes for practical purposes a finite system, with the field of each meteorological variable expressible as a terminating series of standard functions, possibly spherical harmonics. A field of small-amplitude errors becomes governed approximately by a finite system of linear equations, derivable from the equations governing the atmosphere itself. An arbitrary field of errors is resolvable into a set of normal modes, or eigenfunctions (which in turn are linear combinations of the original spherical harmonics), each mode growing or decaying at its characteristic rate. The most rapidly growing mode eventually surpasses all the others in amplitude, so that its growth rate becomes the ultimate growth rate of small errors.

In practice it is not feasible to find the various normal modes. Most studies of the growth rate of small errors do not attempt to derive systems of equations governing the errors, but proceed to solve numerically one approximate form or another of the equations governing the atmosphere - usually a system which has already been derived for studying



the general atmospheric circulation. Two time-dependent solutions with slightly differing initial conditions are found. It is then a simple matter to determine how rapidly the difference between the solutions, i.e., the error, has grown.

We cite the most recently documented and probably the most detailed study of this sort, performed by Smagorinsky (1969). In his two initial states the temperature fields possessed a root-mean-square difference of one-half degree. After a brief adjustment period, when much of the initial error in the temperature field seemed to be transferred to the wind field, there was fairly rapid growth, with a doubling time of about three days. The growth rate subsided as the error increased, until, by the time the error acquired more than half of its limiting root-mean-square amplitude of five degrees, the doubling time reached about ten days.

Like all other studies of this sort, Smagorinsky's depends upon an assumed form of the equations governing the atmosphere. It would be desirable to have some results which do not suffer this restriction. We have recently completed such a study (Lorenz 1969a).

This study is based entirely upon observational data, and makes use of the concept of analogues. By analogues we mean two states of the atmosphere occurring at widely separated times but bearing considerable resemblance to one another. If two states qualify as good analogues, either state may be regarded as equivalent to the other state, plus a small error. By observing the behavior of the atmosphere following the occurrences of each state, we may determine how rapidly the error has grown.

In the five years of data which we processed, we were unable to find any truly good analogues. The smallest root-mean-square height-field errors which we encountered, which were more than half as large as differences between randomly chosen states, tended to double in about eight days. There was a strong relation between the size of an error and its growth rate, the smallest errors growing most rapidly. Extrapolation by the most easily justified simple formula indicated that very small errors would double in about 2.5 days.

Smagorinsky's dynamical study and our empirical study therefore show remarkably good if not perfect agreement. They give a rather consistent picture of the expected future progress of an error which is initially small. To translate the results into possible ranges of prediction, we must have some idea of the accuracy and completeness with which the atmosphere will some day be observed. We can present no reliable figures; however, useful forecasts of the positions and intensities of migratory cyclones and anticyclones ten days or even two weeks ahead might well be anticipated within a generation, whereas similar forecasts a month ahead seem entirely unrealistic.

#### IV. Influence of small-scale errors

The second problem concerns the possibility that errors which are present in the smaller scales of motion may lead at a later time to errors in the larger scales. Strictly speaking the complete state of the atmosphere includes not only the larger scales as seen on standard weather maps, but also the locations and structures of thunderstorms and indeed of the smallest turbulent eddies. Since we do not observe the finer details of thunderstorms and smaller systems, our observed state of the atmosphere must contain errors in the small scales.

These errors should amplify much more rapidly than the larger-scale errors; an error in observing a thunderstorm, for example, should grow at least as rapidly as the thunderstorm itself. At the same time, it may under suitable conditions progress to larger scales. Stated otherwise, two states of the atmosphere which are initially identical in the larger scales, and in the statistics but not in the details of the smaller scales, may evolve differently. Stated again, a slight alteration in the arrangement of the smaller scales of motion may alter the course which the whole atmosphere will follow.

Consider first a sky filled with small fair-weather cumulus clouds. These may be of rather uniform size and shape, and rather uniformly spaced. There are no towering clouds within their midst. Under these conditions it is hard to visualize how a simple reshuffling of the clouds, placing them in different individual locations, could have an appreciable influence upon the ultimate behavior of the air mass in which they are embedded.

On the other hand, consider a large number of small cumulus clouds accompanied by a fair number of towering cumuli and a few giant cumulonimbi; the latter may, in turn, be organized into a squall line. In this event the relocation of a few small cumuli might easily alter the behavior of a nearby larger cumulus; this might in turn affect the growth of a cumulonimbus, which could then alter the course of the squall line and finally the whole air mass. The eventual contamination of a forecast by a progression of the error from small to slightly larger and thence to still larger scales therefore looms as a possibility.

In a recent theoretical study (Lorenz 1969b), we have attempted to investigate this possibility quantitatively. We have derived a system of equations whose dependent variables are the mean-square velocity errors in the various scales of motion. For convenience we have allowed each scale to cover an octave of the spectrum. For initial conditions we assumed that systems of diameter greater than 40 meters were perfectly observed, while systems of smaller diameter were unobserved. We found that the errors did indeed propagate to larger scales.

Specifically, the errors in one scale induced errors mainly in the next largest scale; these in turn induced errors in the next scale, etc. By the end of an hour, the initial errors in the 20-40 meter scale had propagated to the cumulus scales (1-10 kilometers). After a day they had invaded the synoptic scales (1250-5000 kilometers). By 17 days there was little predictability left in any scale.

Actually, the error growth after the first day, when only the larger scales retained appreciable predictability, was very much as it would have been if no small-scale motion had been present at all. The principal difference between the results of this study and those of earlier studies is that the presence of smaller scales assured us that within one day there would be errors of moderate size in the larger scales. Without the small-scale motions, the errors in the larger scales at the end of one day would have been only slightly larger than the errors of observation.

These conclusions have such an important bearing upon the future of forecasting that we must quickly emphasize that, like most theoretical conclusions, they are based upon a number of assumptions, and, in this case, assumptions which may not be justified. Indeed, the conclusions are considerably more pessimistic than those which other assumptions would have yielded. Of primary importance is the assumption that the atmosphere possesses all scales of motion in abundance. Specifically, the energy per unit wave number is assumed to fall off from a peak in the larger synoptic scales according to a  $-5/3$  power law.

It is evident that if certain intermediate scales are actually more or less absent in the atmosphere, i.e., if there is a decided "spectral gap", the inevitable errors in the smaller scales can only induce errors in the larger scales by jumping the gap. This they can do only with difficulty, since the strongest influence of errors in one scale is upon errors in scales only slightly larger. In any event, jumping the gap requires considerable time, so that a gap would increase the range of predictability. Moreover, even without a gap, the progression of errors to larger scales is slower if the energy falls off more rapidly with increasing wave number, and it appears to be extremely slow if the energy follows a  $-3$  power law.

A further shortcoming of our study is the assumption that quadratic functions of the field of errors are independent of quadratic functions of the field of motion upon which the errors are superposed. This assumption could not remain valid over a period of time if, for example, errors grow most rapidly when superposed upon the most intense fields of motion.

#### V. The future outlook

It is apparent, then, that we cannot yet say how far into the future we may ultimately predict the weather, but it is equally apparent that we know where to proceed in order to advance our knowledge. For one thing, we need a mathematical model with more realistic statistical assumptions than those so far used. Steps in this direction have already been taken by Kraichnan (1969). Qualitatively, at least, his results seem to confirm those based upon the simpler assumptions.

Perhaps our greatest immediate need is for a more definitive estimate of the spectrum of atmospheric energy. The often-quoted spectrum of Van der Hoven (1957) shows a pronounced spectral gap, but it is a time-spectrum rather than a space-spectrum, and it is based only upon observations in the lowest hundred meters. Observations which would yield the high-frequency end of the spectrum in the free atmosphere do not yet seem to be sufficiently abundant.

A number of recent studies (e.g., Wiin-Nielsen 1967) suggest that from a peak at a wave length of perhaps 5000 kilometers, the energy spectrum falls off at a rate close to the  $-3$  power law, at least down to 2000 kilometers or less. Such a drop-off cannot continue indefinitely, since there would then be virtually no cumulus activity; however, assignment of a reasonable amount of energy to the cumulus scales produces a spectral gap. Thus the contamination of the forecast by errors initially confined to the smaller scales may well require considerably longer than the time indicated in our theoretical study. Pending further confirmation, we may still visualize the day when the positions of migratory cyclones and anticyclones may be predicted ten days or so in advance, rather than the four or five days which our study has suggested.

It has often been stated that one could in principle study the effects of the smaller scales of motion numerically, simply by using such an enormous network of points that the smaller scales would be resolved. It is generally added that such a procedure would require a prohibitive amount of computation, and would, furthermore, be ridiculously wasteful, because only the statistical properties of the smaller scales are of true interest. Be that as it may, I should like to see a numerical experiment performed, at least in two dimensions, with an enormous network of points. Perhaps we shall never see a grid of a million by a million points, but a thousand by a thousand should be easily handled within a few years. The procedure could be identical to the one which Lilly (1968) has already carried out with a 64 by 64 grid. A few runs with slightly differing initial conditions would suffice. I believe that such an experiment would not only be helpful in establishing the validity, or invalidity, of some of the statistical assumptions appearing in current studies, but that it might well reveal some unexpected new properties of the growth of errors.

#### REFERENCES

- Kraichnan, R.H., 1969: Instability in fully developed turbulence. Phys. Fluids, 12 (in press).
- Lilly, D.K., 1968: Numerical simulation of two-dimensional turbulence. NCAR Manuscript 68-234 (unpublished).
- Lorenz, E.N., 1969a: Atmospheric predictability as revealed by naturally occurring analogues. J. Atmos. Sci., 26 (in press).
- Lorenz, E.N., 1969b: The predictability of a flow which possesses many scales of motion. Tellus, 21 (in press).
- Smagorinsky, J., 1969: Problems and promises of deterministic extended range forecasting. Bull. Amer. Meteor. Soc., 50, 286-311.
- Van der Hoven, I., 1957: Power spectrum of horizontal wind speed in the frequency range from 0.0007 to 900 cycles per hour. J. Meteor., 14, 160-164.
- Wiin-Nielsen, A., 1967: On the annual variation and spectral distribution of atmospheric energy. Tellus, 19, 540-559.

## THE COMPUTER'S ROLE IN WEATHER FORECASTING

William H. Klein  
Techniques Development Laboratory  
Weather Bureau, ESSA  
Silver Spring, Maryland

### ABSTRACT

The history, present status, and future prospects of computer weather prediction by means of both numerical and statistical methods are discussed. Three statistical techniques - the classical, perfect prog, and imperfect prog methods - are illustrated, and a suggestion for combining them is made. The first method is purely statistical since it flows directly from initial conditions to a forecast for some later time. The second method derives the weather as a function of the concurrent circulation, but applies its forecast relations to numerical prognostic charts which simulate the observed circulation. The third method goes directly from the numerical forecast to the predicted weather.

A distinction is drawn between computer forecasting at a large weather center and a small field office. At the former, the concept of the man-machine mix is expected to be replaced by complete automation by the end of the 1970's. At the latter, computer data links and time sharing should become increasingly important as forecaster aids during the next two decades.

### I. Introduction

The role of the electronic computer in weather forecasting is undergoing rapid evolution. Perhaps its future can best be understood in terms of historical perspective. I shall therefore discuss the computer's role in three time frames: the past, the present, and the future. My discussion will be limited primarily to the ESSA Weather Bureau in the United States; military and foreign weather services will not be considered, except indirectly. Of course, the opinions to be expressed here are strictly my own and not the official viewpoint of the Weather Bureau.

### II. Past

a. Numerical Methods. The first electronic digital computers were developed at the end of World War II, and their great potential for numerical (dynamical) weather prediction was soon recognized. In 1946 a now-famous research group was established to study computer applications at the Institute for Advanced Study in Princeton, New Jersey. Numerical calculations from real initial conditions were successfully produced by the group for the first time in 1950 [Charney et al., 1950]. The results were so promising that the Joint Numerical Weather Prediction Unit (JNWP) was established by the Air Force, Navy, and Weather Bureau in Washington, D. C., in 1954, and routine numerical forecasts were started a year later. During the next few years computer forecasts were prepared by JNWP on a daily basis, but they were not sufficiently realistic or timely to have much operational impact. All official forecasts issued by the National Weather Analysis Center (NAWAC) were still prepared subjectively by experienced forecasters, and the numerical products were used merely as aids.

In the second half of the 1950's rapid progress was made by JNWP in computer technology, automatic data processing, objective map analysis, and hemispheric barotropic forecasting. By 1959 automated predictions of the 500-mb circulation were, for the first time, timely enough to meet forecast deadlines and accurate enough to be transmitted directly to the field,

untouched by human hands. The computer was now in the business of real-time forecasting, although to a limited extent, at the National Meteorological Center (NMC) in Suitland, Maryland.\*

The next major advance in operational numerical weather prediction was implementation of the three-level filtered baroclinic model at NMC in June of 1962 [Cressman, 1963]. Not only did this model improve forecasts of geopotential height at 500 mb, but also it produced acceptable height forecasts at other levels; i.e., 850 and 200mb, directly, and 700 and 300 mb, indirectly. Furthermore, it provided forecasts of additional elements, such as temperature and vertical velocity. By 1964 the computer was making official forecasts for the free atmosphere and guidance forecasts for both 1000-mb height [Reed, 1963] and quantitative precipitation [Younkin et al., 1965].

The three-level model remained operational at NMC for four years until it was replaced by the six-layer primitive equation baroclinic model in June 1966 [Shuman and Hovermale, 1968]. This PE model was a significant step forward because it produced prognostic maps of sea level pressure and boundary-layer conditions, in addition to improving the forecasts of wind and temperature at constant-pressure levels (made by the three-level model). Subsequent refinement of the model through incorporation of additional physical effects has resulted in better forecasts of precipitation, humidity, stability, and cloudiness by NMC. In addition, the PE forecast period has been extended from 36 to 48 hours on a routine basis.

b. Statistical Methods. While rapid progress was thus being made in numerical weather prediction, important advances were also taking place in the field of statistical weather forecasting. In fact, the computer proved to be almost as great a boon to statistical weather forecasting as it had been to numerical weather prediction. Its potential was first exploited by Malone and Miller at MIT during the middle 1950's [Sellers, 1956] and shortly thereafter by others in the Air Force, the Travelers Corp., and the Weather Bureau. Numerous sophisticated techniques, not previously feasible, were adapted or developed for computer application including orthogonal polynomials, screening regression, multiple discriminant analysis, and regression estimation of event probabilities (REEP). However, despite early enthusiasm, the impact of purely (classical) statistical methods upon weather forecasting has been slight. In fact, to the best of my knowledge the only computer technique of this type which is still operational is the NHC-67 method for forecasting hurricane motion by screening regression [Miller et al., 1968].

A more promising avenue has been the combination of statistical and numerical prediction. About ten years ago I used the screening program to derive multiple regression equations for 5-day mean temperature as a function of the 700-mb circulation, and these equations have been applied operationally to numerical prognostic heights continuously since that time. Similar objective methods for sea-level pressure, 5-day precipitation, and daily maximum and minimum temperatures have been used as guidance by forecasters at NMC for the past five years [Klein, 1965].

### III. Present

a. Numerical. At the present time NMC is dominated by the philosophy of the "man-machine mix." This means that certain computer forecasts, such as those for wind and temperature in the free atmosphere, are transmitted directly over facsimile and teletype; while others; e.g., quantitative precipitation and 5-day forecasts, are first modified or massaged by experienced forecasters at NMC before being issued to the field. Still other forecast products, such as sea-level pressure and maximum-minimum temperatures, are sent out in both modified and unmodified form. The consideration used to determine how a new product will be transmitted is whether the amount of improvement obtained manually warrants the extra time required to modify the machine product. The criterion is primarily one of accuracy versus time; the important factor of relative cost has thus far been largely neglected.

The increasing accuracy of numerical weather prediction and the cost-conscious climate in which we now live are combining to increase the number of purely automated forecasts and to decrease the number of manual products. For example, steps are being taken to eliminate NMC's manual modification of computer forecasts of maximum and minimum surface temperatures.

\*A good description of the first ten years of operational numerical weather prediction was published by Cressman [1965].

Also, an experiment in teletype transmission of 6-hourly FE forecasts in digital form is being expanded from eight to about fifty cities. Finally, a plan to run the FE model out to about 120 hours on a daily basis should make possible preparation of largely automated 5-day forecasts each day.

NMC is taking several steps to improve its numerical product. The single layer of moisture from about 1000 to 450 mb now carried in the FE model is slated to be replaced by three separate moisture layers in the immediate future. Increasing utilization of indirect soundings from satellite infra-red spectrometers (SIRS) should improve the initial analysis, especially in data-sparse areas. Finally, NMC plans to extend the grid of the FE model to the equator and decrease the mesh length (by about 60 percent) to two degrees of latitude during the coming year. If these changes result in further improvement, perhaps it will no longer be advantageous for experienced forecasters to modify the FE predictions of sea-level pressure and precipitation before transmittal to the field.

b. Statistical Methods. Despite the great advances in computer prediction achieved by numerical methods during the past decade, certain weather forecasts, such as visibility or probability of precipitation, still require application of statistics. As I see it, there are three basic methods of statistical forecasting by means of computers:

(1) Classical - The first or classical method is self-contained since it merely requires initial conditions, based on observation or analysis, to give a forecast for some later time. It has been used for many years to produce numerous scatter diagrams and local objective aids [e.g., George et al., 1960]. A more recent and sophisticated example is shown in figure 1, an equation derived by the REEP technique [Enger et al., 1964] for forecasting the visibility at Baltimore three hours in advance, based on ten years of hourly airways observations at a network of surrounding cities including Martinsburg, Washington, and Philadelphia. The predictors are specified in binary (yes-no) form for certain classes of visibility, relative humidity, and other surface weather elements, and the answer here is given in terms of the probability of the visibility being in the first of five categories; i.e., less than or equal to 3/8th of a mile. The reduction of variance for this category is only 32 percent and no term contributes as much as 10 percent to the forecast probability, except local persistence ( $X_2$ ) which contributes 41 percent.

Although useful for short-period forecasting, the classical method is purely statistical since it takes no account of prognostic maps. For this reason it is declining in popularity and is of only limited potential.

(2) Perfect Prog - The second computerized statistical technique has been called the "perfect prog" method. Like the first method, it utilizes a long period of observed historical data to develop the desired forecasting relationships, but these relations are derived on a concurrent, rather than a lag, basis. For example, figure 2 shows a multiple regression equation derived by screening ten winters of data for an index of present weather (clear, cloudy, or precipitation) in northern California as a function of the departure from normal of several simultaneous 700-mb heights, whose locations are plotted as squares [Klein, et al., 1965]. The equation explains 51 percent of the variance and illustrates the well-known fact that wet weather in California in winter is associated with southwesterly flow from a deep trough just offshore; conversely, fair weather is accompanied by north-easterly flow around a strong ridge.

To use such an equation for making a forecast, one must apply it to a prognostic 700-mb chart, usually produced numerically. Errors in the numerical prog will inevitably produce corresponding errors in the statistical forecast, which depends on an equation derived from observed maps; i.e., perfect progs. However, the statistical prediction will improve each time the numerical model improves, and this has actually happened to 5-day mean temperature forecasts at NMC during the past decade. The main advantage of this method is that it is based on a long period of record, so that stable forecasting relations can be derived for individual locations and seasons once and for all. For this reason it is probably the most commonly used statistical forecasting scheme at the present time.

(3) Imperfect Prog - For lack of a better name, I shall call the third computerized statistical technique the "imperfect prog" method. Like the second method, it derives its forecasting relations on a concurrent or simultaneous basis. However, instead of a long period of observed data, the developmental sample now comprises a short period of prognostic data produced directly by numerical predictions. A good example is illustrated

in figure 3 [U. S. Dept. of Commerce, 1969], which gives the frequency of precipitation in ten cities of the Weather Bureau's Southern Region as a function of the 700-mb relative humidity (on the left) and the 12-hour net vertical displacement of air parcels (on the right), both forecast 24 hours in advance by a three-dimensional trajectory technique

**REEP TECHNIQUE**  
(Regression Estimation of Event Probabilities)

Sample Prediction Equation for Baltimore 3-Hour Visibility

Category	Ceiling		Visibility	
	Limits (Feet)	RV (%)	Limits (Miles)	RV (%)
1	≤ 100	28	≤ 3/8	32
2	200 - 400	25	1/2 - 1-3/8	18
3	500 - 900	26	1-1/2 - 2-1/2	17
4	1000 - 2900	30	3 - 4	21
5	≥ 3000	58	≥ 5	48

$$P_1 = .02 - .01X_1 + .41 X_2 + .01X_3 - .03X_4 + .01X_5 + .01X_6 - .00X_7 + .07X_8 + .09X_9 \dots - .01X_{36}$$

$P_1$  = Conditional Probability of Category 1 VIS

$X_1$  = BAL VIS ≥ 5 miles

$X_2$  = BAL VIS ≤ 3/8 mile

$X_3$  = MRB VIS ≥ 5 miles

$X_4$  = BAL VIS 1/2 - 1-3/8 mile

$X_5$  = BAL VIS 5 miles

$X_6$  = BAL VIS 1-1/2 - 2-1/2 miles

$X_7$  = DCA RLH ≤ 80%

$X_8$  = DCA RLH ≥ 98%

$X_9$  = MRB VIS ≤ 3/8 mile

.

.

.

$X_{36}$  = PHL RLH 81-90%

Figure 1. Portion of multiple regression equation for forecasting the probability ( $P_1$ ) that Baltimore's visibility 3 hours in advance will be less than or equal to 3/8ths of a mile (Category 1). The box gives the class limits for five categories of ceiling and five categories of visibility, and a separate regression equation is derived for each category. The reduction of variance (RV) for each equation is given following the predictand class limit.

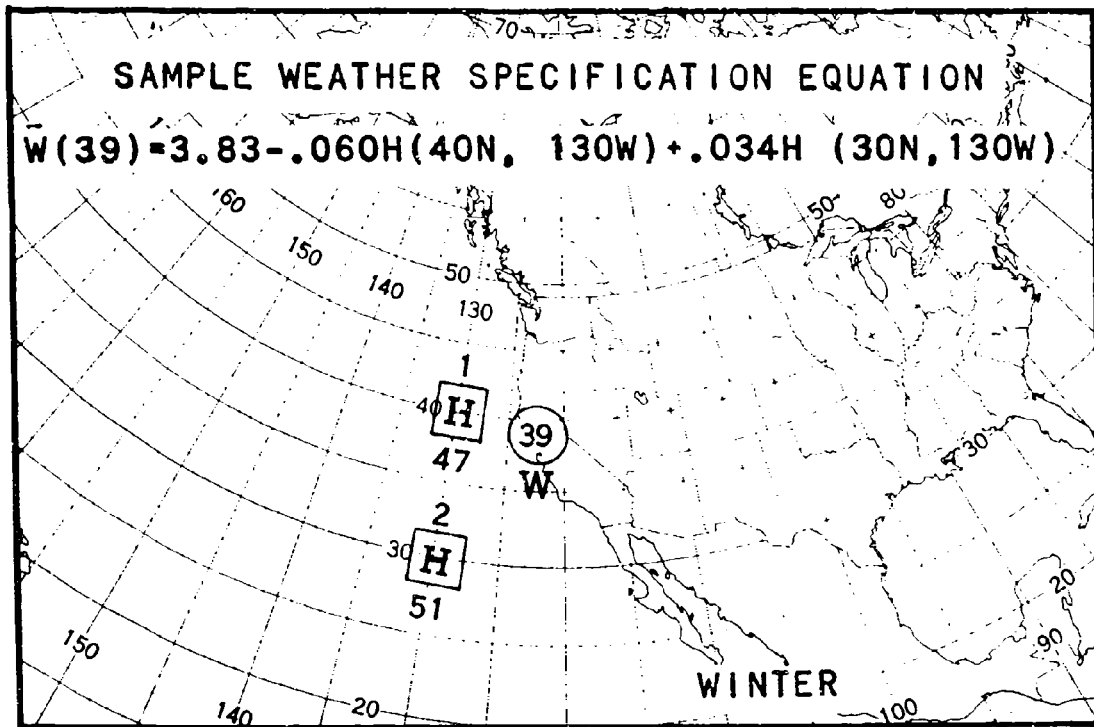

Figure 2. Multiple regression equation for specifying the weather index (W) in circle number 39 (located by circle) during the winter as a function of the concurrent 700-mb height anomaly (H in tens of feet) at indicated points.

**700 MB. TRAJECTORY FORECASTS  
DECEMBER 18 - JANUARY 9, 1969**

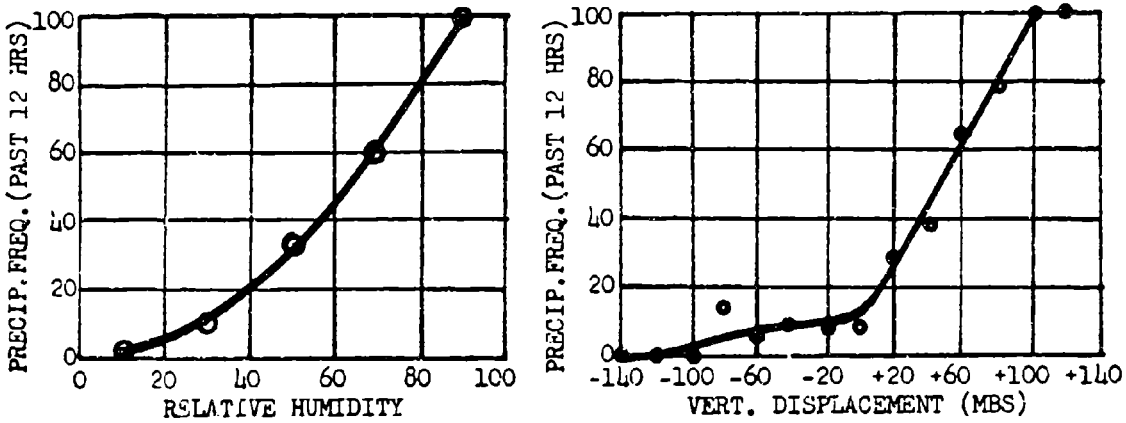

Figure 3. Graphical relationship between probability of precipitation at 10 cities in the WB Southern Region and two 700-mb parameters predicted 24 hours in advance by the TDL 3-dimensional trajectory technique.



developed in the Techniques Development Laboratory [Reap, 1968] and now operational at RMC. Although based on only a short period of record, from December 18, 1968 to January 9, 1969, the graphs can be useful in helping field forecasters translate computer predictions into surface weather. Especially noteworthy is the sharp increase in precipitation probability as the vertical displacement changes from downward to upward motion.

A computerized application of the imperfect prog concept is illustrated in figure 4, which gives the probability of precipitation (PoP) during a twelve-hour period "today" in winter as a function of saturation deficits ( $S_d$ ) and sea-level pressure (SLP) predicted by the Sub-Synoptic Advection Model (SAM) [Glahn et al., 1969], as well as precipitation amounts and mean relative humidities predicted by the PE model. The forecast equation contains twelve terms in binary form and explains about half the variance [Lovry, 1969]. Since it was derived directly from the output of numerical models which have been operational for only a short time, it was generalized by combining data from 79 cities in the eastern half of the United States. Not only does this procedure neglect local effects, but also it requires the equations to be rederived or updated every time the numerical model changes.

On the other hand, this method automatically takes account of model bias and can include predictors not available to the perfect prog method such as vertical velocity and boundary layer temperature. Despite its drawbacks, forecasts of probability of precipitation produced operationally by equations like that illustrated in figure 4 have been competitive with the

#### PROBABILITY OF PRECIPITATION

12-hr PoP 1200-0000Z:

Predictor	Contribution to PoP (%)	Cumulative Reduction of Variance
1) Constant	42.67	
2) SAM $S_d \leq 0$ at 18Z	10.73	.3606
3) PE 12 hr. precipitation $\leq .05$ at 00Z	-7.675	.4334
4) SAM $S_d \leq 75$ at 21Z	10.19	.4529
5) SAM $S_d \leq -5$ at 15Z	12.68	.4669
6) PE mean relative humidity $\leq 70\%$ at 18Z	-6.329	.4761
7) PE 12 hr. precipitation $\leq .20$ at 00Z	-12.97	.4817
8) SAM SLP $\leq 1015$ at 18Z	6.439	.4863
9) SAM $S_d \leq 45$ at 15Z	8.633	.4889
10) PE mean relative humidity $\leq 90\%$ at 00Z	-7.364	.4912
11) SAM $S_d \leq -15$ at 15Z	8.616	.4925
12) PE 12 hr precipitation = 0 at 00Z	-6.422	.4937

Figure 4. Components of multiple regression equation used to predict the probability of precipitation (PoP) between 1200Z and 0000Z in the eastern half of the United States in winter from SAM and PE predictors.

best subjective forecasts. This is illustrated by figure 5 which compares SAM (solid) and local forecast (dashed) scores at eleven cities during the past ten months (3022 cases). The two sets of scores show similar seasonal trend, with only minor monthly differences. Since low scores are desirable, the overall averages in the lower right indicate that the computer PoP forecasts have been equal or slightly superior to the official forecasts issued to the public by Weather Bureau local offices. In view of this result, the Techniques Development Laboratory has recently embarked upon an ambitious new project to expand this approach to 254 cities in all 50 States for periods from 12 to 60 hours in advance, utilizing numerical input from both the FE model and the TDL three-dimensional trajectory model.

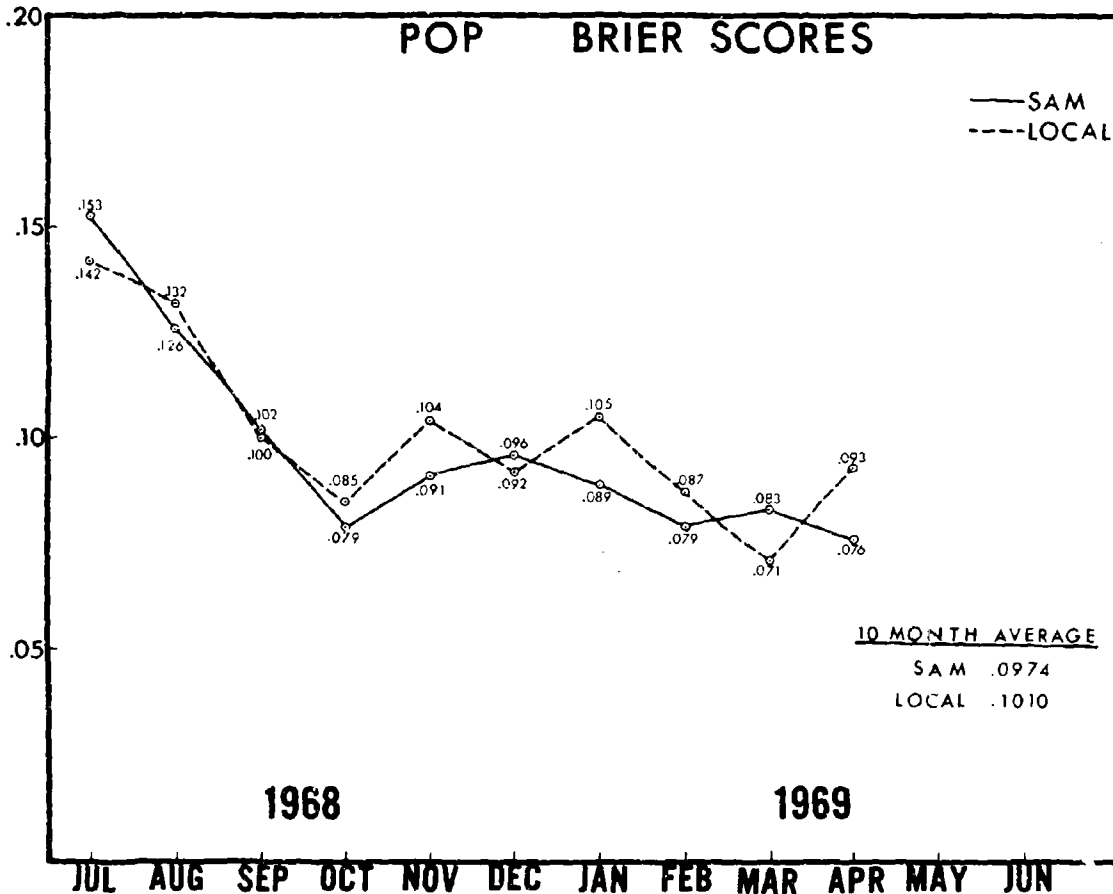

Figure 5. Comparative verification for forecasts of probability of precipitation (PoP) prepared by the SAM method and issued by local Weather Bureau offices at 11 cities in the eastern United States each month from July 1968 through April 1969.

The difference between the three statistical methods is illustrated in schematic form in figure 6. The classical method simply flows directly from the data observed today to forecasts of the weather for tomorrow. The perfect prog method is more complicated since it derives the weather tomorrow as a function of tomorrow's circulation, as shown by the solid arrow, but applies its forecast relations to numerical prognostic charts which simulate the observed circulation, as shown by the dashed arrow. The imperfect prog method is relatively simple since it goes directly from the numerical forecast to the predicted weather.

## THREE METHODS OF STATISTICAL WEATHER FORECASTING:

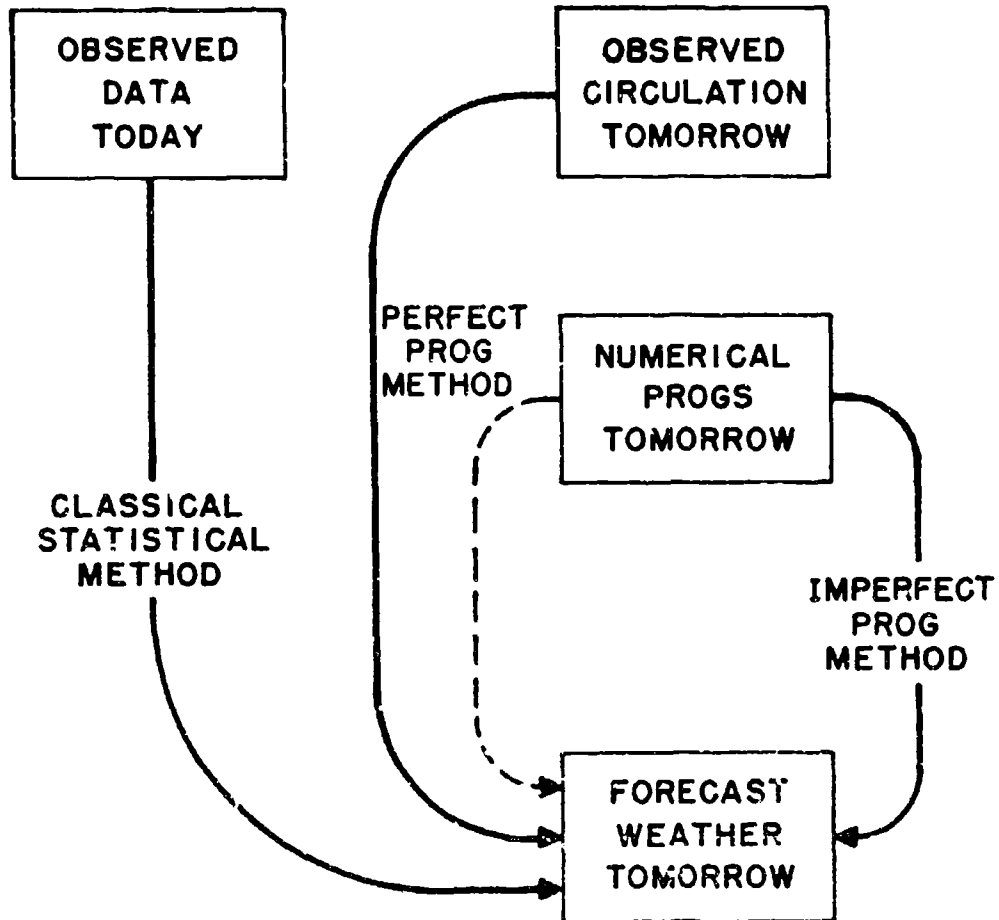

Figure 6. Schematic diagram illustrating three basic methods of statistical weather prediction.

Of course the three statistical methods described above are not mutually exclusive. The first two can be combined by utilizing as predictors of tomorrow's weather both surface weather elements observed today and upper air features for tomorrow which are observed in the derivation but predicted numerically in the application. This is essentially what is done today in preparing the NMC automated forecasts of maximum and minimum temperature, which are localized on the basis of 18 years of record at 131 different cities [Klein et al., 1967]. It should be possible to improve these forecasts by using them as predictors in the third method, along with such numerical products as boundary-layer temperature and wind, mean relative humidity, surface temperature and dew point, stability, etc. Even though the resulting equation would have to be generalized because of small sample size, the forecasts

may well prove more accurate than those obtained from either the perfect or imperfect prog methods taken alone.

#### IV. Future

a. Weather Central. Now for a brief look into the future. On the basis of personal experience in the Extended Forecast Division, I am reluctant to make a long-range forecast about the computer's role in forecasting in the 1970's. Nevertheless, in view of the promising results obtained thus far and the strong endorsements given by the field, it would appear that some form of the imperfect prog method (perhaps in conjunction with the classical and perfect prog methods) will be the most popular statistical technique run on computers in the future. It will probably be extended to many additional weather elements including ceiling, visibility, sky cover, temperature, wind, humidity, and severe local storms. After a few years of data have been accumulated, it should be possible to derive reliable equations for individual stations, as well as large regions. The method can be applied most efficiently on large computers at a central location as an adjunct to the numerical prediction itself. Thus I foresee the day in the not too distant future when this type of combined statistical-numerical output will provide accurate guidance to the field for nearly all surface weather elements.

What then will happen to the man-machine mix at NMC? I believe it will prove to be too expensive, too slow, and too subjective for the requirements of the 1970's. I think it will gradually wither away and be replaced by a completely automated system, producing improved numerical as well as statistical forecasts. These forecasts will probably be based on fine-scale, boundary-layer numerical models, as well as large-scale, hemispheric and global ones.

b. Field Offices. Although I visualize no room for the human forecaster in the weather central of the 1970's, I believe he will still play an important role at regional weather centers and state forecast offices. Here he may tailor some of the centralized computer forecasts to local conditions or update them on the basis of data not available to the computer because of their late receipt or localized nature. For the most part, however, he will accept the computer forecasts without change and will devote his attention to elements, areas, and time periods not included in the guidance he receives from the central office. For example, the field forecaster may be asked to supply detailed information about a meso-scale sea breeze or mountain wind a few hours before onset, or he may be called upon to predict snow accumulation in different portions of a large metropolitan area when a storm appears imminent. Much of his time will be spent on weather watch and warnings, and his main responsibility will be to keep the short period forecast in line with the latest observation.

To help with these tasks, the field forecaster will probably have some computer capability available in his local office. This statement does not necessarily mean a field computer, but rather implies some form of remote terminal linked to a large central computer by telephone or facsimile lines. Another likely possibility is extensive use of commercial time-sharing, such as now being tested by the Weather Bureau for automatic computation of rawinsonde observations.

Local computer capability will assist the field forecaster in many ways. Its functions may include calculation of local objective forecast aids, monitoring of forecasts for consistency and accuracy, plotting and analysis of hourly observations for limited areas, verification of subjective and objective forecasts, composition of forecasts and warnings, plotting of radiosonde ascents, and dissemination of forecasts and briefings.

In all these activities the computer will prove to be invaluable to the field forecaster, but it will still be mostly an aid. In other words, the concept of the "man-machine mix" will probably predominate at local forecast offices throughout the 1970's. Complete automation of weather forecasting, even on the local level, will be a later step, and I do not look for its attainment until the decade of the 1980's at the earliest. By the turn of the century, however, all aspects of weather forecasting should be automated, and the long evolution from subjective to objective forecasting will be completed.

\*Glahn et al. [1969] have recently suggested the acronym MOS or Model Output Statistics for the imperfect prog method since it matches the output of numerical models with observations and then computes regression equations.

#### REFERENCES

- Charney, J., R. Fjortoft, and J. von Neumann, "Numerical Integration of the Barotropic Vorticity Equation," Tellus, Vol. 2, No. 4, Nov., 1950, pp. 237-254.
- Cressman, G. P., "A Three-Level Model Suitable for Daily Numerical Forecasting," WMC Technical Memorandum No. 22, U. S. Weather Bureau, Washington, D.C., 1963, 27 pp.
- Cressman, G. P., "Numerical Weather Prediction in Daily Use," Science, Vol. 148, No. 3668, April 16, 1965, pp. 319-327.
- Enger, I., J. A. Russo, Jr., and E. L. Sorenson, "A Statistical Approach to 2-7-hr Prediction of Ceiling and Visibility. Volume I, "Technical Report No. 2 on Contract Cwb-10704, 7411-118, The Travelers Research Center, Inc., Hartford, Conn., Sept. 1964, 48 pp.
- George, J. J., "Weather Forecasting for Aeronautics" (with contributions from R. J. Shafer, P. W. Funke, W. R. Biggers, E. B. Visscher, R. M. Whiting, R. E. Bailey, and A. E. Stakely), Academic Press, New York, N. Y., 1960, 673 pp.
- Glahn, H. R., D. A. Lowry, and G. W. Hollenbaugh, "An Operational Subsynoptic Advection Model," ESSA Technical Memorandum WBTM TDL-23, Techniques Development Laboratory, Silver Spring, Md., July 1969.
- Klein, W. H., "Application of Synoptic Climatology and Short-Range Numerical Prediction to Five-Day Forecasting," Research Paper No. 46, U. S. Weather Bureau, Washington, D. C., June 1965, 109 pp.
- Klein, W. H., C. W. Crockett, and J. F. Andrews, "Objective Prediction of Precipitation and Cloudiness," Journal of Geophysical Research, Vol. 70, No. 4, Feb. 15, 1965, pp. 801-813.
- Klein, W. H., F. Lewis, and G. P. Casely, "Automated Nationwide Forecasts of Maximum and Minimum Temperature," Journal of Applied Meteorology, Vol. 6, No. 2, April 1967, pp. 216-228.
- [Lowry, D. A.], "Operational Forecasts with the Sub-Synoptic Advection Model (SAM) - No. 3," Technical Procedures Bulletin No. 21, ESSA, Weather Bureau, Weather Analysis and Prediction Division, Silver Spring, Md., Feb. 3, 1969, 11 pp.
- Miller, B. I., E. C. Hill, and P. P. Chase, "A Revised Technique for Forecasting Hurricane Movement by Statistical Methods," Monthly Weather Review, Vol. 96, No. 8, Aug. 1968, pp. 540-548.
- Reap, R. M., "Prediction of Temperature and Dew Point by Three-Dimensional Trajectories," ESSA Technical Memorandum WBTM TDL-15, Techniques Development Laboratory, Silver Spring, Md., Oct. 1968, 20 pp.
- Reed, R. J., "Experiments in 1000-Mb Prognosis," National Meteorological Center Technical Memorandum No. 26, U. S. Weather Bureau, Washington, D. C., 1963, 31 pp.
- [Sellers, W. D.], "Studies in Synoptic Climatology," Final Report of Synoptic Climatology Project No. N5ori-07883, Department of Meteorology, Massachusetts Institute of Technology, Cambridge, Mass., March 15, 1956, 215 pp.
- Shuman, F. G. and J. B. Hovermale, "An Operational Six-Layer Primitive Equation Model," Journal of Applied Meteorology, Vol. 7, No. 4, Aug. 1968, pp. 525-547.
- U. S. Dept. of Commerce, ESSA, Weather Bureau, Southern Region, "Southern Topics and Personnel," Fort Worth, Texas, March 1969, pp. 6-7.
- Younkin, R. J., J. A. LaRue, and F. Sanders, "The Objective Prediction of Clouds and Precipitation Using Vertically Integrated Moisture and Adiabatic Vertical Motions," Journal of Applied Meteorology, Vol. 4, No. 1, Feb. 1965, pp. 3-17.

## THE ROLE OF THE MAN IN WEATHER FORECASTING

J. J. George  
Eastern Air Lines, Inc.

For much of last winter, we had in our company a high level staff meeting about once a month which I was required to attend.

All of us in this business of weather forecasting are accustomed to being on the receiving end of good natured comments, sometimes ranging into rather vicious barbs. Prior to the start of one of these meetings one of our senior vice presidents in a rather public manner said something to me like the following: "You have got the biggest racket I know of -- when you miss a forecast, you simply say, 'I missed it' and that is all there is to it. I don't know anyone else who has a racket that good."

Like many people, I am one of those types who think of the proper answer in situations of this kind on the way home, rather than when I need it. On that particular day, the best I could do was just answer that everybody had to have a racket of some kind and let it go at that.

At the next staff meeting, however, I brought the matter up again by asking my friend, the V. P. in making decisions was not one of his major duties. He being a very cagey fellow said: "Well, it was involved all right," and after some pressing he agreed that decision making was of some importance; however, he went on to say that when he made a decision, he waited until all of the obtainable facts bearing on the matter were laid out so that he had the best possible basis upon which to make the decision. I then asked what percentage of time he felt that the decisions he made were accurate and the best one that could be made. Again he refused to make an estimate so I asked him if he felt that he made better than 50 per cent of his decisions accurately and he agreed that he felt he did. I said, how about 100 per cent? Well, no -- so he finally settled for somewhere above 50 but less than 100 per cent.

From this point, I went on to draw the similarity between the proper use of a weather forecast and the ordinary role of making decisions in a business venture. In reality they are one and the same thing. A weather forecast, if it is not to be used to help in making a more accurate decision is only a scrap of paper or a few words that are meaningless. Furthermore, in making a weather forecast, it is often necessary to delay its final issuance until certain supporting materials and facts are available. Just as in any business decision one must wait until the facts are in.

Some of the decisions that are made in aeronautics are made almost wholly upon the product of computers, but these are, I am sure greatly in the minority. The point I want to make is that the man in the equation -- in this case the Meteorologist -- can, and should aid and share in the making of the operating decision even if the forecast is entirely the product of a machine and is couched perhaps in terms of mathematical probability.

I think that the main danger that we are encountering in Meteorology Computer use is that we tend to become oversold on what computers are able to do. Off hand, I can think of no facet of human experience that has come along quite so explosively as this one has. When this happens, the people who are engaged in this area, in this case computers, generate so much enthusiasm and momentum that they tend to carry along the rest of us further and faster than we should really go.

In Barron's Weekly recently, Charles P. Lecht, President of Advanced Computer Techniques Corporation, was quoted as follows: "Whenever I am told today about what's been or being done with computer systems, great waves of skepticism well up in me." I think this statement is extremely important for two reasons: (1) is that the man is in a position peculiarly well suited to make the judgment properly and (2) is that is something that is seldom questioned by the non-computer types. I believe what he is saying is that many times we tend to program and use a computer when we really would find that using the man was more efficient and cheaper.

In Meteorology, we have made some remarkable strides in the use of equations for solving numerically the basic behavior and pattern development of global weather. Without the computer it seems unlikely that man could ever have attained this advanced use of data.

Once the Meteorologist is given the numerical patterns in the future, however, he then must at least for now, assume the responsibilities for the development of the actual pattern of weather that will be associated with the numerical distribution involved. It does not seem to me now that this process can effectively be assumed by machines in the near future, but on the other hand it would be folly not to recognize that some day it can and will be done. I think someone should be planning for this day so that we do not too abruptly terminate or greatly distort the careers and training of an appreciable number of highly educated people. For after all let us not forget that in the final analysis it is human beings who are of paramount importance not mere machines.

We have been seeing this process work in airline meteorology; so I feel somewhat qualified to speak to the question. A few years ago the five largest United States Flag Carriers employed some 235 Meteorologists. Today, that figure is about 172, a 27 per cent decrease. This has been brought about by better and more extensive communications, making it possible for one Meteorologist to take care of a much wider area than before; centralization has been the rule and this promotes more efficient use of manpower, but neither can we neglect the role that the computer plays in this retrenchment. For example it is possible and is now being done for airlines to obtain computer to computer hookups with the central United States product of wind and temperature throughout the northern hemisphere and so prepare detailed flight plans for wherever they are needed. Tomorrow, this information will be world wide. Obviously the role of man has become that of monitor rather than creator and this takes a fewer number of people by a considerable amount.

I suppose I should mention, but there is no need to dwell on, the role of computers in the actual drawing of weather maps and prognostic charts. You are all aware of these developments and many are much more familiar than I with this field. Nevertheless, it goes into the whole consideration of the shrinking world of the Meteorologist, for not only can the machine do this job better in many cases than can man, it can do it from one central facility and by modern communications issue the product wherever it may be needed. Obviously a large number of Meteorologists who formerly had to do this work in the field, need no longer to do so. I suppose the polite phrase is that they are "freed for more important efforts" and in lots of cases this must be true. But there is also a proportion of Meteorologists who are not needed for "more important jobs".

As time moves on, we will certainly refine computer techniques and pour more and more data into the greedy maws of machines. We will find then that we must interrelate various programs to produce an integrated world product. It is in this field in the next two decades that I believe the Meteorologist will make his greatest contributions.

Consider the impact of the new observational programs for a moment, such as constant level balloons reporting through satellite communications and the actual gathering of data from satellites themselves, the use of automatic marine weather reporting stations and the expansion of upper air sounding stations particularly in the southern hemisphere where they are most needed and the advent of rocket sondes. We have not even begun to utilize properly pilot weather reports, and I am certain that there will be other developments producing this type of information which we do not even dream of at present.

It is completely unthinkable that this mass of information could ever be utilized on a global basis or even a national basis without the most sophisticated machine methods. I think you will agree, however, that the task of integrating and utilizing these vast new sources of data is a formidable one and will require large numbers of highly specialized Meteorologists which may, and probably will, more than compensate for the shrinkage of some of our present tasks. This simply means that we must plan for the transition so that our Meteorologists can be cross-trained for these new jobs as well as making room for the indoctrination of many new people.

To get back to the more mundane side of present day Meteorology, I can think of three areas where man will be necessary for a long time to come.

1. Weather Forecasting Itself. Even though we may have a computer-produced probability forecast, the interpretation of a human forecaster and his aid in using this tool to make proper decisions will long be necessary. Furthermore, there are many areas in weather forecasting that are not amenable to computer programming as we know it today. Some examples might be in the forecasting of local weather and the evaluation of the effect of air trajectories and the weather along them upon these forecasts. I am sure that such examples will come to mind for all of us in almost every phase of weather forecasting.

2. I think there will be unexpected fall outs requiring the attention of human forecasters. As an example, we are headed in the airline industry toward what we call Category III landings and take off which involves visibilities approaching zero. To attain the operations at this level is an extremely expensive procedure requiring very sophisticated and expensive hardware and extremely costly training of air crews. In my opinion, a better way would be to develop means of dissipating low visibility due to fog by artificial means. Presently this appears to be possible but the means are crude and restrictive; however, this will inevitably be improved and refined and when it is, I believe that a Meteorologist will be required to determine when and where preparations for use of this tool should be made and guide its application.

3. Forecast Research. Although computers may be used as a potent tool in this field, the basic job has got to be and will continue to belong to man. Let me show you some slides of practical forecast development techniques that will illustrate my point. I think it is quite possible that such forecasting techniques may be more and more slanted for use in computers and I will point out how this might be done at least partially in these two specific examples I will show. Although these examples happen to be produced by my organization, all of you can produce your own.

I can summarize what I have said about like this:

The basic role of the Meteorologist must always be to aid in the making of operational decisions of some kind. This will be true until 100 per cent perfect forecasts are possible, and I do not expect that any of us here will live to see that day.

I think that the utilization of Meteorologists is changing rapidly in this period and that the traditional and current jobs that Meteorologists perform are being shrunken by machine and communication techniques; but on the brighter side, I believe that these very same techniques generate such a plethora of new data and methods that the new generation of Meteorologists will be relatively more numerous than those in the past. As a corollary, I think that all large Meteorology organizations should make careful and thorough plans to utilize and to cross-train present Meteorologists for this new age and not wait until we have to make a crash program utilizing people who are not specialists in this field for jobs in which a Meteorologist would be most needed.



# THE MAN-MACHINE MIX IN APPLIED WEATHER FORECASTING IN THE 1970S

By

L. W. Snellman  
U. S. Weather Bureau

## ABSTRACT

Significant improvement in some phases of operational forecasting over the past several years is demonstrated and is attributed to the transition from a totally manual to a "man-machine mix" operation. This is used as the departure point in discussing expected changes in current forecasting practice over the next several years. The "man-machine mix" has been replaced by a machine product only if the quality of this end product is comparable or better than the "man-machine mix" product. The number of machine-produced products which are directly suitable for users is rather limited, and it is difficult to see how this number will increase significantly in the next several years. Therefore, the conclusion is reached that while most centrally prepared forecast guidance for field forecasters may soon be a purely machine product, man will provide an important input into improved weather services in the preparation of short-period general public forecasts, specialized user forecasts, and warnings. This conclusion is discussed in light of recent atmospheric predictability studies and the lack of success to date of machine aviation terminal forecasting.

## I. INTRODUCTION

It is a privilege and a pleasure to be present at this distinguished AWS Conference. I spent many wonderful years with AWS, and it is good to renew acquaintances and friendships here.

In approaching this very challenging topic of man-machine mix, I decided to touch base with my counterparts in other regions of the Weather Bureau\* as well as with Mr. Charles Roberts at Weather Bureau Headquarters and Mr. Beckwith of United Airlines. I was pleasantly surprised to see the more or less unanimity of opinion of their ideas of the role of man and machine in applied weather forecasting in the 1970s. The surprise was pleasant because their ideas were in close consonance with mine. However, the views expressed in this paper are mine and should not be considered as representing Weather Bureau policy.

To explore these ideas, I shall take a somewhat similar approach to Dr. Klein in looking back briefly into history to show the effects of machines (computers) on applied weather forecasting. From this history we can glean some ideas on which to base a projection of operations in the 1970s.

## II. PREPARATION OF A FORECAST

Preparation of applied weather forecasts went through a large change during the 1960s. At the beginning of this decade, forecast preparation was mainly a one-man effort, with most forecasters using the analytic rather than prognostic NMC facsimile output. As prognostic charts from the computer improved, forecasters gradually shifted their attention to prognostic charts. Today the final forecast is the result of a team effort of the National Meteorological Center and field forecaster. Since a large percentage of present prognostic guidance from NMC is a man-machine mix product, we can represent today's applied forecast procedure as:

$$(\text{Man})^2 + \text{Machine} = \text{Final Forecast.}$$

---

\*Responses from the regions came from Mr. Carlstead in Hawaii, Dr. Diemer in Alaska, and Mr. Dunn in New York.

# FORECAST FUNNEL

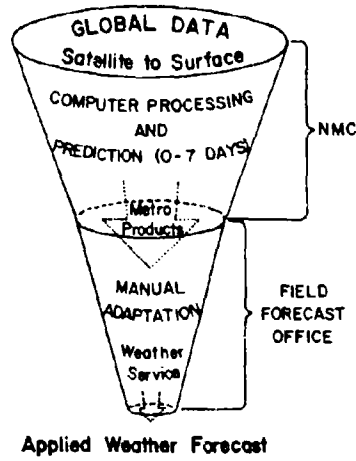

Figure 1.

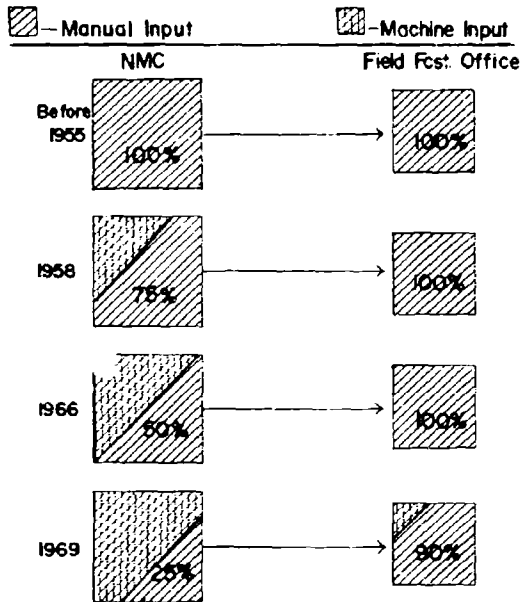

Figure 2. The Man-machine mix in operational weather forecasting 1950 - 1969.

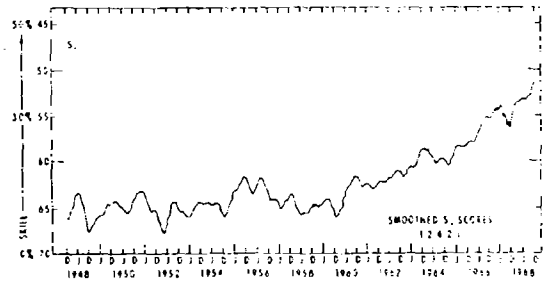

Figure 3. NMC 30-Hour surface prognostic charts 1947-1968.

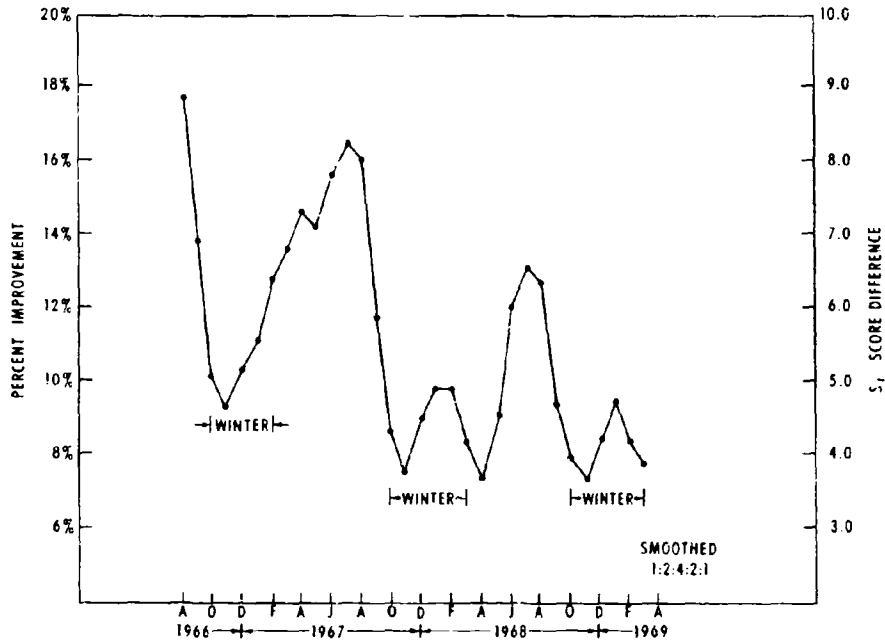

Figure 4. Man-machine mix: - 30-hr surface prog improvement over 36-hr P. E. prog, June 1966 to May 1969.

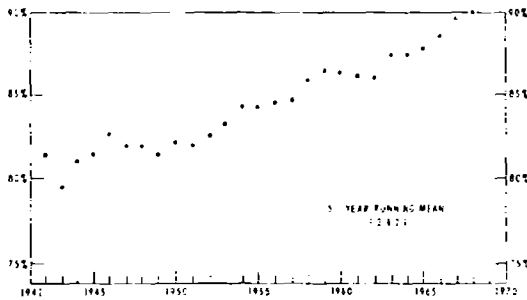

Figure 5. Percentage of correct weather and temperature forecasts by U. S. Weather Bureau, 1940-1968.

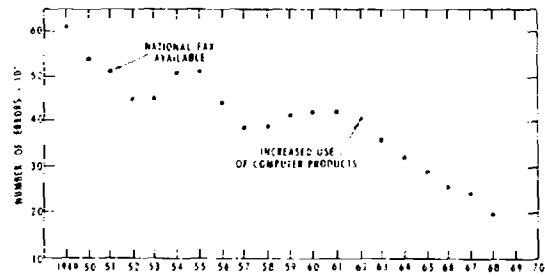

Figure 6. Gross temperature forecast errors 1948-1968, Salt Lake City, 3-yr running means (1:2:1).

### WESTERN REGION TEMPERATURE FORECASTS

April - Sept. 1967

		Number Fcsts	% Imprt. over 24-hr Change	% Mean Forecast Error by Class			
				0-5°	6-10°	11-15°	>15°
1st. Prd.	LOCAL:	7434	+32	86	11	2	0
	NMC:	8042	-7	70	21	6	3
2nd. Prd.	LOCAL:	7430	+22	81	16	3	+1
	NMC:	8040	-19	65	25	7	3
3rd. Prd.	LOCAL:	7436	+10	75	19	5	1
	NMC:	8039	-27	73	20	5	2

Figure 7a.

### WESTERN REGION TEMPERATURE FORECASTS

Oct. 1967 - March 1968

		Number Fcsts	% Imprt. over 24-hr Change	% Mean Forecast Error by Class			Class #3
				0-5°	6-10°	11-15°	
1st. Prd.	LOCAL:	8046	+37	80	16	3	0
	NMC:	8052	+8	66	24	7	3
2nd. Prd.	LOCAL:	8046	+22	73	21	5	1
	NMC:	8052	-3	60	27	10	3
3rd. Prd.	LOCAL:	8046	+10	66	24	8	2
	NMC:	8052	-11	56	28	10	6

Figure 7b.

### WESTERN REGION PRECIPITATION FORECASTS

April - Sept. 1967

		No. Fcsts	% Pcpn. Cases	% Correct	% Imprt. over Climat
1st. Prd.	LOCAL:	7427	13	90	30
	NMC:	8042	13	88	—
2nd. Prd.	LOCAL:	7430	13	88	16
	NMC:	8040	13	88	14
3rd. Prd.	LOCAL:	7427	13	87	9
	NMC:	8039	13	87	10

Figure 8a.

### WESTERN REGION PRECIPITATION FORECASTS

Oct. 1967 - March 1968

		No. Fcsts	% Pcpn. Cases	% Correct	% Imprt. over Climat
1st. Prd.	LOCAL:	8046	19	88	43
	NMC:	8052	19	85	—
2nd. Prd.	LOCAL:	8046	19	83	20
	NMC:	8052	19	82	13
3rd. Prd.	LOCAL:	8046	19	81	11
	NMC:	8052	19	82	8

Figure 8b.

It might be better to change the plus sign to a times sign to give the machine term due weight. But the important point here is that the final weather forecast of today is prepared manually, based to a large extent on man-machine-mix centralized guidance material.

Certainly this team, consisting of a major forecast center (i.e., NMC) and the local station, will continue to be the combination that produces our weather service throughout most, if not all, of the 1970s. Figure 1 attempts to give a graphic summarization of this conclusion.

### III. CONTRIBUTION OF COMPUTERS TO APPLIED WEATHER FORECASTING

The computer made strong inroads into this team operation with the establishment of JNWP in 1954. Figure 2 summarizes the change from a purely manual team operation to today's man-machine mix. It really wasn't until after automatic data processing (ADP) became operational in 1958 that the computer had an impact on the operational forecast. By the advent of 1969 both upper-air analyses and prognoses issued by NMC were largely computer-produced, with the main manual production being surface analysis and prediction and "weather" forecast guidance.

Machine techniques are not yet being used in field forecast offices to any significant extent, i.e. < 10%. Two of the major drawbacks to more automated field operations at present are economic limitations and lack of appropriate automated techniques. However, there are tests now under way and plans on the drawing board, some of which were discussed by earlier speakers, which suggest that this situation will change rather soon; and I shall speak to this point later. Nonetheless, incorporating the machine into centralized operational forecasting procedures during the 1960s significantly increased the quality of forecasts issued by local stations.

Figure 3 shows the dramatic improvement in accuracy after 1958 in NMC's man-machine mix 30-hour surface prognostic charts. Prior to 1958 this NMC product was based on subjective techniques and forecaster experience. Today it is based largely on machine prognoses.

Figure 4 shows the improvement that NMC makes on the machine-produced P.E. surface prognostic chart. The first point of interest is that greater improvements are made in summer than in winter, and second is that man's improvements are getting fewer with time (i.e., as the machine product improves).

Improvements in operational weather forecasts closely parallel improvements in NMC machine and man-machine-mix weather guidance. Figure 5 shows the verification of local weather forecasts (temperature and precipitation) prepared routinely at Chicago from 1940 through 1968. Improvement after 1958 is related to operational ADP, after 1962 to Cressman's 3-L model, and after 1966 to NMC's use of Shuman's operational P.E. model. Figure 6 shows the dramatic reduction in gross maximum-temperature errors ( $> 10^{\circ}$ ) for tomorrow (essentially a 36-hour forecast) at Salt Lake City. This reduction is attributed to use of NMC's machine and man-machine-mix improved guidance.

An important point to keep in mind, however, is that the man--especially the field forecaster--has been making a significant improvement over the temperature forecast guidance he receives. Figures 7a and 7b give the latest data available published by the Weather Bureau. Note especially the higher percentage of large errors by NMC as compared to Western Region local stations. These large forecast errors are most significant to the user. Figures 8a and 8b show precipitation verification results for the same period. Note there is only a slight improvement over NMC by local stations in the first 12-hour forecast period [8].

### IV. TWO TYPES OF MACHINE PRODUCTS

At this time we should distinguish between the two types of computer products available; namely, a final forecast ready for direct use, and a prognostic product that is used as guidance in preparing the final forecast for a user. Present machine forecasts of upper winds and temperatures are used directly by aviation users. Viewed from an aviation support point of view, the computer makes this forecast and man is eliminated. However, viewed from the public, fire weather, etc., support point of view, the computer has provided only guidance for preparation of the final forecast. Thus computers are useful as forecasters per se if, and only if, fixed programs give a forecast to the user in final form [1]. There are very few computer-produced forecasts of this type at present, and I do not expect their

# MAN-MACHINE MIX IN OPERATIONAL WEATHER FORECASTING IN 1970's

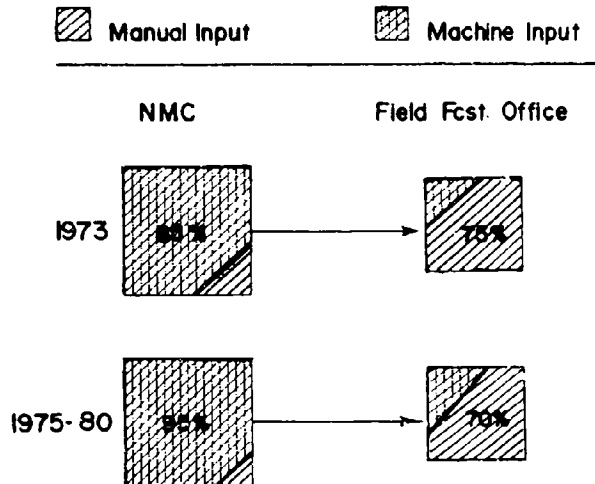

Figure 9.

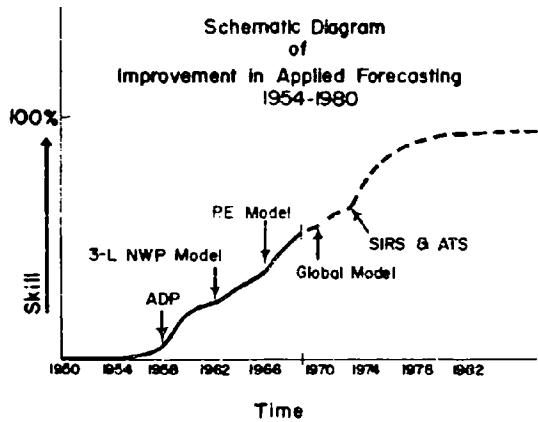

Figure 10. Schematic Trend of Improvement in Applied Forecasting, 1954-1980

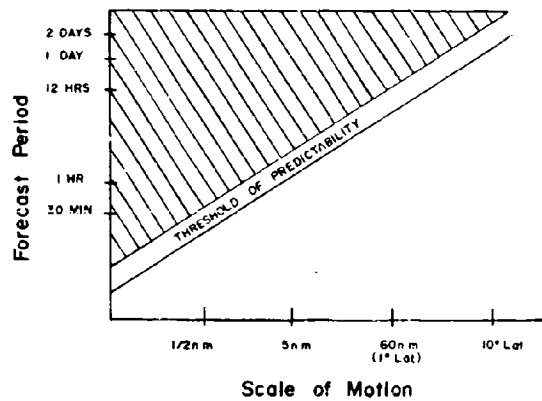

Figure 11. Predictability as a function of Scale of Motion (after Robinson and Lorenz).

number to increase significantly in the next five years.

The remaining computer output is termed guidance. To make this guidance useful involves one or more of the following manual processes: putting the forecast in user language, integrating the guidance with information not available to the computer (i.e., later data, local data, and small-scale analysis which take into account local orographic effects), updating and detailing the forecast by use of radar observations, etc. Involved then are such manual tasks as using guidance in preparing spot fire-weather forecasts, making weather forecasts for the public, detailing areas of heavy-snow accumulation, determining time of arrival of squall lines, defining local air-pollution potentials, etc. This list is long now, and it seems to me it will get longer in the 1970s as improved applied weather forecasts result in increasing application of meteorological predictions to business and other activities. Reasoning along these lines, it is then easy to expect that in the 70s all meteorological products emanating from NMC or, in the case of AWS, the Global Weather Center will gradually become purely machine products; but the final weather service will be a man-machine mix with the man predominating. This is depicted schematically in Figure 9.

#### V. MAN-MACHINE MIX AT FIELD FORECAST OFFICE

Assuming that within the next five years NWP developments will result in approximately a 100% machine output of meteorological products by NMC, what will these products be, and what impact will they have on the man-machine-mix operation in the field forecast office?

First, it seems logical to assume that global models using smaller mesh lengths or some type of spherical harmonic analysis will be developed to improve the accuracy of present predictions and to add more detail to flow patterns. Availability and operational use of SIRS and IRIS satellite data, planned for FY72, should supply data necessary to support these finer mesh global NWP models (see Figure 10).

Second, as meteorological predictions improve with such models, the demands for weather service on field forecast offices will increase. These demands for the most part will be for forecasts of details and parameters that we are not likely to get from the computer; or if we could get such forecasts from the computer, they are not likely to be timely. Also, using a computer may not be an efficient way of performing this weather service. For example, it is difficult for me to see how NMC computer products can handle the small-scale short-period forecast, including both routine and severe weather phenomena such as squall lines, heavy snows, etc. Also, radar observations will certainly make manual input to such weather service important in the foreseeable future.

I think that there is evidence to support this point of view in the recent studies of predictability by Robinson [2] and Lorenz [3]. Weather phenomena have characteristic scales or dimensions in space and, similarly, they have typical periods and durations in time. It turns out that a large number of the significant weather occurrences of importance to the public are of a fairly small scale and relatively short duration. The squall line that recently caused so much trouble in Cleveland is a case in point.

It has been known for some time that smaller scale phenomena are generally less predictable than larger scale systems, and Robinson and Lorenz have shown a rather direct relationship between scale and predictability.

Figure 11 illustrates their general findings in the form of a predictability diagram. The ordinate is forecast period or length of the prediction, and the abscissa is the space scale which the forecast is to resolve. For scales and forecast periods lying below and to the right of the cross-hatched zone, theory suggests that deterministic prediction is practical in principle. The cross-hatched area lying above and left of the zone contains periods and scales which must be regarded as predictable only in a statistical sense.

The general pattern suggested is: clouds and precipitation produced by disturbances of the order of 10 degrees latitude in wave length are predictable by deterministic methods for periods up to 1 to 2 days in advance. The convective shower, representing a cell of very heavy precipitation triggered by the larger disturbance, may be predicted deterministically for periods up to 30 minutes and probabilistically for as long as the large-scale system can be predicted.

If the above analysis is correct, it is obvious that deterministic predictions of weather elements and systems that are required for reliable local weather forecasting are limited in time range.

Further it suggests that with the network data processed by the computer now and in the future, and relatively limited capacity of computers expected to be available in the 70s, we should not expect much help from NMC within the 6 - 12 hour forecast period. Our efforts then should be directed, as advocated by Roberts [4], to having the local forecast office develop conditional climatological studies relating computer-produced forecast parameters to specific user problems. I think such conditional climatology studies are needed for general public forecasts to take into account orographic effects in western United States. This reasoning also applies to terminal forecasting. Attempts at automating aviation terminal forecasts over the past ten years have been characterized by little or no success, and there is no reason to believe that there will be much success in the next five years. As a matter of fact, the Weather Bureau is considering curtailing efforts in this area because of the low probability of success in the next several years [5].

The computer should be making some inroads into station operations that will increase the quality of weather service currently given. At a recent Weather Bureau conference, it was suggested that we work toward linking several of the larger forecast offices to the computers at NMC [6]. With such a link, a station could request machine plots of the latest data, possibly every hour, for detailed analysis by station forecasters, or an evaluation of several objective studies, the results of which could be flashed to the local forecaster. This latter capability could be an important step forward since there are many useful studies available, but timewise it is impossible for a forecaster to evaluate them during preparation of an operational forecast. Consequently, he uses only those studies that can be applied quickly to phenomena that he has thought about. When the computer can compute all of the studies for him, there is less chance that an important facet of the weather, such as canyon winds, first snow of the season, etc., will be overlooked. Another important operation that this computer link will permit is hourly screening of terminal forecasts. As each hour's data come in, the computer can evaluate the unexpired portion of the existing terminal forecasts by use of conditional climatologies, and/or those few local terminal studies that may be helpful to "red flag" those forecasts that may be going "bad" in an hour or two. Such use of the computer should provide more timely amendments and reverse the usual procedure of issuing amendments after the forecast has "busted" rather than before.

As far as Weather Bureau operations go, message composition by use of a computer and CRT tube certainly seems to be a strong possibility in the near future. There is a procedure whereby you compose, revise, rearrange, etc., a written meteorological release on a CRT tube; and once you are satisfied with it, you push a button and it is disseminated. This eliminates using a typewriter or preparing a transmission tape. I understand a test of this type of procedure was begun at Suitland early this July.

I think one of the big manual efforts in preparing final weather forecasts will come through use of data from geostationary satellites. It seems reasonable to expect by the middle 1970s that at least in larger Weather Bureau and AWS forecast offices we shall have what I call Satellite "Instant Replay" capability. By this I mean the forecaster has satellite receiving equipment which will permit him to study time-lapse movies of cloud changes in his area of interest that have taken place over the past 3 to 24 hours. This is similar to the operational film-loop technique being tested at NMC and NESG presently, and which is covered in part by Mr. Oliver's presentation.

This opportunity of studying cloud changes in some detail in real time will be especially helpful in preparing short-range forecasts and will lead to a better understanding of existing conditions at the time the forecast is being prepared. This conclusion is based on my belief that short-range forecasting presently is more a diagnostic rather than prognostic problem. In light of previous comments on predictability of the atmosphere, it also appears to me that short-period forecasts up to 12 hours will continue to remain more diagnostic than prognostic problems.

Although the computer will greatly assist the local forecaster in processing data, etc., [7] it will take a man to be responsive to users' versatile requirements. I envision the computer making only modest inroads on applied forecasting procedures at field stations through the 1970s (see Figure 9). While the manual input of forecasts and forecast guidance issued at NMC should gradually decrease to near zero, the role of man at the forecast office will



remain paramount. His role will change gradually from one of evaluating centralized NMC predictions to one of accepting this guidance and adapting it to meet local area user requirements. This service-oriented role of the meteorologist--if trained both psychologically and academically for this job--should be challenging and rewarding. While the guidance he gets will not be perfect, it will be much improved over current guidance (see Figure 10) and will result in much improved man-machine-mix applied forecasts.

The 1970s will be a "Golden Decade" for the operational forecaster, who will work in a more professional and scientific environment, and who will receive more job satisfaction than he has ever known in the past.

#### REFERENCES

- [1] E. D. Diemer - Personal Communication dated April 10, 1969.
- [2] G. R. Robinson - "Some Current Problems for Global Meteorological Observations and Experiments", Quarterly Journal of RMS, 1967. Vol. 93, Pages 409 - 418.
- [3] E. Lorenz - "The Predictability of Flow Which Possesses Many Scales of Motion". Manuscript of scientific report by Massachusetts Institute of Technology, 1969.
- [4] C. F. Roberts - "Improving the Utility of the National Weather Service Within the Framework of the New Forecast Organization", Unpublished U. S. Weather Bureau Manuscript, 1969.
- [5] "Techniques Development Laboratory" - Monthly Progress Report - U. S. Weather Bureau, May 1969.
- [6] "Report of the 1969 SSD Conference - April 28, 29, 30, and May 1" - Compiled by the U. S. Weather Bureau Technical Procedures Branch - May 1969, Pages 18 - 21.
- [7] E. M. Carlstead - "Thoughts on Man/Machine Mix in Weather Services", Personal Communication dated June 2, 1969.
- [8] C. F. Roberts et al, "Report on Weather Bureau Forecast Performance 1967 - 68 and Comparison with Previous Years", ESSA Technical Memorandum WBTM FCST-11, March 1969, Pages 33 - 44.

# APPLICATION OF MODELS TO FORECASTING SENSIBLE WEATHER<sup>1</sup>

Carl W. Kreitzberg  
The Pennsylvania State University  
and  
National Center for Atmospheric Research<sup>2</sup>

## Abstract

Effective reasoning, analysis and communication regarding natural phenomena require the use of models to render tractable the complexities of nature. The operational meteorologist is responsible for the intelligent use of a variety of types of models. This paper attempts to put into perspective the proper roles of the different types of models to maximize the effectiveness of their utilization.

The types of models discussed include: descriptive or synoptic, dynamic or analytic, numerical or physical, statistical or optimized. The uses of models discussed include: education of basic concepts, research or experimental, operations or customized. The future roles of models in operational forecasting of sensible weather (clouds and precipitation) is discussed along with the impact of the organizational structure of weather services on the effective use of models.

In anticipating developments during the 1970's, it is concluded that probability forecasts of clouds as well as precipitation will become commonplace and will utilize a variety of statistical tools. Special purpose computer models will be available to many applied meteorologists by means of remote input-output devices. Data and forecast communication will be improved to provide closed circuit television displays of the latest digitally processed radar and synchronous satellite data as well as motion picture presentation of past and predicted weather and weather chart patterns. Studies involving systematic numerical experiments and a trial mesoscale forecast project will delineate the relative importance of the factors influencing sensible weather and determine the extent to which they can be forecast. Special observations and diagnostic models will evaluate the suitability of situations for operational weather modification.

Substantial improvements in sensible weather forecasting will require a concerted joint effort on the part of researchers from many organizations. The potential improvements will not be realized during the 1970's unless the customers and the operational weather services place strong requirements upon the research community to join the applied meteorologists in the necessary interagency effort.

-----

"We form for ourselves images or symbols of external objects; and the form which we give them is such that the necessary consequents of the images in thought are always the images of the necessary consequents in nature of the things pictured." H. Hertz (1894).

-----

1. This work was supported in part by National Science Foundation GA-1595.
2. Visiting Scientist at the National Center for Atmospheric Research which is sponsored by the National Science Foundation.

## I. Introduction

The above quote from the introduction to Heinrich Hertz's book is reputed to have been a favorite of V. Bjerknes (Godske et al., 1957). Such an exacting concept of models is too restrictive and Godske in his general introduction to the summary of classical Norwegian meteorology (Godske et al., 1957) provides for approximate models of either descriptive or theoretical nature:

"Owing to the complexity of atmospheric phenomena, in many cases we cannot arrive at models which can be treated by mathematical methods and at the same time give a sufficiently correct picture of atmospheric conditions. We must, therefore, introduce two different kinds of image or model; we shall call them dynamic models and synoptic models. Dynamic models are obtained by simplification from the fundamental equations of motion characteristic of the atmosphere, and can be discussed by mathematical methods. Synoptic models, on the other hand, are obtained by simplification of the complex motions actually observed on weather maps; although they cannot be discussed in a way that is entirely satisfactory from the theoretical point of view, they must always be chosen so that their general study is based upon sound physical principles. The two types of model will, in due time, approach each other, and lead to dynamic-synoptic models. Some of the models applied today are probably not very far from that state of perfection."

The operational meteorologist is sometimes disturbed by the contrast between the simplified synoptic models he sees in the textbooks and the complex systems he sees on the weather map. He is even more unnerved by the neglect of what he believes to be fundamental physical factors in the dynamic models he is asked to consider. He realizes that approximations are necessary to make problems theoretically tractable but he is unsure as to how applicable the results will be to real situations. Sutcliffe (1952), in his excellent review of synoptic weather forecasting, considers the advantages and limitations of synoptic models and concludes: "There is little doubt but that each model describes a type of dynamical evolution which is in a sense self-contained and tends to carry through according to type once initiated. There is also no doubt that the study of such models is of real practical value, but it is also treacherous. Once a forecaster visualizes a model he is in danger of being blinded to any other possibility and may even disregard direct pointers, even obvious tendencies, which do not support his picture."

Scorer (1968), in discussing air pollution and models warns that theories, models and formulae are not generally applicable and cannot be because of the complexities and varieties of atmospheric situations. Thus, he emphasizes "...seeing the mechanisms in action so that one can quickly learn from eye observations what happens with a greater quantitative precision than by theoretical formulae." He warns "...it is always naive to choose the form an answer will take before an investigation is complete, and it is now widely appreciated that the formulae are valuable mainly in helping the inventor or user of them to appreciate more clearly the origin of the endless variety of situations we find."

The justification for simplification in modelling is supported by consideration of the nature of facts (Chorley et al., 1957). It is pointed out that particular events are all different but common characteristics exist which provide an orderly basis from which to approach another particular event. Furthermore the importance is stressed "of seeking for relevant pattern and order in information, and the related ability to rapidly disregard irrelevant information." Quoting Van Duijn (1961), "It is the capacity for pattern-seeing and not the actual surveying of the landscape which explains this rapidity" (of scientific development).

Whether, and to what extent, a model should be "believed" or used is discussed from the operational standpoint by Skilling (1964). He feels that a model has a particular probability of being correct and a finite range of applicability. When to use a given model is to be determined from common sense plus the "trial by fire" of experience in its operational performance. Then he summarizes with the opinion that "...one can do no better than to believe what he believes it is good to believe."

The point is that modelling is an essential tool of science and the operational meteorologist is faced with the responsibility of comprehending the significance of a variety of types of models. Not only are there the synoptic and dynamic models in the previous quote from Godske, but there are a multitude of numerical models and statistical models. Furthermore, the nature, role and, hence, the applicability of models depends upon the use for which they are designed. "Textbook models" usually are designed to clearly convey a basic concept

rather than a complete natural event. Research models are designed to evaluate specific factors under very special conditions. Operational models try to be realistic but they are restricted by data and time limitations and are tailored to provide answers in the form desired by certain customers.

The organization of weather services will have a decisive influence upon who will receive special training and will then have the opportunity and responsibility for properly utilizing different types of operational models in the coming years. Educational and research models will provide the basic knowledge and understanding of the atmosphere necessary for professional performance in the field of applied meteorology.

Certainly the task of forecasting sensible weather during the 1970's will require the use of numerous new models of various types. The purpose of this paper is to put into perspective the proper roles of the different types of models to maximize the effectiveness of their utilization. The discussion will be organized as shown in Fig. 1. The characteristics of the different types of models will be contrasted; the influence of the intended use on models on the way in which they can aid or hinder the applied meteorologist will be discussed; and the availability of operationally useful models will be considered in terms of the organizational structure of weather services. The sub-titles in the classification scheme are intended to reduce the inherent ambiguity in the types of models to be included in the different sections.

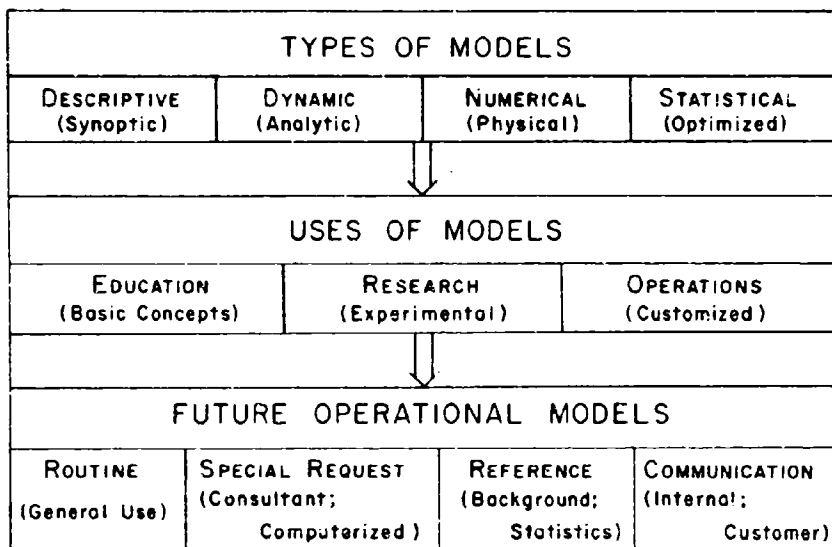

Figure 1. Organization of models and topics as discussed in this paper.

## II. Types of Models

a. Descriptive (synoptic) Models. The descriptive model is basic to synoptic meteorology as it provides a simplified view of an ideal weather system with a substantial amount of physical consistency. These models are used to obtain a three or even four-dimensional feeling for how the atmosphere is organized. Such models are extremely useful for constructing reasonable analyses in greater detail than the limited observations will permit from an objective standpoint. With the model in mind the analyst can disregard "unrealistic" data thereby filtering out both data errors and small scale features that cannot be adequately resolved. Frontal model analyses also call attention to those general regions in which the weather may be active.

The classical frontal models include the distribution of sensible weather elements (clouds and precipitation). These patterns are much less complex than any individual storm

and are representative of the climatological mean distribution. For example, the frequencies of different types of weather in 14 different sections on a time section through an occluded frontal system were computed by Kreitzberg (1964) from a sample of 24 cases. The results show that a model consisting of the most frequent event in each of the 14 sections of the storm was essentially identical with the Norwegian model (Godske *et al.*, 1957). However, the probability of a particular storm resembling the most frequent model in all 14 details was less than 1% and resemblance in the 6 grossest details had a probability under 14%.

While one could worry about how well different synoptic models work in different parts of the country, the essential fact is that the model can depict no more than the mean condition with the variable features filtered out. As such, the model provides the forecaster with a first guess based on synoptic climatology. The challenge to the forecaster is to utilize knowledge of local conditions and observational data for a particular storm to predict the departure of events in this particular storm from the synoptic climatological first guess. The model also serves the important function of providing an orderly basis from which to approach a particular event.

Another type of descriptive model is that which is designed to clearly portray the essential features of a particular process or type of weather system. This type of model serves an educational function but does not provide the optimum first guess field unless the situation is clearly dominated by the particular process or system modelled.

The roles of the two types of descriptive models, the mean system versus the special system which may or may not be frequent, are very different and the operational meteorologist must not confuse them.

b. Dynamic (analytic) Models. These models reveal how different quantities or parameters are interrelated and how particular processes will operate in response to the laws of nature. Also, mathematically formulated models make up for their obscurity to the non-mathematician by using the deductive power of mathematics to reach conclusions that could not be reached otherwise.

Since these models must be very specific they avoid the ambiguity and vagueness that often plagues the descriptive models. The reverse side of this coin is the narrowness of dynamic models that results from the requirement that they be specific. For dynamic models to be tractable to their developer and, as importantly, comprehensible to their user requires that they deal with highly simplified conditions.

It is important that the applied meteorologists recognize the positive aspects of dynamic or theoretical models rather than rejecting them because they are oversimplified in their assumptions. The potential user should accept the contribution to a deeper understanding of a specific process that such a model provides instead of ignoring piecewise advances and asking for complete solutions.

There are varying degrees of "dynamics" included in theoretical (and numerical) models. Most models restrict the dynamic interactions that they allow. Kinematic models take the wind field as given. Particle dynamic models take the pressure field as given and predict motions. Some models take diabatic heat as given while others diagnose diabatic heating as a function of the predicted developments. Very few models predict surface (ground) temperature and moisture but rather these conditions are prescribed.

Many models can be interpreted as consistency analyses. The more obvious conditions are specified and less obvious implications are deduced from requiring correspondence to basic laws. For example, if hydrostatic balance is specified, then one can diagnose the vertical velocities that must occur to maintain this balance. If quasi-geostrophic balance is specified, then too certain vertical motions can be deduced to insure maintenance of the thermal wind equation, for example.

Oftentimes more can be learned from more restrictive models because it is clearer why the results come out as they do. The researchers are more likely to appreciate the contributions furnished by highly restrictive models. Unfortunately, the applied meteorologist rarely has access to information from these models in a concise, intelligible form to permit his physical understanding to steadily improve with the scientific advances.

c. Numerical (physical) Models. Numerical models, backed by electronic computers, provide quantitative results which may be either quantitatively correct or only qualitatively correct. The need in sensible weather forecasting to rapidly deduce complex processes in view of large quantities of observational data makes numerical models essential to future improvements.

Numerical models are adapted from dynamic or physical considerations but certain physical processes are "parameterized." Parameterization is an outgrowth of the method of coefficients discussed by Scorer (1958). In the method of coefficients, one deduces theoretically that two quantities are proportional but the proportionality coefficients are deduced from experiments (just as specific heats and latent heats are determined without resort to microphysical theories). In numerical modelling with finite grid spacing, the problem of modelling physical processes is compounded by the absolute inability to resolve scales less than twice the grid interval and the practical inability to resolve scales less than four or more times the grid interval (due to the problem of non-linear instability). Thus the model must have the effects of small scale processes expressed in terms of large scale parameters. This parameterization may achieve only a rather crude estimate of the small scale influences.

In numerical integration of the forecast equations, control of truncation errors<sup>3</sup> often requires the use of grid intervals much smaller than would seem necessary to resolve the scale of features present in the model at a single time. Thus, the observation spacing dictates the appropriate grid spacing for the analysis model used to establish the initial conditions, but the forecast model may use a much higher resolution grid just to improve the forecast of large scale features.

The practical problem of observing conditions that control sensible weather developments is to some extent insurmountable. This difficulty is true even for many research purposes where real time forecasts are not necessary. Thus many research models will utilize synthetic data to deduce the developments that result from hypothesized initial conditions. The operational value of studies with this type of model arises from the increase in knowledge of what sort of systems the atmosphere can generate in view of physical laws. These studies will delineate factors that are important from factors that are inconsequential. These studies will also show what observations are essential for predicting certain events and, therefore, which events cannot be predicted without prohibitively expensive observations.

The problem of providing the operational meteorologist with the results of numerical models, either specific results or generalizations from a series of numerical experiments, will be deferred until the discussion of future operational models.

d. Statistical (optimized) Models. Since observed sequences of events are recorded in our climatological data banks, it is reasonable to think that statistical methods and electronic computers could be used to empirically relate weather elements to preexisting conditions. The preexisting conditions could be either individual weather elements or sets of weather elements or objectively defined synoptic systems or analogues. See for example T. F. Malone in Petterssen (1956) or Christensen and Bryson (1966). Techniques are available to rapidly seek out the best set of predictors of an event from a large sample of possible predictors.

Such statistical methods can succeed where physical understanding is completely lacking. The results of statistical studies can provide clues to physical understanding just as physical understanding can be a power tool for properly framing the statistical problem by suggesting possible predictors and the forms that statistical relations should take. In any case, if a statistical model works it can be used in spite of lack of understanding of why it works until some better technique is developed.

In prediction of events that are effectively non-deterministic from available data or in predicting the integrated effects of large numbers of events, statistical models offer the only solution. Statistical models can be used to predict the probabilistic structure<sup>4</sup> of the response of some system to forcing functions for which only probabilistic structures are

3. These truncation errors are the result of approximating gradients at a point with finite differences.
4. By probabilistic structure is meant the appropriate statistics that summarize the variations; such as means, standard deviation, variance, etc.

known. Many engineering problems require knowledge of the expected range of weather events or probabilities that certain extreme events or a combination of events will occur during a certain time interval. For such problems statistical models are not only the only practical models but they are often very powerful.

Statistical methods play an important role in objective analysis techniques and in objective synoptic climatology studies. Statistical models are also used in the development of parameterization schemes in numerical models where one needs to know information on the statistics of the unresolvably small systems.

On the other hand, disadvantages of statistical models arise from their lack of physical basis. It is difficult to systematically gain physical insight by studying the successes and failures of different predictors. When an objective forecast scheme is developed for one location, there is no way to directly apply it elsewhere because the predictors need not have a direct relation to universal physical laws. The necessity for deriving special objective forecast equations for each site is no problem when digitized climatological data are available but it is difficult to deal with new sites that lack an extensive data record.

It is also difficult to integrate objective (statistical) forecasts with dynamic or subjective forecasts because the source of the statistical skill may or may not be independent of the source of the dynamic or subjective skill. For example, if the forecaster subjectively anticipates an event and the statistical model concurs, how does the forecaster decide if two independent techniques are predicting the event thereby giving a higher confidence of verification?

The psychological side effect of relying on an uncomprehensible statistical model is bad because if nature appears to be uncomprehensible we are tempted to turn forecasting over to persistence probability tables, or something similar, and abandon rational physical scientific development. Much is said about the complementary nature of dynamic statistical methods. Certainly they both have their proper roles and the ideal is an integration of dynamic and statistical models as needed within a rational physical framework. In the meantime the successes of statistical models will serve to prod the physically oriented meteorologist into improving his knowledge so that physical models can be developed that will explain or surpass the statistical ones.

### III. Uses of Models

The proper interpretation of a model requires consideration of its designed use as well as its basic type. The applied meteorologist can benefit from educational and research models so long as they are not confused with operational models.

a. Education (basic concepts) Models. Introduction of new concepts requires that their essential elements be outlined in simple, clear, idealized examples. Educational or textbook models are designed for this purpose. For example, zero-order frontal models, in which a frontal surface separates two different air masses each of which is uniform, is excellent for initiating students to frontal theory. In practice, however, the first-order frontal theory is far more applicable wherein the temperature gradient is concentrated in a frontal zone of finite width with the warm boundary defined as the frontal surface (Godson, 1951). In reality and in the first-order theory, fronts need not slope toward the cold air and whether occlusions have a warm or cold slope is independent of the relative coldness of the preceding and following air masses (Kreitzberg, 1964). Such operational weaknesses in elementary models do not mean that elementary models are "wrong" and should be deleted from introductory textbooks; it means that more advanced models must be applied when elementary models are not applicable.

The requirement that formal education prepare students to adapt to developments in the five or ten years after they leave school means that courses concentrate on a wide range of fundamentals instead of currently popular operational models. Also books and particularly textbooks have two or more years lag time between selection of material and publication. Therefore it is unrealistic to expect even advanced courses or texts to contain the optimum models for operational purposes. Educational models do provide the background knowledge upon which the applied meteorologist builds his facility with current operational techniques.

b. Research (experimental) Models. Research models yield results that expand the applied meteorologist's background to include specialized topics and more recent developments than educational models. The specialized nature of these models means that they usually deal with a small part of the applied problem. The current and experimental nature of these models means that the results are more tentative than either educationally adapted or operationally tested models.

Research results are often not published in the form the applied meteorologist would like; the style is usually too formal and brief; the models are not designed for real time general use; the form of the input parameters and the type of output quantities may be unfamiliar to practicing meteorologists. There is a need, therefore, to have someone rephrase the model results so that groups with operational requirements can pass the information on to their meteorologists in the field.

c. Operational (customized) Models. These models are usually tested with many cases and then tailored to accept operationally available input parameters, to produce the most readily used product within an acceptable amount of man and/or computer time, and to disseminate and display the product in the optimum form at the correct time.

These models can become custom tailored to the point that they are very difficult to entirely understand. The basic principles and physics of the model are often easier to decipher from explanations of an earlier stage of the model. It is essential that checks be performed and documented to show what changes in basic principles, physics and accuracy are introduced during development of the operational version of the model.

#### IV. Future Operational Models

In speculating about the role of models in sensible weather forecasting in the next decade, developments that appear to be technically feasible will be discussed first. Consideration will then be given to which of the potential developments are likely to be realized in view of funding requirements and the organizational structure of the weather services.

a. Routine (general usage) Models. The sensible weather in global long range models will be treated so as to yield the proper dynamic effects in the model rather than to provide directly useful sensible weather forecasts. Therefore climatological rather than meteorological results will be obtained either by judicious parameterization or by direct specification. Intermediate range forecast models will predict clouds as well as precipitation dynamically and will provide confidence limits or probabilities statistically.

The shorter term forecasts will be based on fine mesh models which will output trajectories as well as sensible weather forecasts. The trajectories will then be used in the field to infer cyclonic scale effects on observed mesoscale developments thereby updating and refining the cyclonic scale forecasts. Routine short term forecasts will utilize communication advances, the increased physical understanding of the meteorologist, and statistical models for accounting for the routine effects of local topography.

b. Special Request Models. Since many important forecast problems arise infrequently, special models will be made available upon request only. The request may go to a specialized consultant or may be handled by remote input-output access to time-sharing computers. This computer will have libraries of special purpose dynamic, kinematic and statistical models as well as access to computers that process the current data and forecasts. Special requests for long range probability forecasts will be forwarded to specialized consultants who will generate the answer by computer processing of climatological data and possibly modify the results in view of other long range forecast techniques.

Meteorologist-customer relations will become more intimate as highly specialized problems are attacked. The meteorologist will understand his customer's problem and will tailor his product to meet the requirement. The customer will understand how to use the product and why more detailed answers and narrower confidence limits are unavailable. Because of the effort and cost of such services, only important problems and key decision makers will receive these services and directly or indirectly pay for them.

As operational weather modification becomes more common, more specialized services and instrumentation will be devoted to evaluating the suitability of conditions for modification.



To make a significant attempt toward substantially improved mesoscale and short term or detailed forecasts will require a special test project. Such a project was recommended by an ad hoc group established in March 1966 by the Interdepartmental Committee for Applied Meteorological Research (ICAMR). The ad hoc recommendation is summarized and expanded upon by a full-time task team (ICAMR, 1966). Such a project will delineate the relative importance of factors influencing sensible weather and will demonstrate the extent to which detailed forecasts of sensible weather are possible.

c. Reference (background; statistical) Models. These models include relevant educational and research models adapted as background material for the applied meteorologists. Descriptive models will realistically combine empirical models with physical explanations and will stress the relative importance of different factors depending upon the circumstance. Results of controlled numerical experiments with systematically changed conditions will show the sensitivity of sensible weather development to initial conditions. The results will be organized to show what parameters are critical under certain circumstances as well as what range of possible outcomes can occur within the limits of the initial observations.

Reference models will also include statistical probability tables on a climatological basis, under different synoptic conditions and under different initial conditions (persistence probability). Model results showing effects of localized conditions, such as height, slope and vegetation, will be used to permit the applied meteorologists to roughly extrapolate from more general forecasts to very specific forecasts. Certain more general corrections for localized conditions will be produced upon request from the computer terminal.

d. Communication Models. Efficient data processing, communication and display techniques will continue to be essential for an efficient weather service and for improving the quality and usefulness of short term forecasts. The current use of remote display of radar data on a television set will be expanded to include the latest digitally processed radar and synchronous satellite data. Furthermore, motion picture presentation of past and predicted weather and weather chart patterns will provide an efficient and dynamic form of weather briefing for the meteorologist and the experienced customers.

The form in which the customer is provided with weather information is critical to its usefulness. Improvements to come will include not only specialized forecasts but specialized and oftentimes computer generated forecast formats.

e. Impact of Task Priorities and Organizational Structure. Having viewed the technically feasible, we now shall consider the realistically probable developments. Where needs are greatest and where financial support can be obtained, the advances can be achieved but they will be costly. Customer demand will be for improved storm, severe weather and terminal forecasting and for specialized services. Applied researchers will press for support in numerical modelling and a trial mesoscale forecast project. Highly skilled personnel will seek the challenging jobs where efforts are underway to make substantial improvements.

To implement these improvements will require that weather services challenge their meteorologists with varied specialized forecasting tasks. The personnel must be provided with the educational and training programs necessary to update their understanding of physical processes, knowledge of new models and techniques, skill in applications and communication with the customer. Persons not receiving advanced training will assist the professionals and will communicate the information to the general customer.

Provisions will have to be made for the customer to obtain specialized services either from a general or a specialized consultant. The meteorologists will require access to specialized consultants, specialized information and a computer terminal linked to computers with specialized programs on call. In line with Scorer's (1968) emphasis on the value of "...seeing the mechanisms in action..." it will remain essential for the meteorologist to be personally familiar with the problems he advises on and not become isolated in the weather central to which he is assigned.

## V. Summary and Conclusions

Modelling has historically been an essential tool of science for rendering tractable the complexities of nature. More recently numerical and statistical models have been added to

the familiar synoptic and dynamic models. Sutcliffe (1952) has warned that models can be treacherous in wooing the forecaster into a feeling of comprehension before the data have been adequately considered. Scorer (1968) notes that models are very narrow in scope, they can be applied only after careful examination of the situation, and they lead to an appreciation "...of the origin of the endless variety of situations we find." The operational meteorologist has the responsibility for the intelligent application of the variety of types of models discussed in this paper. To fulfill this responsibility in the face of numerous new models that are not necessarily tailored to his desires, the applied meteorologist must continually update his training and properly understand the potential roles of these models.

Descriptive models combine in a simplified but clear fashion the essential characteristics of atmospheric structures and processes as deduced from both empirical evidence and theoretical reasoning. Dynamic models utilize powerful methods of mathematical deduction and capitalize upon the obedience of nature to basic physical laws to provide a firmer understanding of specific phenomena.

Numerical models of physical processes permit quantitative evaluation of a wide range of events. Indeed, they can reveal details that cannot be directly or accurately observed. Much remains to be done in communicating the results and implications of numerical experiments to the applied meteorologist.

Statistical models are essential for the specification of confidence limits on forecasts to increase their usefulness. Statistical methods can also treat phenomena that lie beyond the scope or outside the province of deterministic physical models. The integration of statistical and dynamic models within a rational physical framework is as important as the integration of synoptic and dynamic models.

In interpreting a model it is important to consider the principal use for which it was designed. Educational models frequently introduce or stress one factor or concept and are more schematic than realistic; their intent and therefore their role is to provide a background of basic concepts. Research models are often highly specialized to examine the role of a specific mechanism which may or may not be the dominant mechanism in a real situation. Only by patiently accumulating and integrating knowledge from a number of specific models can a person interpret a complex situation and understand the dominant factors in that particular situation. Operational models have been adapted to data and manpower limitations which can blur their physical basis. The output is tailored to meet certain user requirements and communication limitations and the result may be a compromise between the desires of different users.

Future models used by applied meteorologists will be a compromise between the technically feasible and the practically realizable. Where the problems are more urgent and the funds more available, progress will be more rapid. Routine numerical models will become more detailed as modelling and computer technology advances. Subsidiary output such as trajectories and probabilities will become more common. Improvements in communications, physical understanding and statistical inclusion of local effects will improve short term detailed forecasts.

Substantial improvements can be anticipated from the use of specialized models as special situations arise. Remote access to time sharing computers and to specialized consultants will greatly augment the capability of the field forecaster. Giving special, personal attention to special user requirements will increase the accuracy and the utilization of specialized information, assuming the needs or the funds of the customer permit such special consideration. Operational weather modification programs, for example, will require special attention to determine the suitability of the techniques and conditions for weather modification. A special test and evaluation project should be established to demonstrate the potential for sophisticated mesoscale forecasting.

Reference and background material must be provided to the applied meteorologist so that he may gain physical understanding from improved educational and research models. Materials should be available to adapt a more general forecast to local influences at a specific spot. Results of systematic numerical experiments should show the dominant factors in different situations and the range of possible outcomes from initial conditions defined within the limit of available observations.

Communication advances will permit graphic transmission of digitally processed radar and synchronous satellite data and the dynamic (motion picture) display of weather maps and forecasts. Customers will receive information in clear and graphic forms tailored to their needs.

These improved models and techniques will challenge the meteorologists to keep up to date in specialized areas. The weather services will have the responsibility for providing the necessary training and a stimulating work environment that will permit special consideration to be given to special problems. Field personnel must have access to special computer models and to specialized consultants. Customers too must have information on and access to special services.

There are many challenges and opportunities facing the research community in addition to the needs of operational meteorology. It is very possible that the field forecaster and his customers will not see the potential advances discussed in this paper realized in the 1970's. The system managers may concentrate on advances that can be implemented by machines and phase out the forecaster instead of supplying him with the training and research support necessary for him to realize his potential. Should this result be permitted to occur, the core of the meteorological profession and the customer of specialized sensible weather forecasts will go unserved by science as automation will provide demoralization rather than inspiration. The highly educated scientists, the system managers and those customers who need only the computer products will then be the only beneficiaries of the machine age.

#### Addendum: Development of Man's Role in Weather Forecasting

A preoccupation with utilization of advanced machine technology and long-range forecasting dominated plans for operational meteorology in the 1970's presented at the 1969 Meteorological Technical Exchange Conference. However, short-term weather forecasting could advance markedly in the next decade if the necessary research and management support is provided to the forecaster. To insure that his is an effective, contributing role the individual forecaster must receive continuing education, access to special computer routines, and the time and responsibility for applying his knowledge to special forecast problems. Without support from research and management, the forecaster's morale will decline as his tasks become more mechanical, qualified students with an interest in weather will be dissuaded from the forecasting profession and new scientific knowledge will not be put to use.

Programs have not been initiated that will fully develop the forecaster's ability to use his intelligence to exploit scientific and technological advances. The challenge of rapidly incorporating knowledge of physical processes into forecasts of a wide variety of special phenomena under a wide range of poorly defined conditions requires utilization of a highly motivated person supported by optional mechanical aids. Certainly a mechanized forecast system is easier for the system designer to program and the system manager to manage, but can the user afford the loss of a compassionate man's ability to deal in a physically realistic manner with innumerable special problems?

This addendum is a plea for consideration by the research and management communities of the needs of the short-term weather forecaster and the users of such specialized forecasts. Plans are outlined for an interagency effort to furnish the research, development and training needed to realize the potential advances in short-term forecasting. This program would stimulate the field forecaster, attract highly motivated and qualified students to the field and supply the customer with the services that advances in science and technology can support. The importance and magnitude of the task and future funding limitations, necessitate achievement of complete interagency cooperation.

It is proposed that the National Meteorological Application Center, as outlined in Fig. 2, be established to rapidly expand and implement knowledge of small scale and sensible weather phenomena. This center would be directed by a board composed of representatives from interested agencies, universities and industries to provide financing and establish priorities. The center would be staffed by a permanent cadre of meteorologists and supporting personnel. Agency coordinators and task teams would work at the center utilizing its facilities to solve problems peculiar to that agency. Special joint programs and tasks of limited duration would be conducted by the center. Visiting scientists would work with the center, contributing and broadening their knowledge in specialized areas. Summer programs would expose and enthuse students with the latest methods and challenges in weather forecasting. Operational

meteorologists would receive advanced training in operational forecasting techniques from a continuing series of short courses at the center and correspondence courses, briefing teams and training aids sent to weather stations. In essence, the center would develop and maintain the up-to-date Compendium of Applied Meteorology in loose-leaf format.

#### NATIONAL METEOROLOGICAL APPLICATION CENTER

Science - Mesometeorological Research Organization  
+  
Technology - Technique Development and Evaluation Program  
+  
Education - Advanced Operational Techniques Institute  
"  
Progress - Doing what can be done together.

Figure 2. Outline of the proposed interagency organization to advance short-term and small-scale weather forecasting.

The Mesometeorological Research Organization would conduct field programs and do applied research. Such an organization has been recognized by several planning commissions in past years as essential for significant advances in mesometeorology (ICAMR, 1967). Unfortunately, the agencies have not agreed upon a program suitable to all their needs and within acceptable budgetary limitations. As part of the Application Center, the Research Organization would contribute directly to operational technique development.

The Technique Development and Evaluation Program would tailor scientific and technological advances for operational implementation. This program would utilize computer-to-computer communication with the operational data bank, forecast, and climatic center computers. Forecast techniques could, therefore, be used on an experimental basis in the operational environment until their weaknesses are removed and their value proven. Proven techniques would then be passed on to the operational forecasters through the training institute.

The Advanced Operational Techniques Institute would have the flexibility required for providing instruction in the latest specialized techniques. Completion of instruction would be accepted as evidence of mastery of the latest available operational information. The research, development and visiting personnel would all participate in the instructional program and would be challenged and stimulated by the questions and ideas from the students, who would be the immediate consumers of the center's products.

Interagency participation is essential to provide an adequate manpower and financial base for the center and to permit maximum utilization of the products. Potential interagency contributions are very large and could be communicated continually instead of annually at the Technical Exchange Conferences. Many agencies face the same meteorological problems or problems that are physically inseparable. Future weather services will use common forecast systems as they now use common data collection systems. An interagency research, development and training center will hasten successful interagency forecast systems and progress will proceed at a rate that can only be achieved by doing what can be done together.

#### REFERENCES

- Chorley, R. J., P. Haggett (ed.), 1967: Models in Geography, London, Methuen, 816 pp.
- Christensen, W. I., R. A. Bryson, 1966: An investigation of the potential of component analysis for weather classification. Mon. Wea. Rev. 94, 697-709.
- Godske, C. L., T. Bergeron, J. Bjerknes, R. C. Emding, 1957: Dynamic Meteorology and Weather Forecasting, Amer. Meteor. Soc., Boston, 800 pp.
- Godson, W. L., 1951: The synoptic properties of frontal surfaces. Quart. J. R. Meteor. Soc. 77, 633-653.

- Hertz, H., 1894: Principles of Mechanics. Translated by D. E. Jones and J. T. Walley (1899). Reprinted, Dover Publications, Inc., New York (1956), 274 pp.
- ICAMR, 1967: Mesometeorological Research and Development Prospectus. Report to the Interdepartmental Committee for Applied Meteorological Research, OFCM-67-2, 42 pp.
- Kreitzberg, C. W., 1964: The structure of occlusions as determined from serial ascents and vertically-directed radar. Air Force Cambridge Research Laboratories, AFCRL-64-26, 121 pp.
- Scorer, R. S., 1958: Natural Aerodynamics, Pergamon Press, New York, 312 pp.
- Scorer, R. S., 1968: Air Pollution, Pergamon Press, New York, 151 pp.
- Skilling, H., 1964: An operational view. American Scientist 52, 388A-396A.
- Sutcliffe, R. C., 1952: Principles of synoptic weather forecasting. Quart. J. R. Meteor. Soc. 78, 291-320.
- Van Duijn, P., 1961: A model for theory finding in science. Synthese 13, 61-67.

## SURVEY OF PROGRESS AND PLANS IN TROPICAL METEOROLOGY EXPERIMENTS

Dr. Edward J. Zipser  
National Center for Atmospheric Research\*  
Boulder, Colorado

### ABSTRACT

Stimulated by the necessity for including tropical processes in the next generation of general circulation models, and also by the depths of our ignorance of such processes that satellite data have forced upon us, research in tropical meteorology is now accelerating. Some results from the Line Islands and Barbados Experiments are discussed, with emphasis on the role of sub-synoptic processes and on the need for fine vertical resolution in tropical data. The background of the proposed Global Atmospheric Research Program (GARP) is reviewed briefly. The current status of plans for the tropical part of that program is summarized, along with its main scientific objectives.

### I. INTRODUCTION

As I stand here, three men are traveling toward the moon in APOLLO 11. If all goes well, they will collect samples of lunar surface material and bring them back to earth, where they will be analyzed. And we can be completely confident that papers will soon thereafter appear in the literature on lunar composition, meteorite rate, origin and age of the moon and the earth, and theories of the solar system. This reminds me of tropical meteorology. The surface area of the moon is 12,000,000 square miles; there will be one data point in all of this area. That is about the data density over much of the tropics.

In all that follows, I will confine myself to the subject of tropical synoptic meteorology, with emphasis on the description of disturbances over the ocean, including sub-synoptic scale features and convection. I will not deal with hurricanes, climatology, or conditions over continents.

The research spurt in tropical meteorology in the decade following World War II was stimulated in part by the abysmal ignorance that so many pilots were forced to deal with, and especially by the new data that resulted from military presence in the tropics, both during the war and during the post-war bomb tests in the Pacific. During the next decade, research emphasis was shifted to tropical cyclones. But a second spurt has been gathering momentum for several years and should reach its peak during the 1970's if present plans are allowed to materialize. The cause of this second spurt is twofold: First, recent satellite data has been a strong stimulus by allowing us a useful look at all parts of the tropics including data voids, and this new look has revealed enough features that were unexpected that we are again face to face with our own ignorance; second, global numerical models will require direct incorporation of tropical processes for forecasts beyond a few days. It has become apparent to nearly everyone that fundamental observations and understanding of many tropical processes do not exist and will not exist without well-designed field experiments covering all scales of motion from turbulent to large scale.

### II. SUMMARY OF SOME RECENT TROPICAL EXPERIMENTS

a. Early Experiments. I cannot do justice to these early programs here. Several expeditions were carried out in the Caribbean and tropical Atlantic during the late 40's and the 50's under the auspices of the Woods Hole Oceanographic Institution, which were important pioneering efforts toward understanding more about sea-air interactions and convection. In 1963, a joint program was carried out near Barbados by Woods Hole and Florida State University where satellite and aircraft on cloud systems and disturbances was first combined with island and ship data on sea-air interactions. It is appropriate to note here that Dr. Lowenthal,

\*The National Center for Atmospheric Research is sponsored by the National Science Foundation.

USAECOM, and CAPT. Max Eaton, then of Fleet Weather Facility, gave important support to that program. Although limited in scope, it was this concurrent data sample on several scales that made the program valuable. This approach is basic in the field programs that followed.

b. The Line Islands Experiment. This program, conducted on and near Palmyra, Fanning and Christmas Islands during February-April 1967 produced a comprehensive sample of satellite, aircraft and surface-based meteorological data. A complete catalogue of the data obtained is available (Zipser and Taylor, 1968). The immediate stimulus for the experiment was the availability for the first time of synchronous satellite observations. Despite this space-age system, the restriction of this program to off-the-shelf items gave it a decided World War II flavor, as a glance at the pictures in the catalogue will reveal. I will mention two areas of progress resulting from this program.

(1) Wind structure in the vertical. During the Line Islands Experiment, rawinsondes were released at three to six hour intervals from the three islands. Data were recorded at two prints per minute and carefully processed for maximum possible vertical resolution. These serial soundings characteristically revealed strong wind variations in the vertical of small vertical scale. The 8-day period illustrated in Fig. 1 and 2 is fairly typical, and shows the u and v-components separately for the 6N island, Palmyra, and the 2N island, Christmas. The small scale features are seen at both islands and at all levels from the low troposphere through the lower stratosphere. But they are stronger in the v than in the u-component, stronger at 2N than at 6N, and stronger near the tropopause than at other levels. These features are confirmed by so many consecutive soundings that their reality cannot be in serious doubt. At one point, the v-component alone changes by  $45 \text{ m sec}^{-1}$  in just over 2 km. At the same time, the sign of the v-component changes some 8 or 9 times between the surface and the lower stratosphere.

These intense shears are significant in several respects. Consider the pilot on a cross-equatorial flight at normal jet-aircraft altitudes who is encountering  $20$  or  $30 \text{ m sec}^{-1}$  headwinds; he might very well find a tail wind by changing altitude by 2 km! Consider the current plans to obtain global data by means of constant-level balloons at, say, 200 mb, or by means of cirrus cloud motions from geosynchronous satellites. If this kind of complex wind structure is common in the equatorial zone, how can data at one or two levels describe the real situation? This wind structure is also of considerable scientific interest because they may be manifestations of gravity waves trapped in equatorial latitudes, which may be important agents of momentum transfer in the vertical (see e.g. Lindzen and Matsuno (1968)). And finally, those who are developing global numerical models can probably not afford to neglect these features. Obviously, there is ample motivation to learn as much as we can about them.

(2) Structure of some kinds of tropical disturbances. Of the many disturbances that affected the Line Islands during the field program, the most comprehensive data was gathered in the 1 April 1967 case. This case has been described in detail elsewhere (Zipser, 1969), so only the essence of the findings will be covered here. The cloud system associated with this disturbance developed almost explosively during the preceding night and decayed almost as rapidly during the daylight hours of 1 April, never to regenerate (Fig. 3). The evidence is clear that strong downdrafts developed as the cloud system developed, and that the downdraft air, originally dry middle tropospheric air, filled the system by early morning (Fig. 3b) and continued to expand behind the cloud arc seen in Figs. 3c-3e. This cut off the supply of high energy low-level air to the cloud system, which decayed rapidly as a direct result, since new cumulonimbus development could no longer continue its maintenance. The other key points are that the downdrafts are deduced to be highly unsaturated, and that the structure of the cumulonimbus aggregates producing the downdrafts is similar in most respects to that of mid-latitude squall lines (Fig. 4), with the added feature that the downdraft can be produced by mesoscale sinking under raining anvils as well as by convective scale sinking.

In a few minutes, evidence will be presented to show that this is not a unique weather system, but in fact a rather common occurrence. This finding takes on added significance when the results of a tropical cloud census made by the Study Group on Tropical Disturbances (Pisharoty, Fujita and Yanai, in a report to the Joint GARP Organizing Committee) are considered. In a study of tropical Pacific disturbed areas, they adopted the term "cloud cluster" to describe most synoptic scale cloud systems. They found that fully half of these cloud clusters, classified as the "oval" type, were characterized by lack of apparent wave or vortex structure and had typical lifetimes of one to two days. These are not the well-known easterly waves or equatorial waves, which are thought to be far closer to a steady state, but neither are they insignificant, for these short-lived clusters can contain extremely intense

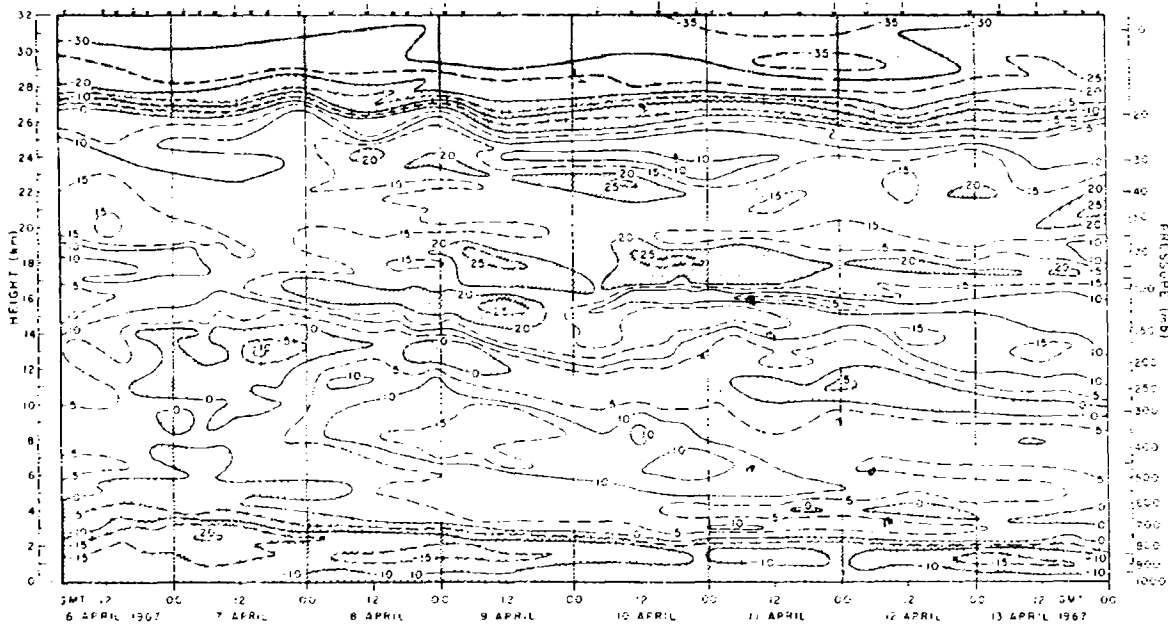
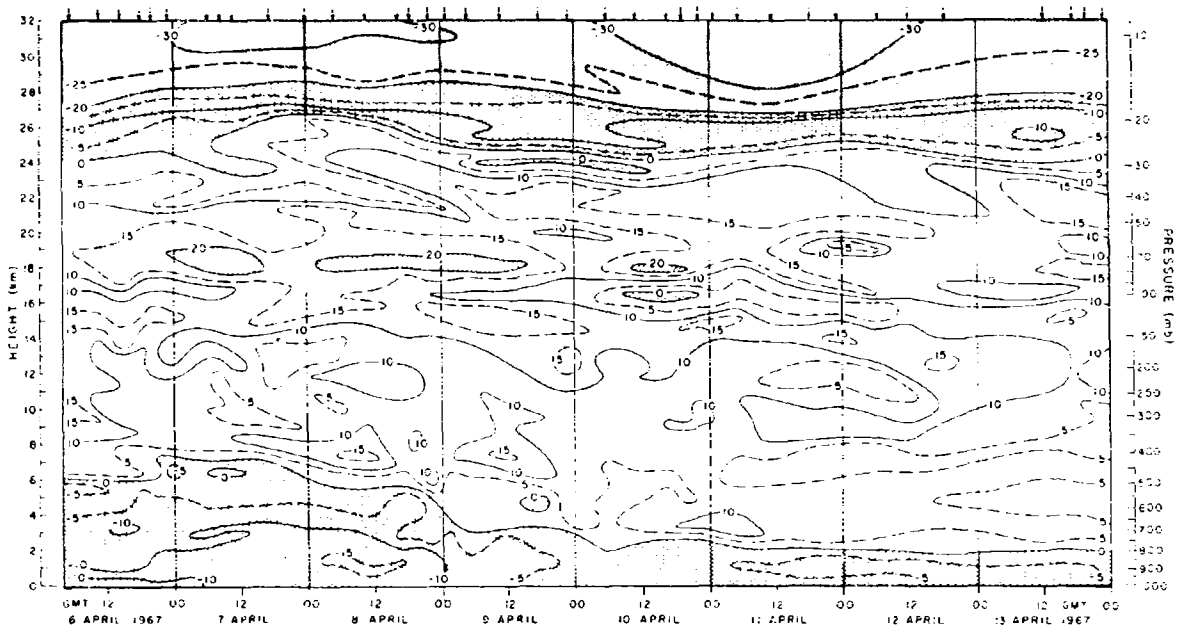

Fig. 1. Height-time cross sections of the u-component, or eastward-directed wind at Palmyra (6N, top) and Christmas (2N, bottom) in meters  $sec^{-1}$ . The time of individual rawinsonde releases is given by the arrows along the top of each section.



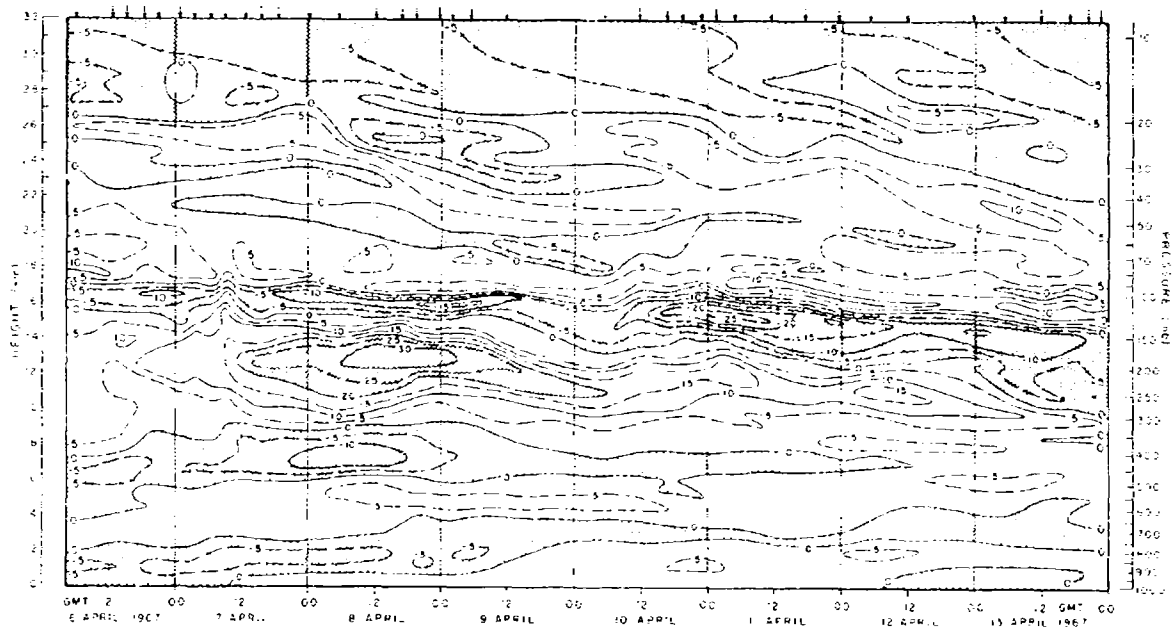
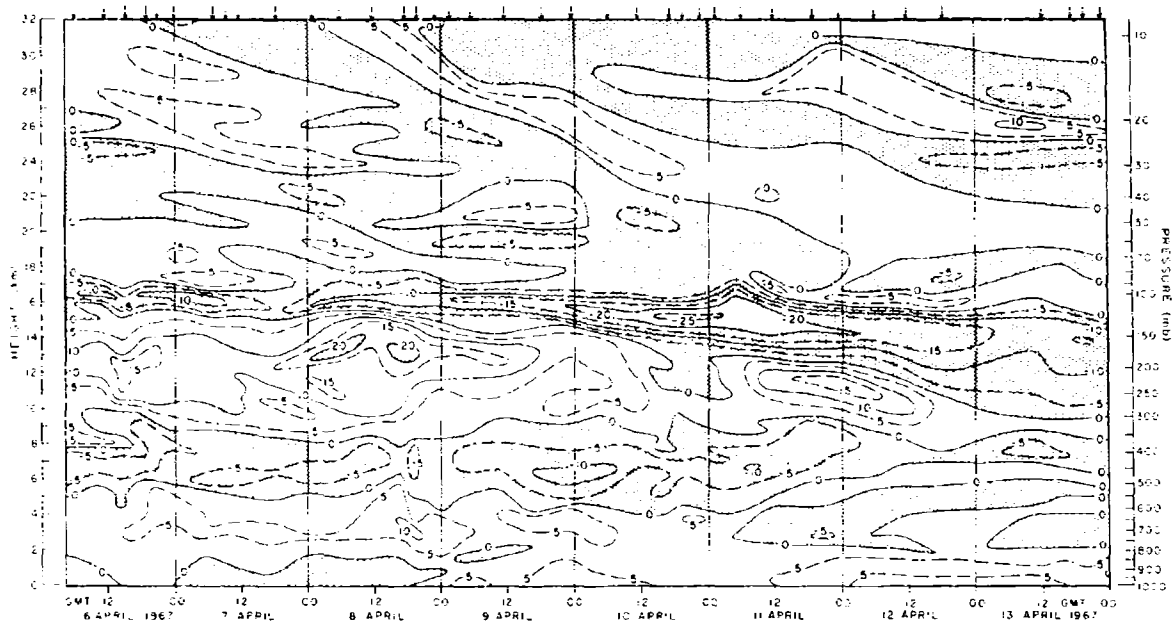
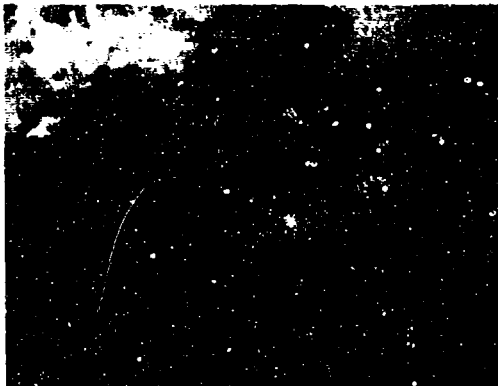

Fig. 2. Height-time cross sections of the v-component, or northward-directed wind at Palmyra (6N, top) and Christmas (2N, bottom) in meters  $\text{sec}^{-1}$ . The time of individual rawinsonde releases is given by the arrows along the top of each section.



(a) ATS-1 picture, 1712 local, 31 March 1967



(d) ATS-1 picture, 1330 local, 1 April 1967

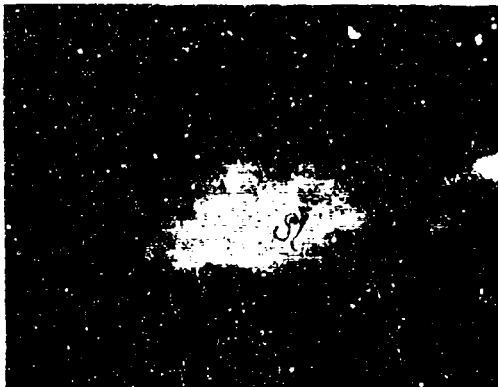

(b) ATS-1 picture, 0920 local, 1 April 1967



(e) ATS-1 picture, 1711 local, 1 April 1967

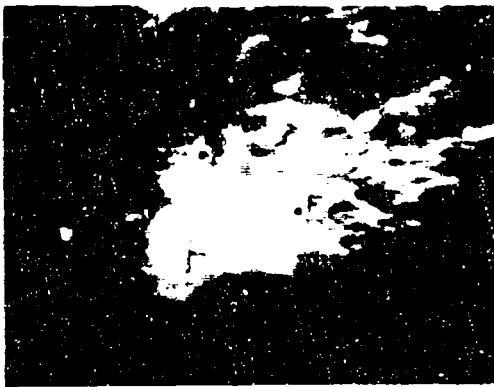

(c) ESSA 4 APT picture, 1005 local, 1 April 1967

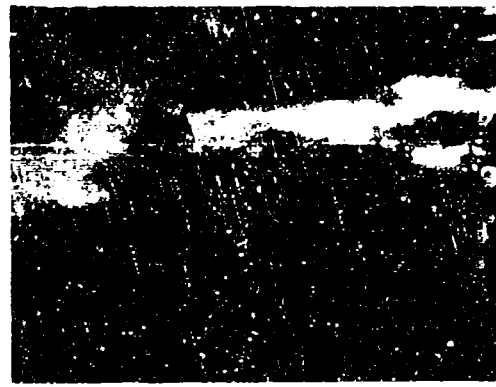

(f) ATS-1 picture, 0819 local, 2 April 1967

Fig. 3. Sequence of satellite pictures spanning the life cycle of the 1 April 1967 disturbance in the Line Islands region. The mesoscale cloud system seen on the previous afternoon (3a, heavy arrow) is probably the only precursor of the disturbance in existence the previous day. The sequence 3b-3e shows the cloud shield of the disturbance dissipating during 1 April, coincident with the rapid expansion of the curved cloud line which marks the leading edge of the downdraft air. Palmyra, Fanning and Christmas Islands are located by letters on each picture.

convection during their short lifetimes and by their great frequency in and near the inter-tropical convergence zone must account for a substantial fraction of the total energy transfers in that zone.

c. The 1968 Barbados Program. This program was primarily a Florida State University program, and it has been described by Garstang and LaSeur (1968). Some of the initial results have been described by Garstang (1969) and I will not have time to discuss them here. I will follow up the previous discussion on the significance of short-lived cloud clusters by showing a few brief case histories of disturbances near Barbados in 1968, the data coming from flights of one of NCAR's fully instrumented Queen Air A-80 aircraft, made in cooperation with the FSU program.

Two disturbances of the short-lived variety passed Barbados, on 18 and 30 August, in which low-level traverses and soundings were made by the research aircraft. In each case, the cloud cluster was at maximum intensity on the day that it passed Barbados and was either weak or non-existent on both preceding and subsequent days (Figs. 5, 6). On both maximum intensity days, flights concurrent with the satellite picture show intense squall lines forming the northern boundary of the cloud system with the vast majority of the system filled with downdraft air in the low levels. In the northern half of the cloud system where the anvils are thick, rain is falling and producing the downdrafts on a scale of some 100 by 200 - 300 km. This was verified by aircraft soundings in these regions, one of which measured relative humidity at 3000 ft in heavy rain of less than 50% by two independent instruments. At 500 ft, the horizontal divergence in these rain areas was the order of  $10^{-4} \text{ sec}^{-1}$ , this in each case under the heaviest satellite-observed cloud cover and on a scale fully an order of magnitude larger than the scale of the active squall line. It becomes easy to understand why each of these cloud systems dissipated quickly.

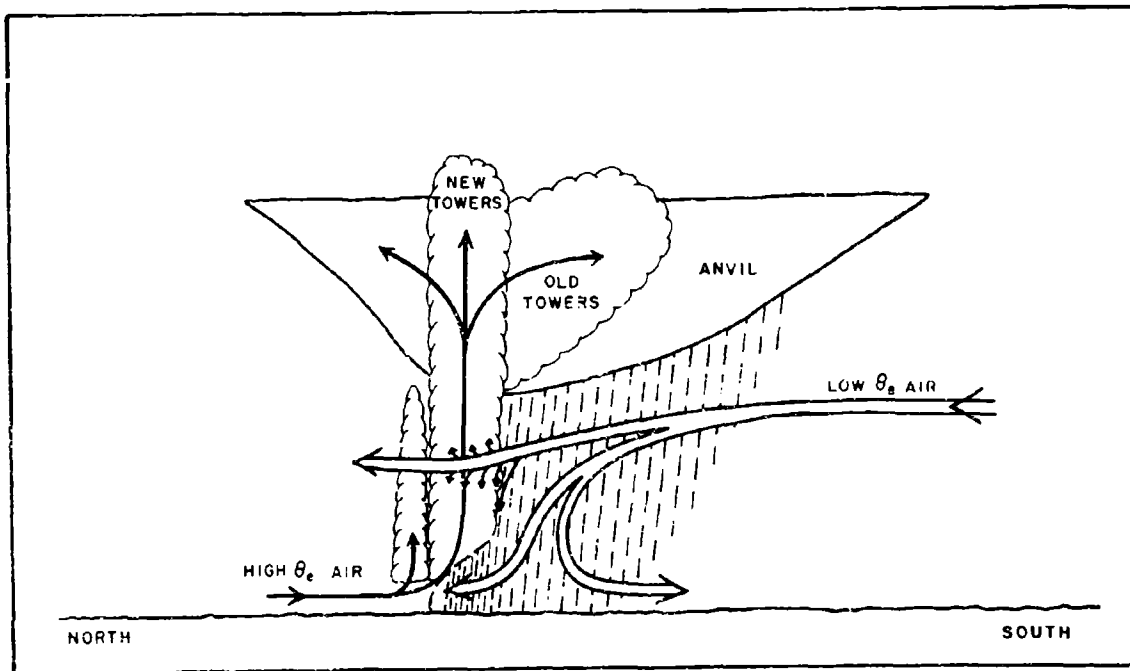

Fig. 4. Schematic streamlines of airflow relative to convective cloud systems in north-south section illustrating the mechanism of downdraft production. The low  $\theta_e$  air in the environment can pass under the anvil without necessarily intercepting convective towers, although such air that does intercept towers can be entrained by turbulent mixing into the towers and can also produce more intense and smaller scale downdrafts than the direct large-scale production under the raining anvil. Compare this diagram with those presented by Newton (1963) for the mid-latitude squall line.

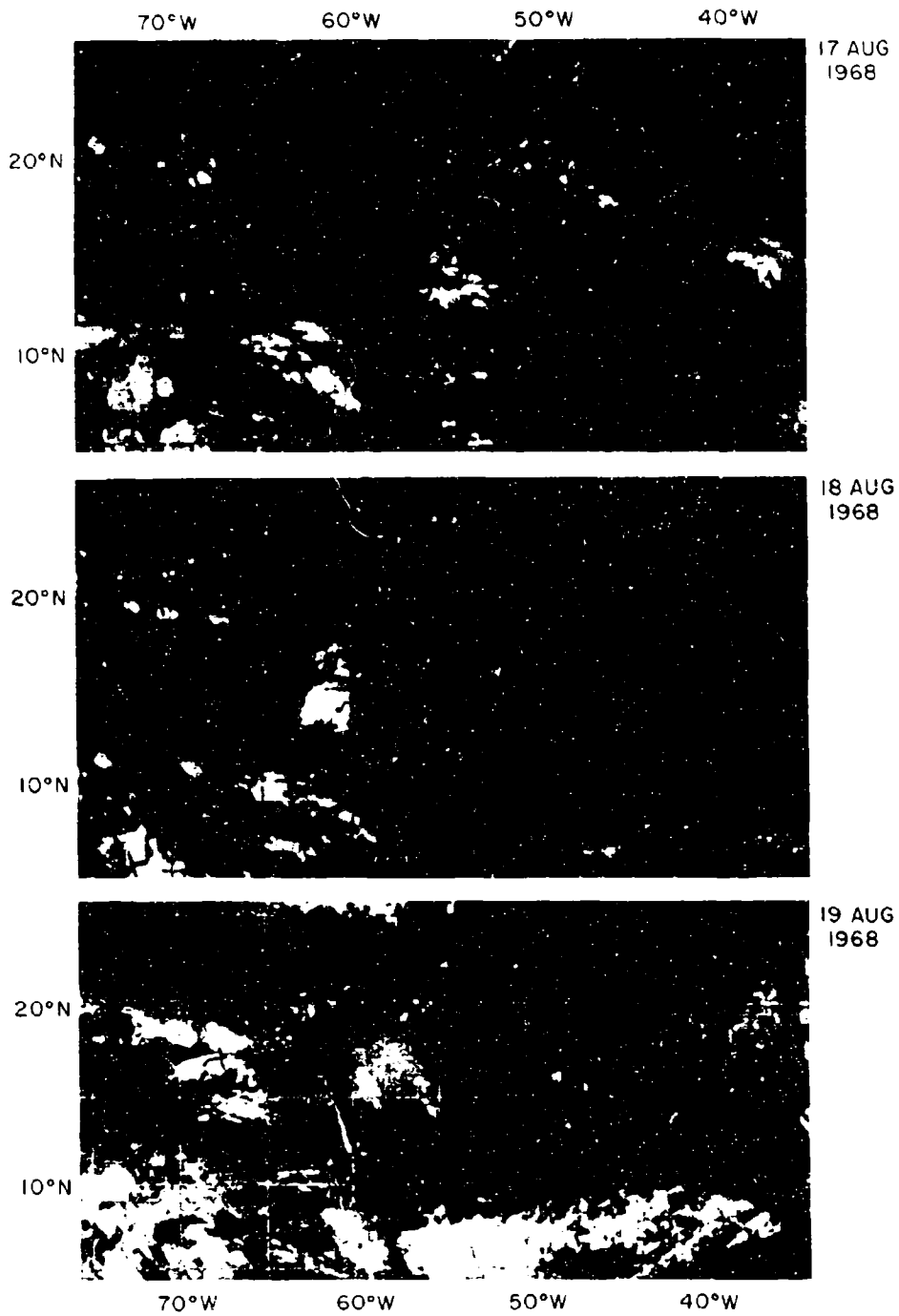

Fig. 5. Digitized mosaics of ESSA-3 satellite pictures of the Barbados region for three consecutive days near 1600 local time. Barbados is located by the black dot at 13.0N 59.5W. The disturbance over Barbados on 18 August had actually completely disappeared by the morning of the 19th; the clouds seen south of Puerto Rico on that picture developed during the day.

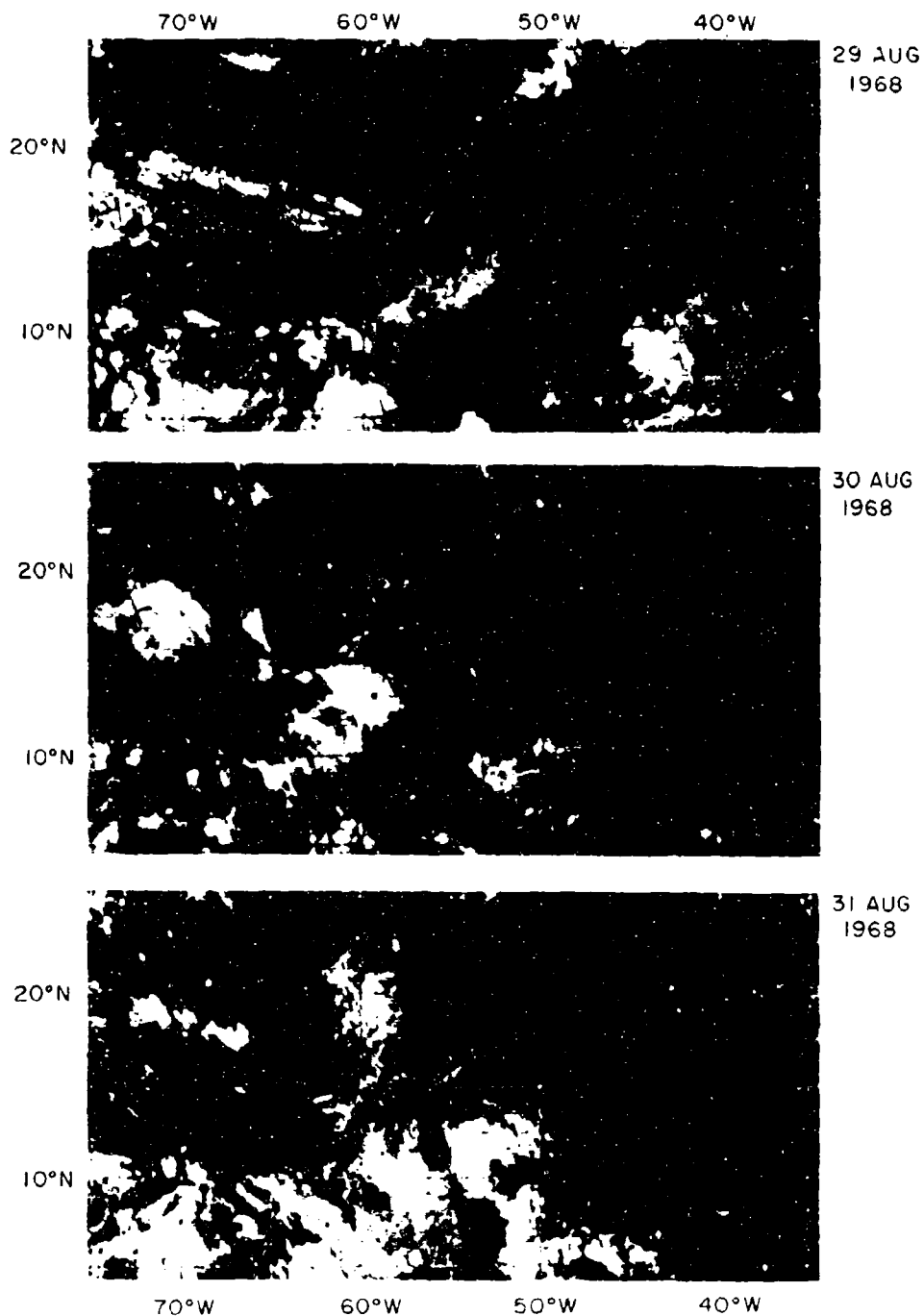

Fig. 6. Same as Fig. 5, but for the 30 August disturbance. The cloud system over Barbados on that day had extended to 65W as a solid intense mass a few hours earlier, but the western part of the system has already dissipated, leaving a very thin cumulus line near 67W. Note the similarity to the case of Fig. 3. At the time of this picture, the research aircraft was crossing the squall line along 15N, the north edge of the disturbance, which was the only intense convection remaining in the system. The pictures on the 29th and 31st are evidence of the system's rapid growth and decay.

A third disturbance was investigated with the same data sources on 1 September (Fig. 7). In sharp contrast with the previous two, it was a well-defined system for several days prior to 1 September and also on the next day, although it was most intense on 1 September. It can be approximated with a relative steady state wave model. On 1 September, had its circulation been about  $3\text{-}5\text{ m sec}^{-1}$  stronger, it could legitimately have been called a minimal tropical cyclone. Significantly, and also in sharp contrast to the previous systems, the 1 September cloud system had only weak downdrafts near its center which were not significantly cooler and drier than the environment, and in fact, substantial portions of the rain area had higher dew-points than the environment. I believe that these differences in downdraft structure are one of the factors to be considered in assessing whether given cloud systems do or do not have the potential to become tropical cyclones.

d. The Barbados Oceanographic and Meteorological Experiment (BOMEX). As you all know, BOMEX is the most ambitious tropical field program to date, and it is still in progress. For an outline of the objectives and the specific program, see Kuettnner and Holland (1969). Despite the large scope of BOMEX, there is no doubt that the basic problems of tropical meteorology, particularly the convective-mesoscale-synoptic scale interaction problem, will not be solved by BOMEX and we must look toward future efforts in the field.

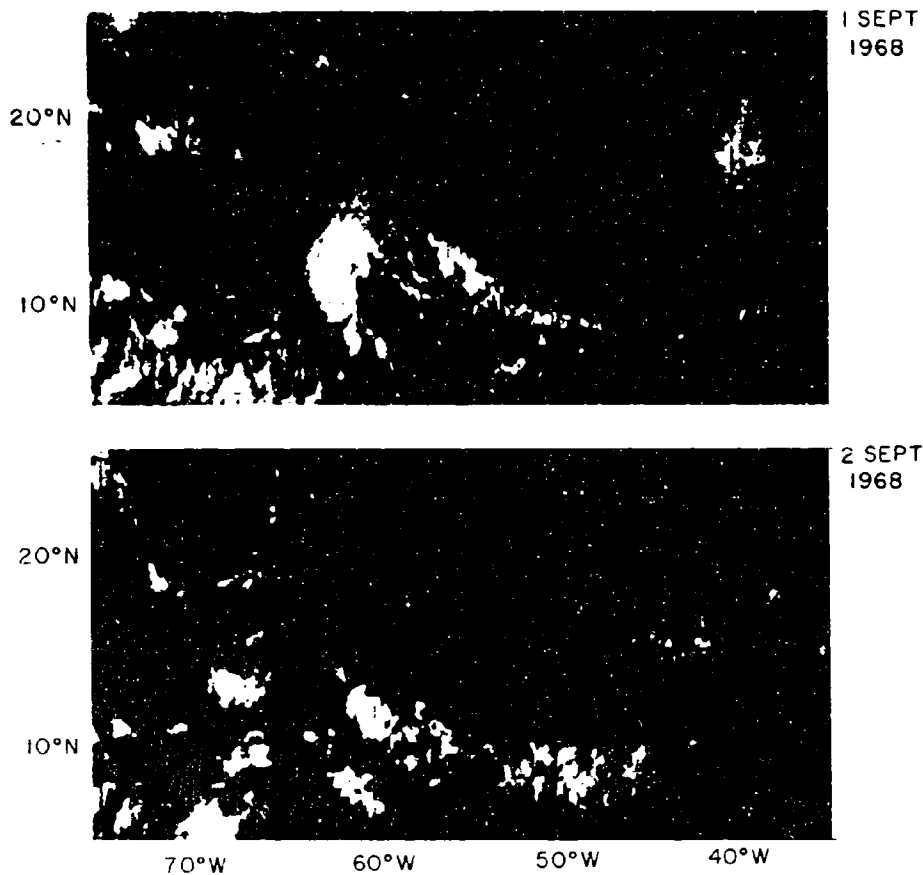

Fig. 7. Same as Fig. 5 and 6 but for the 1 September disturbance. By referring to Fig. 6, this system is easily seen near 43W on 29 August, and although it weakened temporarily the following day, has good continuity through 2 September. Research aircraft data showed this disturbance to have important thermodynamic differences from the two previous ones. See text.

### III. FUTURE PLANS FOR TROPICAL FIELD PROGRAMS

While I will speak about the current status of plans for tropical field programs as part of the Global Atmospheric Research Program (GARP), I should preface these remarks by stating my personal view that it is neither realistic nor desirable to view GARP as having any monopoly on these future programs. There are many, many worthwhile research endeavors in tropical meteorology that can and should be supported independently of the GARP effort. But I also believe that the plans now taking shape as a part of GARP have great significance and deserve exposure at this time, so I will spend the brief time remaining on this subject.

If it can be accepted that one of the most pressing unsolved problems of the tropics is the scale interaction between sea-air transfer, sub-cloud layer turbulence and convection, through the mesoscale and the all-important cloud cluster scale (I prefer to call this the small synoptic scale) and on through the larger scales, it should follow that a field program must be designed which will observe all these scales concurrently, with adequate resolution, areal extent and meaningful accuracy of the meteorological variables.

Similar views have been expressed more eloquently in the most recent planning document on GARP (U.S. Committee for the GARP, 1969). To quote a few pertinent passages:

"Convective cloud clusters represent a special physical problem because...they are not directly driven by surface heat sources. Some of the energy may leak in from middle latitudes or result from shearing instability of the trade wind flow, but after the deep cloud masses are formed the increased condensation heating in the cloud towers must interact with the large scale disturbance fields themselves. When the interaction is sufficiently strong in the positive sense a tropical cyclone...forms. More often, however, for reasons that remain obscure, the net condensation heating is insufficient to do more than produce a weak perturbation in the wind and pressure fields. In these circumstances the cloud cluster exists for two or three days and then collapses (Simpson et al., 1967). Nevertheless, the frequency and intensity of these convective cloud cluster systems is such that they represent the major regions of transformation from latent to sensible heat in the tropical energy balance.\*\* Individually they are major weather producers in the tropics. In the aggregate they maintain the Hadley-cell trade wind circulation and the subtropical jet stream, and to a considerable but uncertain extent they influence the mean and fluctuating atmospheric fields of middle latitudes...." (p. 46)

In the past few years, each of the four or five groups of scientists that have considered this set of problems have assessed their importance (and their difficulty) in much the same terms, and each has recommended an ambitious field effort designed to meet these problems. The most recent recommendations have referred to this program as the Tropical Cloud Cluster Experiment. Quoting again from the U.S. GARP Committee:

"The Committee recommends that the highest scientific priority should go to the cloud cluster experiment [of the six programs recommended]. It is clear that this experiment will be a major undertaking in observational meteorology. The Committee emphasizes that, in order to carry it out successfully four years from now, planning for budgeting and development must begin at once..." (p. 60)

"...[The Tropical Cloud Cluster Experiment] is designed to study the convective and large scale interactions occurring in the wet season cloud cluster disturbance of the central and western equatorial North Pacific and is recommended to be carried out in the summer of 1973.... It is the most important, and certainly the most demanding, of the observational programs proposed in this document. In the cloud cluster disturbances important interactions are believed to occur between radiative processes and boundary layer, cloud scale, meso-scale, and large scale dynamics.... We outline what we believe to be the minimum requirements for a viable cloud cluster experiment. The general structure is similar to that proposed by [four or five other groups], but with the recognition that the larger scale aspects of these proposed experiments cannot be executed until the existence of a more complete global observation system in the middle or late 1970's...." (p. 54-55)

\*\* Italics in original text.

The Committee then goes on to describe the recommended experiment. The Marshall Islands chain is believed to be meteorologically most suitable, and also logistically feasible. The emphasis is on the observation of each scale by the most suitable methods, the inner network of atmospheric sounding systems (a mix of rawinsondes and low-level tethered balloon systems) of 150-200 km spatial resolution in the lowest 2000 m, to be placed within a surrounding network of about 400 km resolution, to be composed of ship and island-based rawinsondes, although the outer ring of this network could be replaced by two jet aircraft if a proven wind-finding dropsonde system can be developed. (Speaking for myself and many others, I can think of no more important development for reconnaissance aircraft of the future than a wind-finding dropsonde of comparable output to the rawinsonde, both for research and operations.) Back to the cloud cluster experiment, there are important roles for weather radar sets, a visual and infrared geosynchronous satellite, and about 10 aircraft, several with highly sophisticated flux measuring capabilities. A final requirement is for a well-equipped analysis and control center, with computer processing of much of the data on a nearly real time basis.

I hope that even this brief description of the status of this one important segment of the tropical part of the GARP has sufficiently highlighted its importance, complexity and also its opportunities. I can think of no challenge more stimulating in all of meteorology than the one of designing and carrying out this program successfully.

#### REFERENCES

- Garstang, M., 1969: Development of experimental systems for, and the study of meso- and convective-scale systems and air-sea interaction in the maritime tropics. Final Report: Phase III, to ESSA under Grant No. WBG-90 and Grant No. E22-148-68 (G). Florida State University, Tallahassee, 103 pp.
- Garstang, M., and N. LaSeur, 1968: The 1968 Barbados Experiment. Bull. Amer. Meteor. Soc., 49, 627-635.
- Kuettner, J., and J. Holland, 1969: The BOMEX Project. Bull. Amer. Meteor. Soc., 50, 394-402.
- Lindzen, R., and T. Matsuno, 1968: On the nature of large scale wave disturbances in the equatorial lower stratosphere. J. Meteor. Soc. Japan, 46, 215-221.
- Newton, C., 1963: Dynamics of severe convective storms. Meteor. Monogr., 5, No. 27, 33-58.
- Simpson, J., M. Garstang, E. Zipser and G. Dean, 1967: A study of a non-deepening tropical disturbance. J. Appl. Meteor., 6, 237-254.
- U.S. Committee for the Global Atmospheric Research Program, 1969: Plan for U.S. Participation in the Global Atmospheric Research Program. National Academy of Sciences, Washington, D. C., 79 pp.
- Zipser, E., 1969: The role of organized unsaturated convective downdrafts in the structure and rapid decay of an equatorial disturbance. J. Appl. Meteor., in press.
- Zipser, E., and R. Taylor, 1968: A catalogue of meteorological data obtained during the Line Islands Experiment, February-April 1967. NCAR TN-35, National Center for Atmospheric Research, Boulder, Colo., 362 pp.



## SYNOPTIC ANALYSIS MODELS FOR THE TROPICS

R. H. Simpson

National Hurricane Center, Miami, Florida

Analysis models for the tropical Atlantic used operationally at the National Hurricane Center, Miami, are defined, and the experience in applying these models with the help of the meteorological satellite is discussed. Hurricane seedlings--rain disturbances from which severe tropical cyclones may grow--occur in large numbers and from many sources. However, only about 10% ever acquire gale or hurricane force winds. Of those which do, one in five develop in temperate latitudes from an initially baroclinic environment.

Machine analyses and prediction of disturbances in the tropics are presently impracticable, first because of the difficulty in filtering the transitory features of circulation while retaining the conservative properties; and second because vorticity expresses itself mainly through horizontal wind shear which is difficult to describe. The first problem may be alleviated by the use of deep layer mean circulation analyses. The second may be partially corrected by empirical use of cloud band configurations viewed by satellite.

The dynamical prediction of hurricane development may have to await the evolution of an asymmetric hurricane model. However, an improvement in hurricane movement predictions may soon be possible by applying barotropic prediction models to the vertically averaged circulation of a tropospheric layer whose depth is proportional to the central pressure of the hurricane.

### I. Introduction

If the meteorological satellite has opened new doors of opportunity for tracking disturbances, it has also confronted the tropical meteorologist with a hierarchy of new weather interpretation problems. This has led to a re-examination of synoptic analysis models as to validity and efficaciousness.

The National Hurricane Center (NHC) at Miami, Florida, through one of its supporting branches the WMO Regional Center for Tropical Meteorology (RCTM) has been conducting such a re-examination during the last three years, with the result that some analysis models have been redefined to enhance their operational usefulness. This paper is concerned with these models and with the implications of experience in applying them.

In view of the fact that many papers presented at this Conference have been concerned with various applications of computer technology, I should explain at the outset that the models discussed here refer to those used in *hand* analyses at Miami. For reasons which we shall soon discuss, our understanding of tropical disturbances and their growth has not yet reached the point that machine analyses can be devised to deal effectively with these systems. This is not to say that very adequate machine analyses and prediction models cannot be applied in the tropics if one is willing to ignore the numerous, persistent, and generally benign synoptic scale rain disturbances. To do so, however, is to ignore the most important product of tropical weather, the hurricane and its antecedent conditions.

For this reason the role of the computer at Miami is mainly for diagnostic and for data handling purposes, except for the objective predictions of hurricane movement.

### II. Redefinition of Models

A synoptic analysis model generally strives to relate a unique circulation property or system

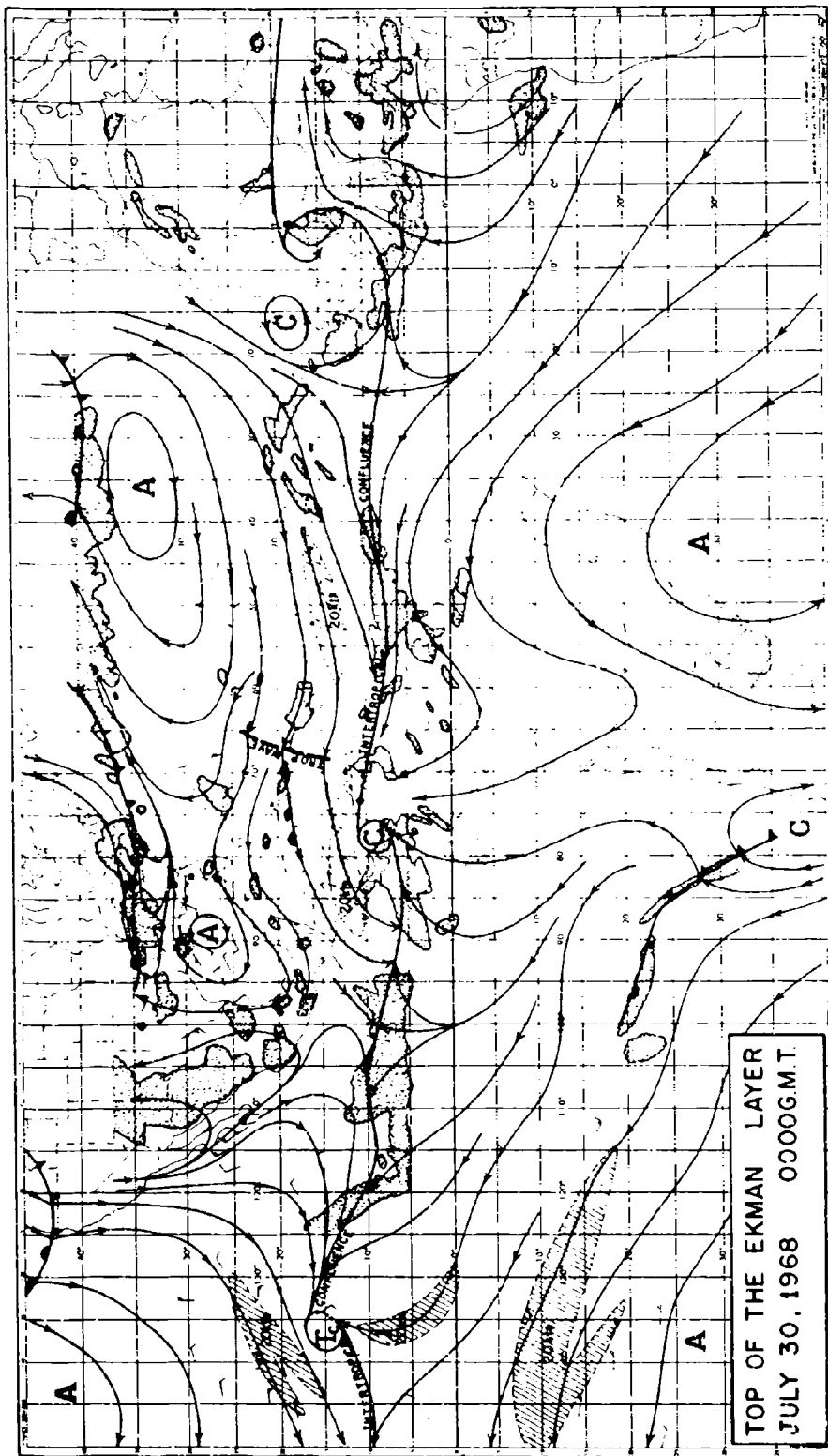

Figure 1. Streamline analysis of the "Top of the Ekman layer" (TOE) charts. This analysis is based upon wind's 3000 feet above the surface. Ship winds at deck level are superimposed to assist in the directional analysis. Stippled areas represent the cloudiness viewed by satellite.

to a characteristic pattern of weather with which it tends to be associated by virtue of the circulation dynamics. Synoptic models in the tropics have not always attempted to describe circulation dynamics except by inference, and in some instances have alluded only to cloudiness patterns without reference to circulation properties. The redefinition of models now in use at NHC does not entirely alleviate these deficiencies, but does attempt to encourage the analyst to look a bit deeper into circulation properties, including the interaction between several scales of motion, to explain the migratory weather patterns he observes (Simpson et al, 1968).

The five models presently identified in analyses at Miami are defined as follows:

- a. Intertropical Confluence (ITC). A nearly continuous "fluence line" representing the principal asymptote of flow in the equatorial trough.
- b. Shear line. A line of maximum horizontal shear frequently associated with the remnant deformation of old frontal zones which have reached a barotropic environment.
- c. Tropical Wave (TW). A trough or cyclonic curvature maximum in the trade wind easterlies.
- d. Tropical Disturbance (Td). A discrete rain system generally 100-300 miles in diameter of non-frontal, migratory character.
- e. Tropical Depression (Tc). A Td with closed circulation in the lower troposphere, maximum (sustained) winds less than 34 knots.

Here the ITC is defined as a circulation entity rather than a zone of weather. Experience shows that the so-called inter-tropical convergence zone involves cloudiness which may be associated with wind speed convergence, with confluent flow, with cyclonic eddies, or a combination of these. It seems more appropriate for purposes of analysis to define a circulation entity which has time continuity regardless of the continuous or discontinuous character of the associated cloudiness, rather than to identify the ITCZ cloudiness by a pair of "railroad track" lines of varying width which do not relate even implicitly to circulation properties. Figure 1 shows an example of the ITC as defined here, based upon a streamline analysis of the 3000 ft. level.\*

The shear line is a more common source of tropical cyclogenesis than is usually acknowledged, and more will be said of this later.

The term tropical wave is used as a more general classification of trade-wind wave disturbances than that of easterly wave. It includes not only the barotropic easterly wave which we now believe may be unique to the Atlantic Ocean but also the upper-level cold low which is reflected at the surface, the trough in the trade winds imposed by an ITC disturbance, and the trough which stems initially from a discrete disturbance on a shear line.

Approximately half the tropical waves identified in the RCTM analyses during the last two years were first detected over eastern Africa. As they progressed westward across Dakar into the Atlantic with some reaching the Lesser Antilles, time cross sections have shown these to have the structure of the barotropic easterly waves described by Riehl (1945). Figure 2\*\* shows a series of such waves over the African continent. The evidence still accumulating, but as yet inconclusive, suggests that the barotropic easterly wave may indeed have a unique source in the semi-permanent trough west of the Abyssinian Plateau.

The cloudiness associated with tropical waves from African sources (see Frank, 1969) is often widespread and usually includes a system of convective cloud bands aligned in a

---

\* This TOE chart (Top of Ekman Layer) is nominally an analysis of flow 3000 feet above the surface in which shipboard wind directions are assumed to be conserved with height.

\*\*Analyses courtesy of Dr. Toby Carlson, NHRL, Miami

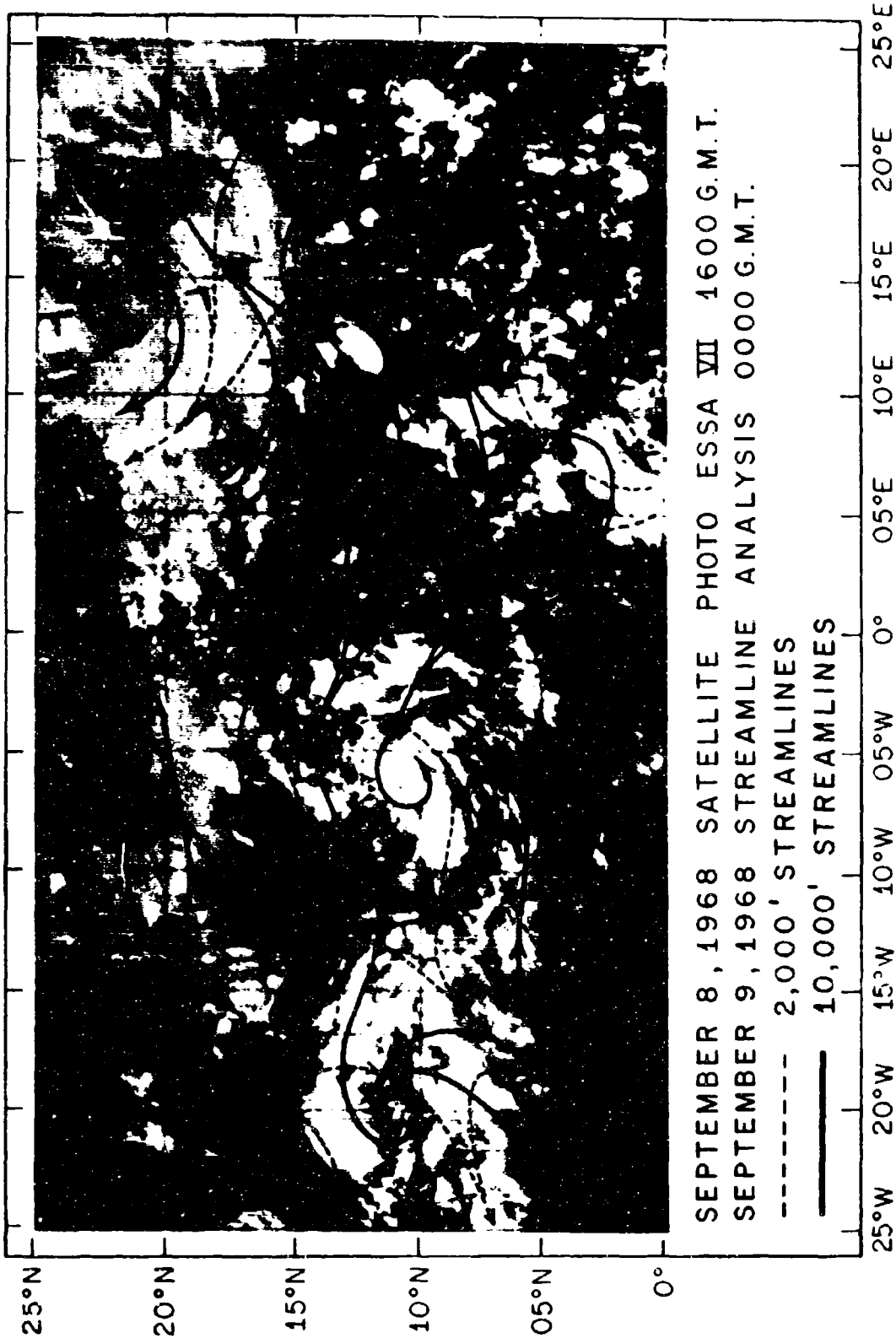

Figure 2. A succession of tropical disturbances in the easterly flow over Africa.



Figure 3. An "inverted V" wave disturbance in the Central Atlantic imbedded in the trade winds north of an active ITC. The latitude and longitude squares are for intervals of 5 degrees. The amplitude of the wave disturbance as regards circulation in the lower troposphere is not self evident from the orientation of cloud lines in this system.

pattern resembling an inverted "V". Figure 3 shows the cloud patterns viewed by satellite in connection with an inverted "V" wave disturbance.

Many synoptic scale migratory rain systems viewed by satellite move into areas of abundant surface and upper-air observations without reflecting their presence in the dynamics of circulation in the synoptic scale. In at least one instance (J. Simpson et al, 1967), synoptic analyses of such a disturbance were supported by sub-synoptic scale data from a research aircraft with no evidence of vorticity or divergence patterns emerging to support the organized convection in the system. Apparently such systems are sustained by a subtle interaction between the synoptic and convective scales of motion. Nevertheless, they are important entities to tropical cyclogenesis because of the large continual releases of latent heat over discrete areas. Therefore, they are identified and tracked from day to day by satellite and identified as  $T_2$ 's. The tropical disturbances, as defined, is the basic generic form which in successive stages of development may become a tropical wave (TW), a tropical depression ( $T_1$ ), and ultimately a tropical storm or hurricane.

### III. Hurricane Seedlings

While the immediate objective of tropical analysis models is to permit systematic identification and tracking of weather producing systems, the ultimate goal is to keep tabs on those disturbances which may produce severe storms and hurricanes, and to aid in understanding and predicting these developments. Before discussing the hurricane seedlings in the traditional trade-wind environment, it should be pointed out that at least 20% of the named tropical cyclones in the Atlantic develop from disturbances which originate in temperate latitudes. Indeed the majority of these are bred in an initially baroclinic environment. Initial accelerations and surface pressure falls probably stem mainly from baroclinic instabilities. Figure 4 shows a typical development of this kind in which circulation acceleration begins in a frontal wave disturbance. This is followed by rapid rises in geopotential in the middle troposphere and the disappearance of frontal properties. Low-level forcing action then entrains mass into the residual low-pressure center. Finally, with establishment of mass circulation organized convection releases latent heat in patterns which account for further pressure falls.

In the five-year period 1964-1968, 8 tropical cyclones developed in this manner, 5 of which acquired full hurricane force.

Hurricane seedlings in the tropics frequently have a long over water history before finding an environment favorable for intensification as stated earlier. Many of these originate over Africa. Since the tropics are filled with migratory rain systems, most of which are transitory in character, it becomes a daily task of the analyst to try to "separate wheat from chaff". This cannot yet be done objectively. However, experience does provide a few dependable guidelines. First, intensification does not occur in a disturbance which originates on the ITC until it breaks out and becomes completely embedded in the trade winds. Secondly, it is the small intense convective systems usually quite separate from other large cloud entities, which offer the greatest threat for rapid intensification. Large sprawling convective systems generally remain benign.

For the past two years a careful census has been kept of disturbances in the Atlantic hurricane belt. Figure 5 shows schematically the regional origins of these seedlings, and Table 1 shows the comparison of disturbances in 1967 with those of 1968. Since only about 1 in 10 seedlings succeed in developing gale or hurricane force winds, it becomes more of a challenge to identify the constraints to hurricane formation than to specify the environment which may permit development.

### IV. Identifying the Conservative Circulation Patterns

When one views a movie of daily cloud patterns in the tropics seen from the satellite, it becomes immediately apparent that a large portion of the cloudiness is of low persistence, apparently associated with transitory systems.

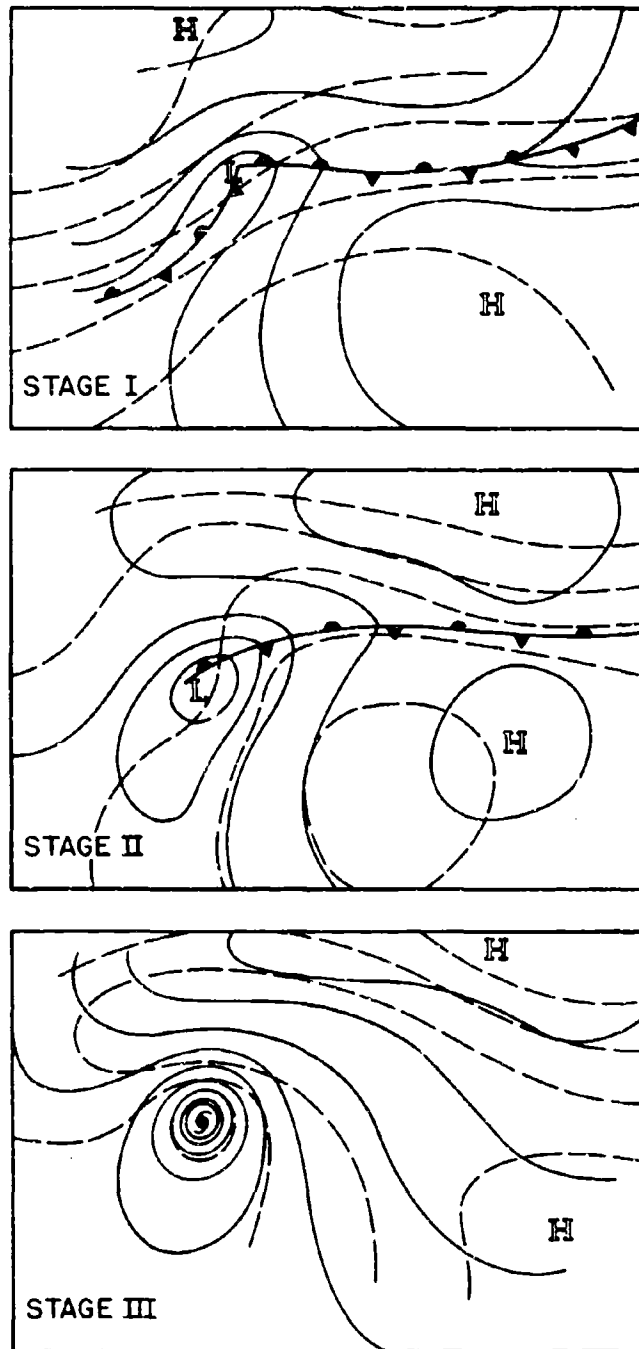

Figure 4. Development of a hurricane from an initially baroclinic environment. Approximately one out of five hurricanes have their origin in a frontal wave or shear line in which initial pressure falls probably come from baroclinic accelerations. As the convection becomes organized subsequent pressure falls are due to the release of latent heat.

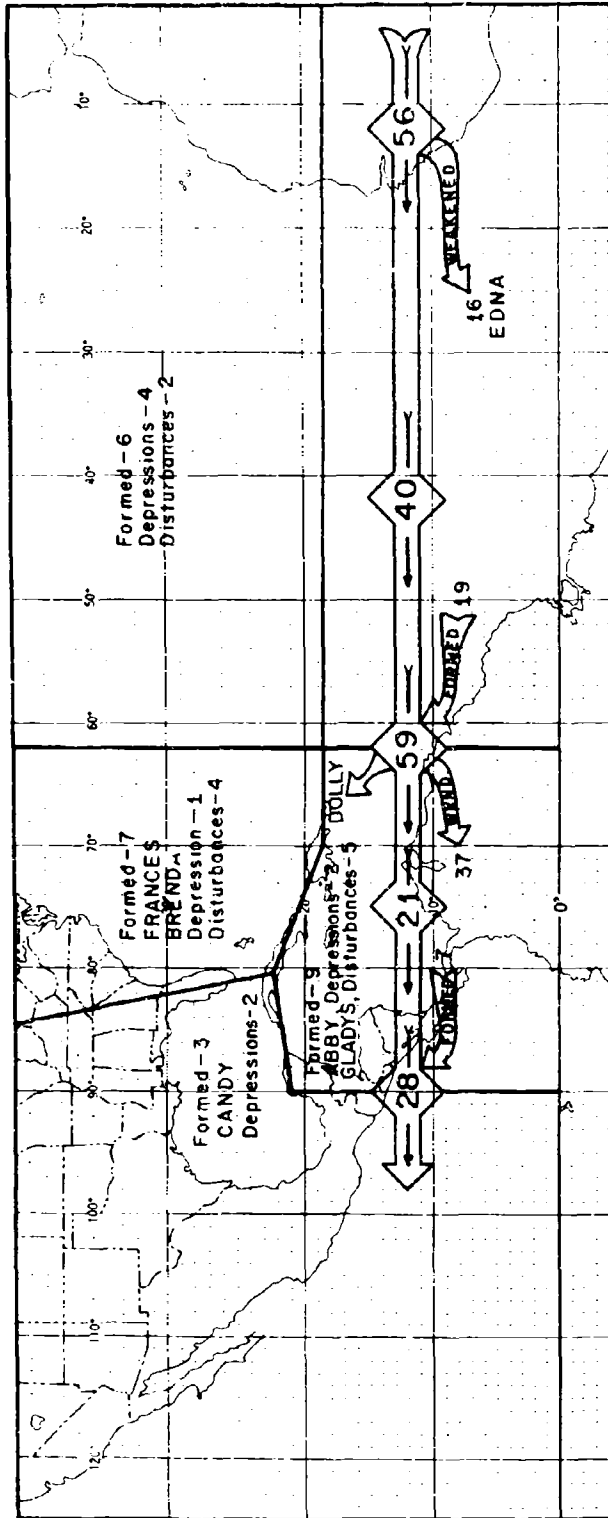

Figure 5. Sources of tropical disturbances in the Atlantic and the migration of these disturbances during 1968.



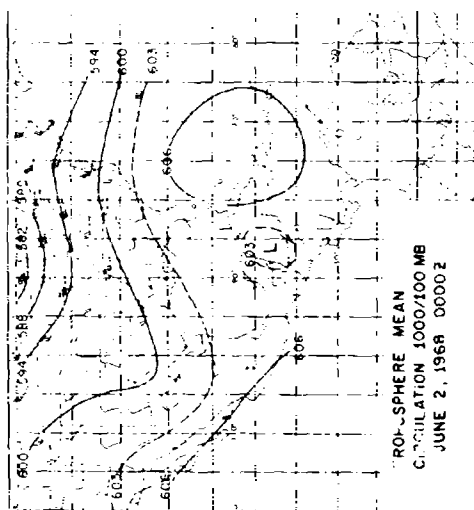
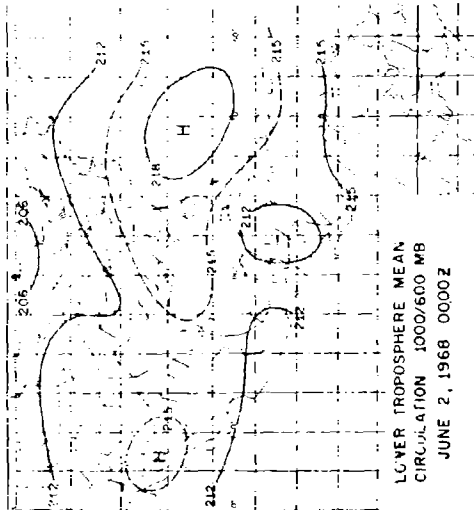
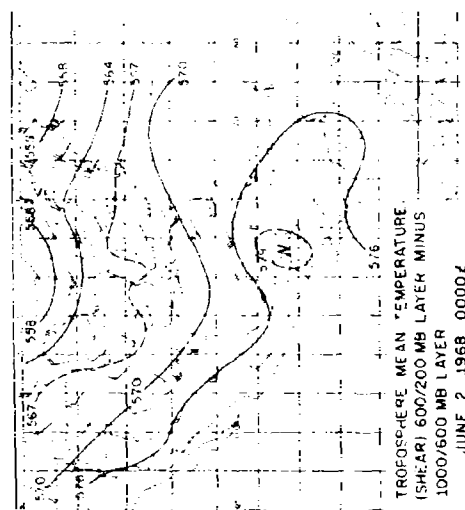
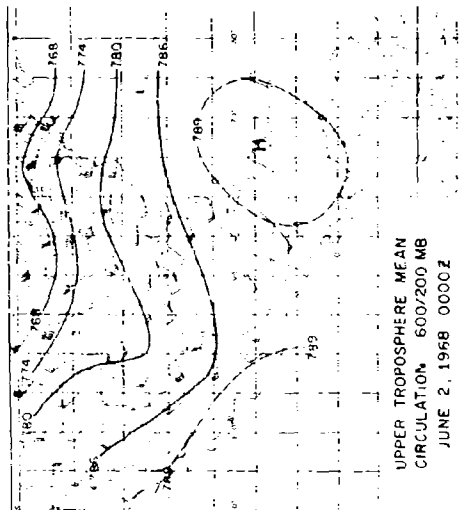

Figure 6. Examples of troposphere mean circulation and temperature analysis for the tropical Atlantic and Caribbean.

Such a technique will be tested operationally this summer. This will draw upon deep layer mean circulation analyses, smoothed horizontally to remove hurricane size eddies. Changes in this smoothed flow will be predicted barotropically, and the point vortex moved with the changing flow. Depth of the mean layer will vary with the central pressure of the hurricane. Preliminary tests have given good results. The strength of this method is expected to be in the predicted direction of movement rather than speed of movement.

#### VII. Outlook for the 1970's

With the advent of new data collection systems including SIRS and IRIS satellites, machine analyses of the tropical circulations will probably become adequate to describe the input of the tropics to temperate latitudes, and for such purposes as may be required by Aviation for enroute wind and temperature data. However, none of the systems which are now "in the wings" for use in the 1970's is likely to describe the interaction between convective and synoptic scales of motion sufficiently well to permit reasonable numerical predictions of the movement and development of disturbances.

The greatest hope lies in the diagnostic use of the conventional satellite to parameterize the distribution of vorticity from the configurations of convective cloud lines and clusters, and the judicious use of geocentric satellites to obtain both low and high-level wind velocities from measured cloud movements.

The use of mean layer circulations as a basis for prediction may lead to considerable improvement in prediction of hurricane movement, if not the survival and development of hurricane seedlings.

TABLE 1

Monthly Comparisons of Atlantic Tropical Systems in 1967 and 1968

	<u>DEPRESSIONS</u>		<u>DAKAR WAVES</u>		
	<u>1967</u>	<u>1968</u>	<u>1967</u>	<u>1968</u>	
Jan-May	--	2	--	--	
June	4	4	6	7	(1)
July	2	2	8	15	(1)
Aug	7	3	7	16	(4)
Sept	6	7	6	11	(1)
Oct	10	2	3	8	(3)
Nov-Dec	$\frac{0}{29}$	$\frac{2}{22}$	$\frac{--}{30}$	$\frac{--}{57}$	(10)

( ): ITC disturbances which passed south of Dakar and would not have been considered in 1967.

Table 1. A comparison of the tropical disturbance censuses for 1968 and 1967.

This transitory character reflects itself in the analysis of tropical circulations where, in weak fields of motion, circulation anomalies percentagewise may be large, and the analyst must find a means of separating the transitory from the conservative perturbations. This is one reason why it is difficult to make machine analyses of tropical circulations which properly identify and describe disturbances. And, of course, this difficulty limits the effectiveness of prediction models.

In seeking some effective means of filtering the transitory patterns and retaining the conservative features of circulation, the NHC has for the past two years placed emphasis on the analysis of deep layer mean charts which, experience shows, comes close to accomplishing this objective (see P. Simpson, 1969, Regional Technical Memo. 47). The three fundamental charts used are the 1000-600 mb and 600-200 mb layers and the troposphere mean shear chart consisting of the subtraction of the two mean layer analyses. An example of these is shown in Figure 6. These circulation charts have consistently revealed the conservative features of circulation, and generally have shed those transitory features many of which are prominent at only one level of analysis. The thermal wind chart has been useful in identifying the areas of minimum vertical wind shear, a condition which is necessary for development of hurricanes (Gray, 1968). For the present we consider that these charts comprise an optimal description of flow patterns for diagnostic if not for prediction purposes.

#### V. Predicting Development

To describe a field of streamlines is one thing and can generally be accomplished with good approximation in the tropics. To describe the distribution of vorticity or divergence is quite another thing. In the tropics this is especially difficult because vorticity, except in tropical cyclones, is almost entirely expressed through horizontal wind shear, while divergence often depends as much upon gradients of wind speed as upon diffluence. Moreover, as noted earlier many synoptic scale migratory disturbances seem to be sustained by vorticity patterns which may result from the interaction of convective and synoptic scales of motion.

Yet, the success of a prediction model depends upon an adequate initial description of the field of vorticity or divergence. Obviously, what may be adequate for large scale circulation patterns are patently inadequate in the tropics for disturbances of the size we have discussed here.

There is little hope to obtain observations at close enough intervals to describe such motions explicitly. However, there is a possibility of relating certain convective cloud clusters and configurations viewed by satellite to the vorticity distributions in the immediate environment. Spiraling curved cloud bands frequently appear in a field of nearly straight flow. Quite possibly these may provide a means of parameterizing the horizontal wind shear and thus the vorticity of the environment. Ultimately such indirect constraints to analysis as this may provide an adequate basis for prediction. An experiment with this in mind will be attempted at NHC during the coming year.

#### VI. Predicting Hurricane Movement

The effective prediction of hurricane development may have to await the development of an asymmetric hurricane model. However, the prediction of hurricane movement may get a boost soon if preliminary tests are indicative.

First, it must be conceded that the statistical screening methods which have been the principle objective aid in hurricane forecasting, probably have run their full course of usefulness. The problem is that there are now so many predictors involved that the hurricane forecaster cannot logically rationalize the errors from this method. Therefore, when the hurricane is predicted to move eastward on the basis of data at 0000 GMT, then westward on the succeeding data at 1200 GMT, the forecaster must content himself with frustration, and usually with a decision which is guided mainly by persistence and climatology. What is urgently needed is a technique which will dependably predict the conservative features of circulation by dynamical means, whose errors have some continuity in time.

#### REFERENCES

- Frank, Neil, 1969. The "Inverted-V" Cloud Pattern--An Easterly Wave. Monthly Weather Review, 97:2
- Gray, Wm. M., 1968. Global View of the Origin of Tropical Disturbances and Storms. Monthly Weather Review, 96:10
- Riehl, H., 1945. University of Chicago Miscellaneous Report No. 17
- Simpson, J., M. Garstang, E. Zipser, and G. Dean, 1967. Journal of Applied Meteorology, 6:2
- Simpson, R. H., 1969. Disturbances in the Tropical and Equatorial Atlantic. Regional Technical Memo, 47 (USWB)
- Simpson, R. H., Neil Frank, D. Shideler, and M. Johnson, 1968. Atlantic Tropical Disturbances of 1968. Monthly Weather Review, 97:3, pp 240-255
- ...., 1967. Atlantic Tropical Disturbances. Monthly Weather Review, 96:4

## THE USE OF SATELLITE DATA IN THE TROPICS

Ralph K. Anderson  
and

Vincent J. Oliver  
National Environmental Satellite Center

For several years, polar-orbiting satellites have given us a daily view of the clouds over the entire area of the tropics. From these pictures, we have learned how to interpret the clouds in terms of upper and lower tropospheric flow, to identify tropical storms and to estimate their intensity. This knowledge is now being applied to daily synoptic analysis. These data, by means of different forms of processing, have given us new information on:

1. The cloud climatology of the tropics;
2. The day-to-day motion of systems in the tropics;
3. The formation and extent of the ITCZ cloudiness;
4. The formation and development of tropical storms, and
5. The existence and position of high level wind maxima which carry moisture and energy from the tropics to higher latitudes.

New data are now becoming available for operational use. These include movies from ATS-I, temperature soundings from SIRS on Nimbus III and HRIR data from Nimbus III.

This paper presents our latest findings from the satellites and illustrates them with selected movies showing the weather in motion. Satellites of the near future and their application possibilities are discussed. These include the use of moisture sensors from Nimbus, atmospheric soundings from satellites, and the IR telescope data.

### I. Introduction

With the advent of satellite observations nearly a decade ago, tropical meteorology entered a new era. The ability to observe tropical cloud systems globally, and on a daily basis, has greatly increased our understanding of the circulations in the tropical atmosphere. Satellite observations have settled many arguments. For example, we now have a much better knowledge concerning the nature and extent of cloudiness along the ITCZ. But at the same time, these data also reveal many new phenomena that await explanation.

Today, satellite observations are being used in almost all areas of tropical meteorology, both applied and research. The operational meteorologist has come to rely heavily on daily satellite data as a diagnostic tool for analysis and forecasting. The research meteorologist has access to an abundant amount of data from a wide variety of sensors with which to attack problem areas. This paper briefly summarizes where we presently stand in our application of satellite data to tropical meteorology, and what we may expect in the next five years.

### II. The Use of Data in Daily Synoptic Analysis

Synoptic meteorologists dealing with the tropics use the daily ESSA pictures to locate many features of the tropical circulation. These include tropical cyclones, the ITC, low level shear lines, lower tropospheric wave disturbances, the subtropical jet, upper tropospheric vortices and the upper tropospheric mid-oceanic troughs. All of these can be identified and tracked from day-to-day (1). To do this, various aspects of the clouds are examined.

Cloud organization and the distribution of cloud type and amount are used to infer the flow pattern for both the lower and upper troposphere. For example, the upper tropospheric mid-oceanic troughs, a common feature of the large-scale circulation over both the North Atlantic and the North Pacific during the summer, produce a recognizable cloud distribution. Portions

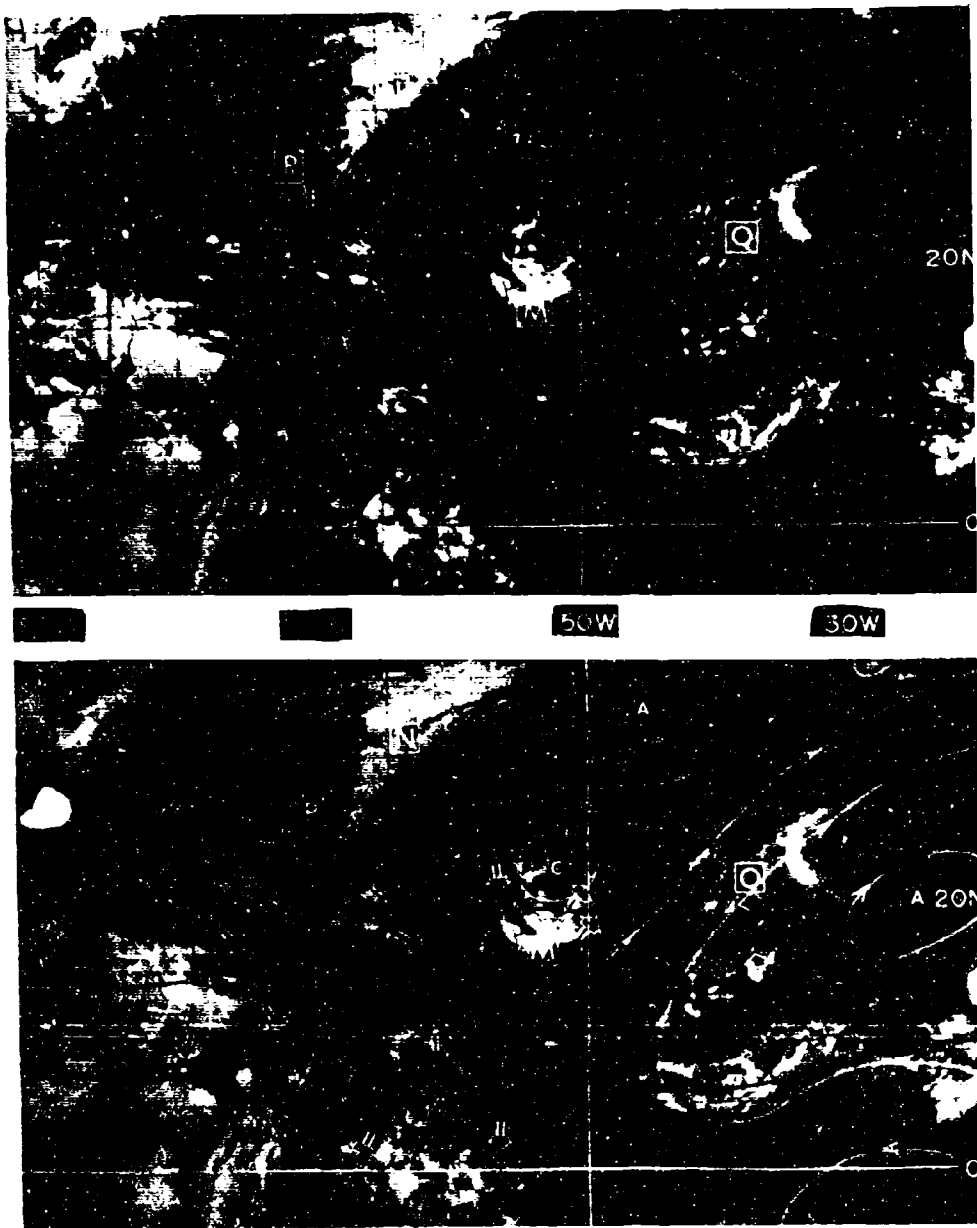

Figure 1. Mid-Pacific trough, 0000 GMT, September 7, 1969. A computer montage of the satellite data for a portion of the North Pacific Ocean is shown at the top. The same satellite picture appears at the bottom with the surface pressure analysis (black) and the 250 millibar streamline analysis superimposed. Black arrows represent surface wind direction. The area of minimum cloudiness southwest of P is located in the upper level trough while P and Q are cloud formations associated with vortices along the trough. Cirrus clouds extend northeast from the cloud mass at R in the southwesterly upper level flow east of the trough. Cirrus plumes at S indicate northeasterly flow west of the trough. The vortical cloud pattern near T is associated with a weakening tropical storm.

of the trough axis are associated with a cloud minimum. Long streamers of cirrus cloud are often present in the southwesterly flow to the east of the trough line. When the trough is in the form of an upper level shear line, the shear line lies immediately northwest of the edge of this cirrus. Upper level vortices are often present along the trough. These have identifiable cloud systems which, besides locating the vortex, help to define the trough axis. Figure 1 shows an example of the clouds associated with a mid-oceanic trough.

Cirrus formations are used to estimate upper tropospheric wind vectors. In the tropics, cirrus plumes from thunderstorms, and the cirrus formations along subtropical jets, can be interpreted in terms of representative 200 millibar winds<sup>(2)</sup>. For the past two years, the National Environmental Satellite Center has provided such wind estimates on an operational basis to the National Meteorological Center.

Pictures are examined in the light of new models which describe the evolution of the cloud formations and patterns which accompany synoptic-scale disturbances. These models are based primarily on satellite data. Frank<sup>(3)</sup> has described the inverted 'V' tropical wave formations that occur in the Atlantic; Sadler<sup>(4)</sup> has modeled the cloud formations produced by upper tropospheric cold core lows in the central and eastern Pacific, while Fett<sup>(5)</sup> and Fujita<sup>(6)</sup> have proposed models which describe the evolution of disturbances along the ITCZ. Although these models must be considered preliminary because of the limited number of cases on which they are based, they do provide considerable assistance when applied to daily analysis.

A classification system for tropical storms based on cloud system appearance and size is also in use<sup>(7)</sup>. This system provides information regarding the intensity and stage of development of tropical storms and also yields an estimate of the storm's maximum surface wind. The system has proven quite successful in diagnosing the intensity of tropical cyclones in the absence of other reports.

### III. Interaction Between Low and High Latitudes

Satellite data are supplying research meteorologists with new insights with regard to the interaction between low and high latitudes. Of particular interest are the bands of cirrus (figure 2) which are associated with high level wind maxima. These play an important role in the export of moisture and energy from the tropics. Studies show that the cirrus clouds are associated with these maxima. In the Northern Hemisphere, the cirrus first forms over or just to the north of the equatorial cloud band. In both hemispheres, the region of stronger upper level current is detectable poleward from the point where it picks up moisture from tropical convection. Measurement of cirrus motions show that the air is accelerating and turning anticyclonically as it moves poleward. Figure 3 shows the geographical distribution of these bands during the year ending May 1969. In each hemisphere, the bands occur most often during the winter season. The asymmetry revealed here is an important characteristic of the general circulation which must be adequately explained.

### IV. Cloud Climatology from Digitized Data

When satellite imagery is averaged with time, a form of cloud climatology results. A series of averages for the tropics have recently been compiled from 1967 data<sup>(8)</sup>. Thirty-day and 90-day averages were produced. The averaging was done photographically using the mapped digital data from ESSA-3 and 5. The result is an average brightness map for mid-afternoon local time from 40°N to 30°S.

The 30-day average over Southeast Asia for January 1967 is shown in figure 4. This treatment of the data shows how terrain effects and local circulations affect the mean cloud distribution. Note the minimum of clouds west of the northern Philippines (A) and the maximum of clouds in southern China (B). Both of these effects result from mountain barriers in the northeasterly low level flow. In Indonesia, the effects of differential heating and sea breeze circulations concentrate the clouds along some of the island coastlines (C).

Ninety-day seasonal averages are shown in figure 5. These maps reveal the extent of the equatorial cloud band near the ITCZ and show its migration and changes with season. They also show the extensive cloud minimum in the tropical eastern Pacific which is associated with the cold upwelling along the south equatorial current. Maps such as these reveal at a glance the climatology of tropical cloudiness and allow us to study the effects of long

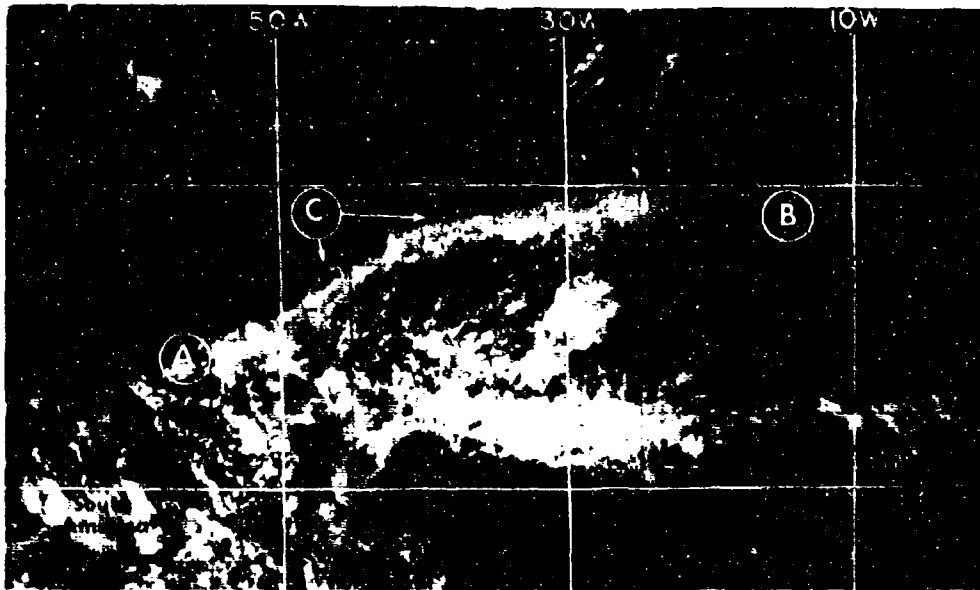

Figure 2. Subtropical Jet Stream Cloud Formation, November 19, 1968. The cloud band from A to B is associated with an upper level wind maximum and represents a poleward transport of moisture and energy from the tropics. Small-scale cloud lines (C) oriented perpendicular to the main band are typical of this formation.

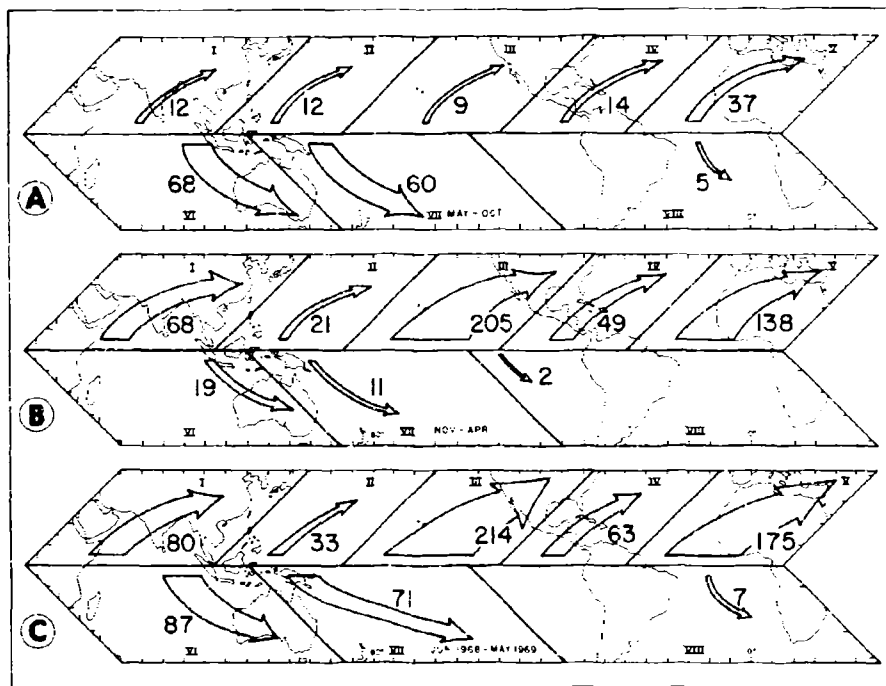

Figure 3. Number of days between June 1, 1968, and May 31, 1969, that cirrus formations associated with upper level wind maxima were observed. The occurrences tend to fall in eight natural regions indicated by Roman numerals. A and B represent seasonal occurrence, C represents the total for the year.



term variations in the general circulation.

#### V. New Data Becoming Available

Three other types of satellite data are now available on a limited basis for operational applications. These include pictures from the geostationary satellite ATS-I, temperature soundings from a multi-channelled spectrometer (SIRS) on Nimbus III and high resolution infrared (HRIR) data, also from Nimbus III.

A. ATS-I Data. The ATS satellites, positioned over the equator, take pictures of the same area at frequent intervals during the day. These pictures, when viewed in rapid sequence (movies) make it possible to watch a whole day's tropical weather develop. These data also make it possible to compute cloud velocities at both the trade wind and cirrus cloud level. Research shows that the measured cloud motions are representative of observed wind speeds<sup>(9)</sup>, and that they can be used for detailed analyses of the motion field in the tropics<sup>(6)</sup>.

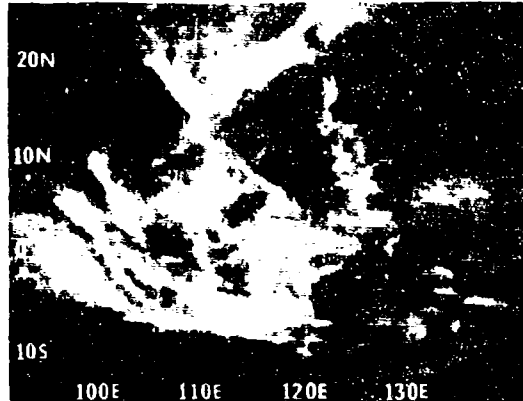

Figure 4. Thirty-day photographic average of the digitized ESSA-3 data for January 1967<sup>(8)</sup>.

ATS-I pictures (figure 6) are now being received daily at the National Environmental Satellite Center, and are then processed in the form of movie loops. Procedures are being developed to provide wind information to the National Meteorological Center on a routine basis. Movies are currently available for viewing within two hours after the final picture of the sequence is transmitted from the satellite.

The ability to view cloud changes through the day in semi-real-time is producing many new insights as to the processes which produce cloud growth and decay in the tropics. They also

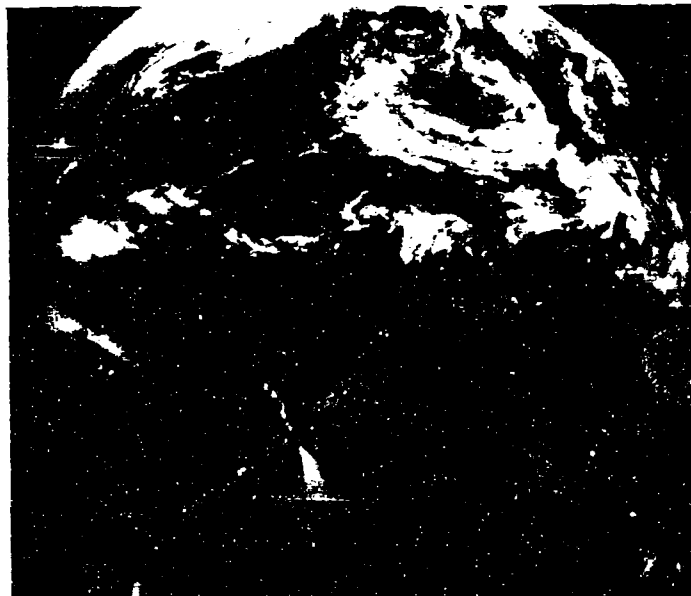

Figure 6. ATS-I picture for 2045 GMT, July 6, 1969.



Figure 5. Ninety-day brightness averages for 1967.

reveal many new phenomena which remain to be studied and explained. The effect of gravity waves on cloud fields is an example.

B. SIRS Data. A Satellite Infrared Spectrometer (SIRS) on Nimbus III provides temperature soundings (figure 7) along the satellite track for that portion of the atmosphere that is relatively free of clouds (10). Despite this restriction, a sampling rate of every 30 miles along the satellite track provides sufficient data to produce complete soundings spaced along the satellite track no further apart than four degrees latitude, or approximately one NMC grid length. These data are currently being used for the operational Northern Hemisphere analyses. Evaluation of the data is proceeding for use in the tropics and Southern Hemisphere.

C. HRIR Data. The HRIR data in the 3.4 to 4.2 channel from Nimbus III can currently be read out directly by the operational user. These data are proving useful in studies of diurnal cloud changes over the tropical oceans. We can now observe directly how diurnal changes in convection affect the cloud systems associated with weak tropical disturbances.

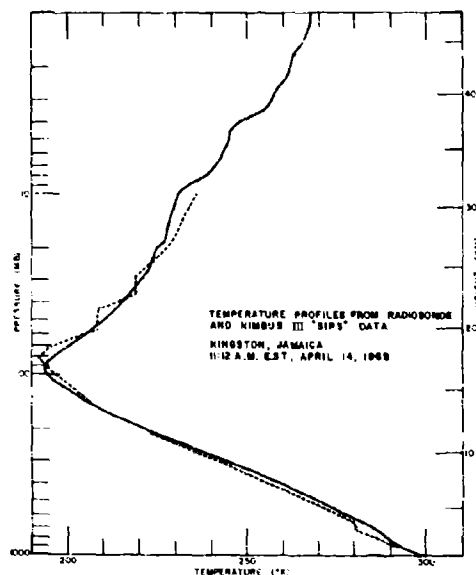

Figure 7. Sounding for Kingston, Jamaica (solid curve) obtained by infrared spectrometer on Nimbus III. Temperature sounding from radiosonde data (dashed curve) is shown for comparison.

Sea surface temperature mapping is a second important application of IR data to the tropics. Procedures are currently under development both at NESG and NASA to obtain the ocean temperatures (warmest return) by filtering out the colder return from clouds. Since large-scale ocean temperature changes occur slowly, time averaging procedures can be used. Bjerknes, in a recent paper(11) has discussed the changes in the planetary circulation which result from year-to-year in the sea surface temperatures of the eastern tropical Pacific. Smagorinsky has also pointed out the importance of obtaining sea surface temperature data on a regular basis for input into long range global prediction models(12). This type of data will certainly play an important role in the studies of tropical air-sea interaction in the immediate future.

## VI. Outlook for the Future

At the present time, ESSA-8, ESSA-9, Nimbus III and ATS-I provide daily data for input into operational analyses of the tropics. Movies from ATS-II and ATS-III, and cloud climatology produced from ESSA data, are providing new insight into tropical circulation from the convective to the planetary scale. Within the next year, our operational satellite system will provide scanning radiometer data for both day and night. Within four years, a geostationary operational environmental satellite (GOES) will monitor the earth continuously for 24 hours a day. This satellite will be equipped with sensors for the visible and infrared which will allow us to follow storms through their complete life cycle. It is now technically feasible for the daytime portion of the GOES data to have a resolution of one-half mile. The GOES satellite will also be capable of relaying information from remote sensors at the earth's surface. Other data will also be available from NASA research satellites. These developments promise to make the 1970's an exciting decade for those working in tropical meteorology.

#### REFERENCES

1. Staff, Satellite Section, ADB, ETAC and Applications Group, National Environmental Satellite Center, 1969: "Applications of Meteorological Satellite Data in Analysis and Forecasting", Air Weather Service Technical Report 212, June 1969. (In Press)
2. Jager, G., W. Follansbee and V. Oliver, 1965: "Operational Utilization of Upper Tropospheric Wind Estimates Based on Meteorological Satellite Photographs", ESSA Technical Memorandum, NESCTM-8, October 1968, 23 pp.
3. Frank, N., 1968: "The 'Inverted V' Cloud Pattern - An Easterly Wave?", Monthly Weather Review, Vol. 97, No. 2, pp 130-140.
4. Sadler, J., 1967: "The Tropical Upper Tropospheric Trough as a Secondary Source of Typhoons and a Primary Source of Trade Wind Disturbances", Hawaii Institute of Geophysics Report HIG 67-12, University of Hawaii, March 1967, 44 pp.
5. Fett, R., 1968: "Typhoon Formation Within the Zone of Intertropical Convergence", Monthly Weather Review, Vol. 96, No. 2, pp. 106-117.
6. Fujita, T. T., K. Watanabe and T. Izawa, 1969: "Formation and Structure of Equatorial Anticyclones Caused by Large-Scale Cross-Equatorial Flows Determined by ATS-I Photographs", Satellite and Mesometeorology Research Project, Paper No. 78, January 1969, Department of Geophysical Science, University of Chicago, 37 pp.
7. Fritz, S., L. Hubert and A. Timchalk, 1966: "Some Inferences from Satellite Pictures of Tropical Disturbances", Monthly Weather Review, Vol. 94, No. 4, pp. 231-236.
8. Bohan, W., and V. J. Oliver, 1968: "Tropical Atlantic (Pacific, Indian Ocean) Cloud Patterns, Climatology", 16mm film report prepared for the National Environmental Satellite Center, Contract E-184-67(N), Walter A. Bohan Company, Park Ridge, Illinois.
9. Fujita, T. T. and D. L. Bradbury, 1968: "A Study of Mesoscale Cloud Motions Computed from ATS-I and Terrestrial Photographs", SMRP Research Paper No. 71, March 1968, University of Chicago.
10. Smith, W. L., 1969: "Statistical Estimation of the Atmosphere's Geopotential Height Distribution from Satellite Radiation Measurements", ESSA Technical Report NES-48, National Environmental Satellite Center, Washington, D. C., 1969, 29 pp.
11. Bjerknes, J., 1969: "Atmospheric Teleconnection from the Equatorial Pacific", Monthly Weather Review, Vol. 97, No. 3, pp. 163-172.
12. Smagorinsky, J., 1969: "Problems and Promises of Deterministic Extended Range Forecasting", Bulletin of the American Meteorological Society, Vol. 50, No. 5, pp. 266-311.

RESULTS AND PLANS OF THE AFCRL, UNIVERSITY OF HAWAII  
1 WW TROPICAL METEOROLOGICAL RESEARCH PROGRAM

Thomas J. Keegan  
Air Force Cambridge Research Laboratories

In 1966, the Satellite Meteorology Branch of AFCRL, Hq AWS, and the Dept. of Geosciences at the University of Hawaii, under contract to AFCRL, embarked on a joint program designed to provide forecasting guides for the Vietnamese area. In order to insure effective and rapid communication between those doing the research and those in the field, the 1 WW assigned two officers full time to the University to participate in the research, bring the results to the field, train the personnel and learn the nature of problems encountered in forecasting for the multitude of operational missions. Although satellite data were relied upon heavily in the work, any and all data were exploited to develop forecasting rules. At the University of Hawaii the approach is synoptic, i.e., identifying the significant features of the circulation and how the weather responds to their variation. The approach at AFCRL has been objective and statistical. Both techniques have produced useful results which are discussed. Plans call for a continuation of this work under the present arrangement for at least another year and a half. Factors that will affect future research are the political situation in SEA, the increasing difficulty of "inventing" quick-fix solutions, and the results of discussions now being conducted between AWS and AFCRL on ways to make the research effort more relevant to AWS needs.

#### I. Introduction

The joint program among the AWS, AFCRL and University of Hawaii began in early 1966. At that time the Satellite Meteorology Branch was planning a program of research for SEA using the forthcoming Nimbus II data. (Previous satellites provided only poor coverage of that area.) The 1 Wea Wg had approached the Dept. of Geosciences at the University of Hawaii to determine if it was possible to get assistance in SEA forecasting through an AFCRL contract. Finally, the University of Hawaii was completing its commitment to the Indian Ocean Expedition and would have personnel available to work on an enlarged AFCRL contractual effort. After joint consultation, it was decided to

- a. increase the level of effort at the University of Hawaii
- b. assign 1 WW personnel to the University to participate in the research and act as liaisons to the field
- c. direct all in-house resources of the Satellite Meteorology Branch to SEA studies

All these objectives have long since been achieved and the program is now nearing the end of the third year of what is generally agreed to be a successful effort.

To forestall any confusion that might arise, I want to point out that this program is not what some would consider research in tropical meteorology or satellite meteorology. It is a study designed to provide analysis and forecasting aids for the AWS units working in and for the SEA area. In the sense that SEA is in the tropics, knowledge of tropical meteorology is both exploited and expanded. All sources of data are used but because of the particular interest in satellite data, they receive some extra consideration.

The program can be broken down into 4 phases as follows:

- a. Forecasting research at the University of Hawaii which is oriented towards the synoptic-analytical approach

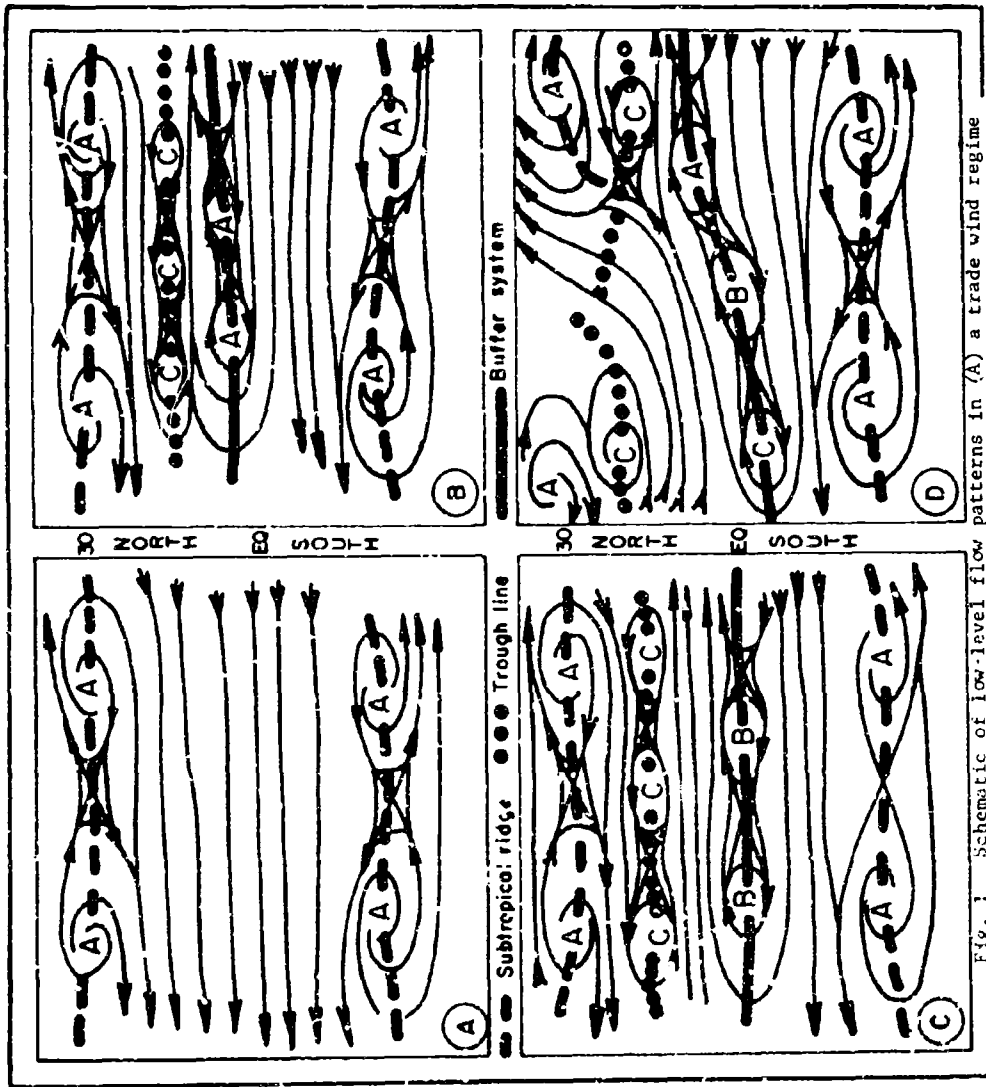

Fig. 1 Schematic of low-level flow patterns in (A) a trade wind regime and (B) a monsoon regime during northern summer. Charts B and C illustrate the necessity for a buffer zone if a trough line is introduced between the subtropical ridges.

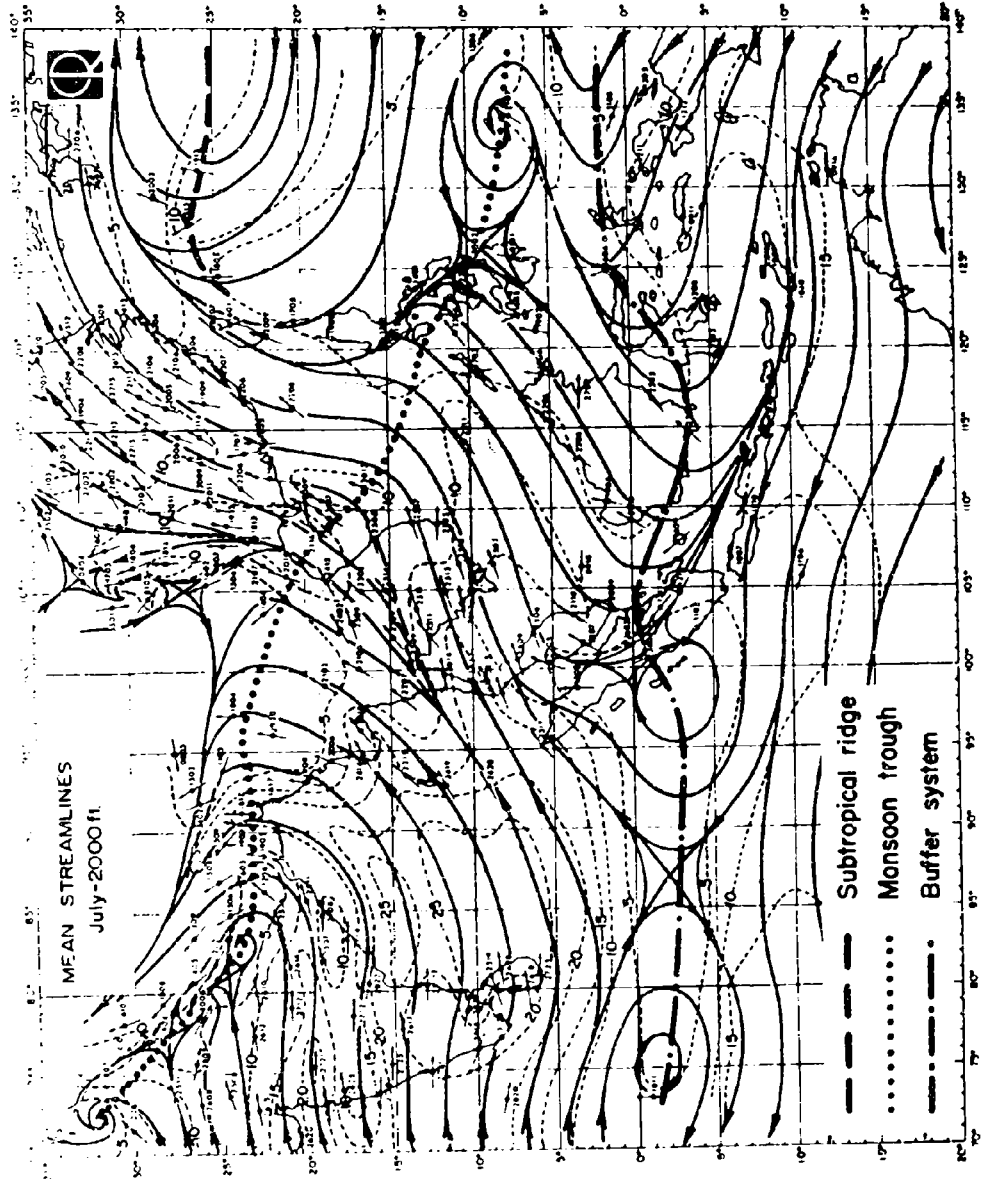
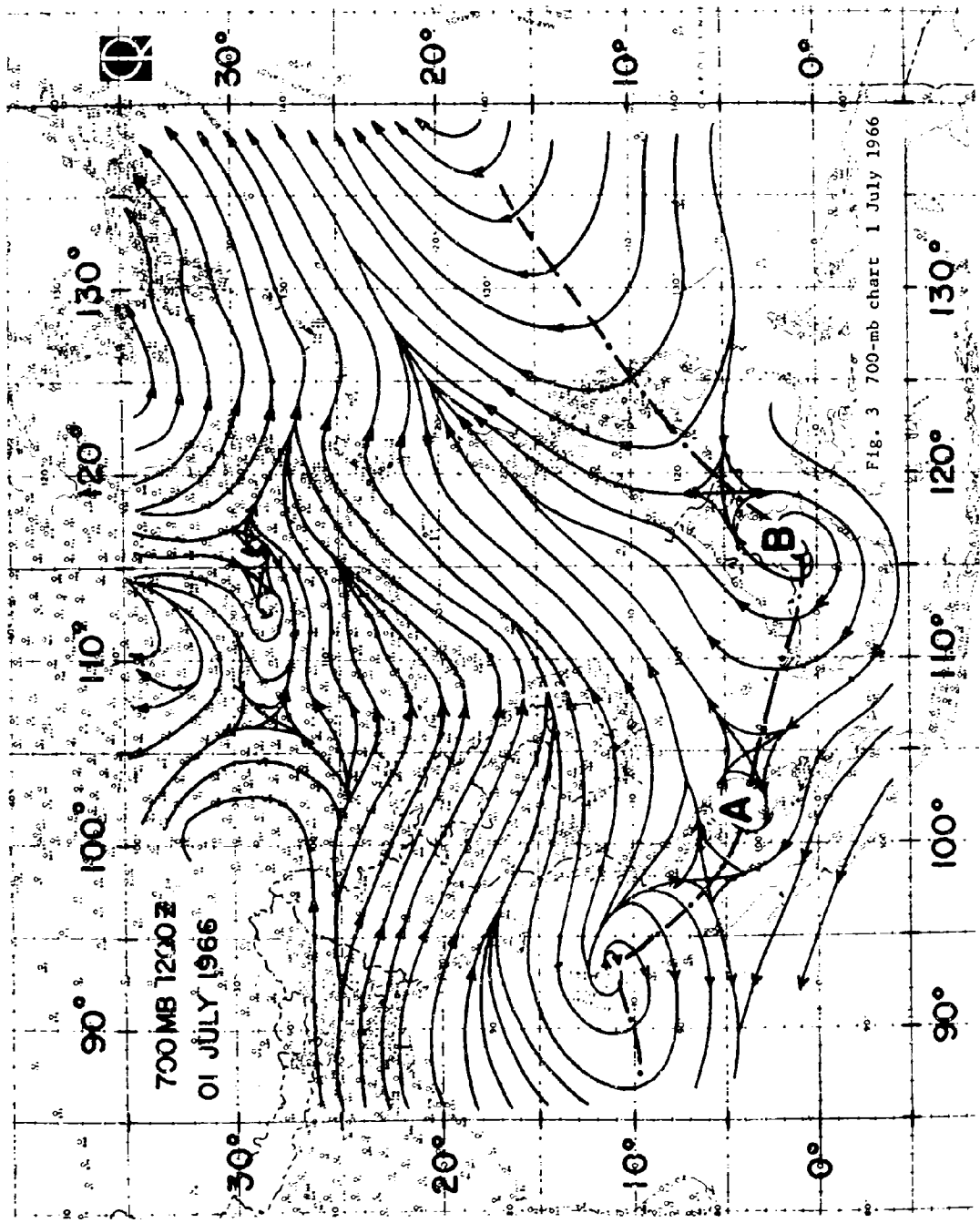
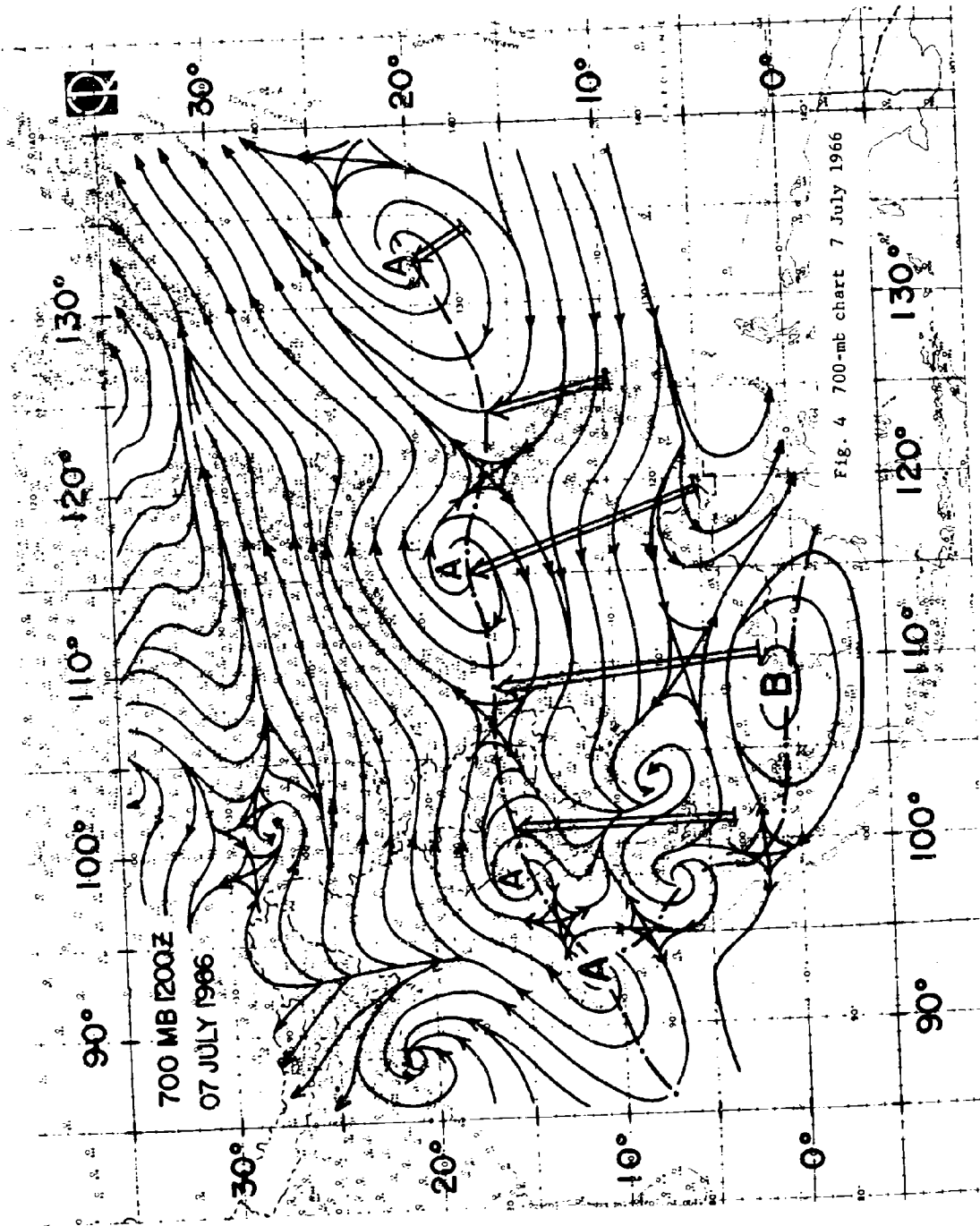

Fig. 2 Resultant streamlines for July at 2000 ft.







- b. Forecasting research at AFCRL which is objective-statistical in nature
- c. Development of techniques at AFCRL for optimizing APT products
- d. Training of AWS personnel in results of forecasting research and APT optimization

## II. Forecasting Research at the University of Hawaii

Professor James Sadler is Principal Investigator at the University of Hawaii. In addition 2 officers from Hq 1st Wea Wg are assigned full time duty at the University. Currently, they are Lt. Col. Brett and Major Harris.

The thrust of the work at Hawaii is towards utilizing the features of the synoptic analysis to specify and predict the weather (1, 2, 3, 4). Emphasis had been placed on target areas in the north. The satellite data are used in research to define the weather conditions and assist in the analysis. Operationally, they are used for improving the map analysis. The approach is to determine what features of the circulation bring about changes in the weather and then to establish the predictability of the key circulation changes. In other words, the aim is to develop a series of synoptic models for the area.

One of the shortcomings of this approach is that the personnel in SEA are for the most part inexperienced in the tropics in general and SEA in particular and with only a year on duty there, they do not have much time to exploit the experience they gain on the job. Fig. 1 is taken from training material prepared at Hawaii and illustrates the major synoptic features of the southwest monsoon season. Fig. 1A shows a simplified trade-wind flow with subtropical anticyclones north and south of the equator. In Fig. 1B, the introduction of a trough between the anticyclones requires that a second clockwise system be introduced. Sadler calls this system the buffer anticyclone. If the features of Fig. 1B are moved southward, the buffer anticyclone could be located on the equator as in Fig. 1C, and can be called neither a cyclone nor anticyclone. Fig. 1D shows a more realistic circulation regime for the SEA area with the major synoptic features - the subtropical anticyclone, monsoon trough and buffer system identified.

Fig. 2 brings us closer to reality with an illustration of the July, gradient-level, resultant streamline chart. Again the major features of the circulation are indicated. It is the change in location and intensity of these features as illustrated in the next two charts that brings about changes in the weather. Fig. 3 shows the 700-mb chart for 1 July 1966. Strong mid-latitude westerlies have forced the western end of the subtropical ridge far to the south and have "tied" it in with the buffer system. The monsoon trough, what there is of it, is oriented N-S along the east coast of Vietnam. Six days later, (Fig. 4) the anticyclonic system has rotated northward about its eastern end and extends across SEA into the Bay of Bengal. The monsoon trough ends at the northern coast of the Bay of Bengal and a new buffer circulation has formed near Singapore. It turns out that this particular sequence of northward advance of the buffer system is associated with a singularity. During the first two weeks of July there is a dry spell in southern China which has been exploited since ancient times to harvest the first rice crop of the year. It also brings several consecutive days of clear weather to the Hanoi region.

Another event which brings clearing to the north is the presence of a tropical storm or typhoon within the area, 15N to 25N and 115E to 130E. This clearing is associated with subsidence in the ridge ahead of the storm and is effective unless the remains of a previous storm are still affecting the southern China or Vietnam areas.

During the winter, northeast monsoon clearing is infrequent and of generally short duration. However, as in summer, the key is in "ridging" or the development of an anticyclonic flow over

TAN SON NHUT 1967

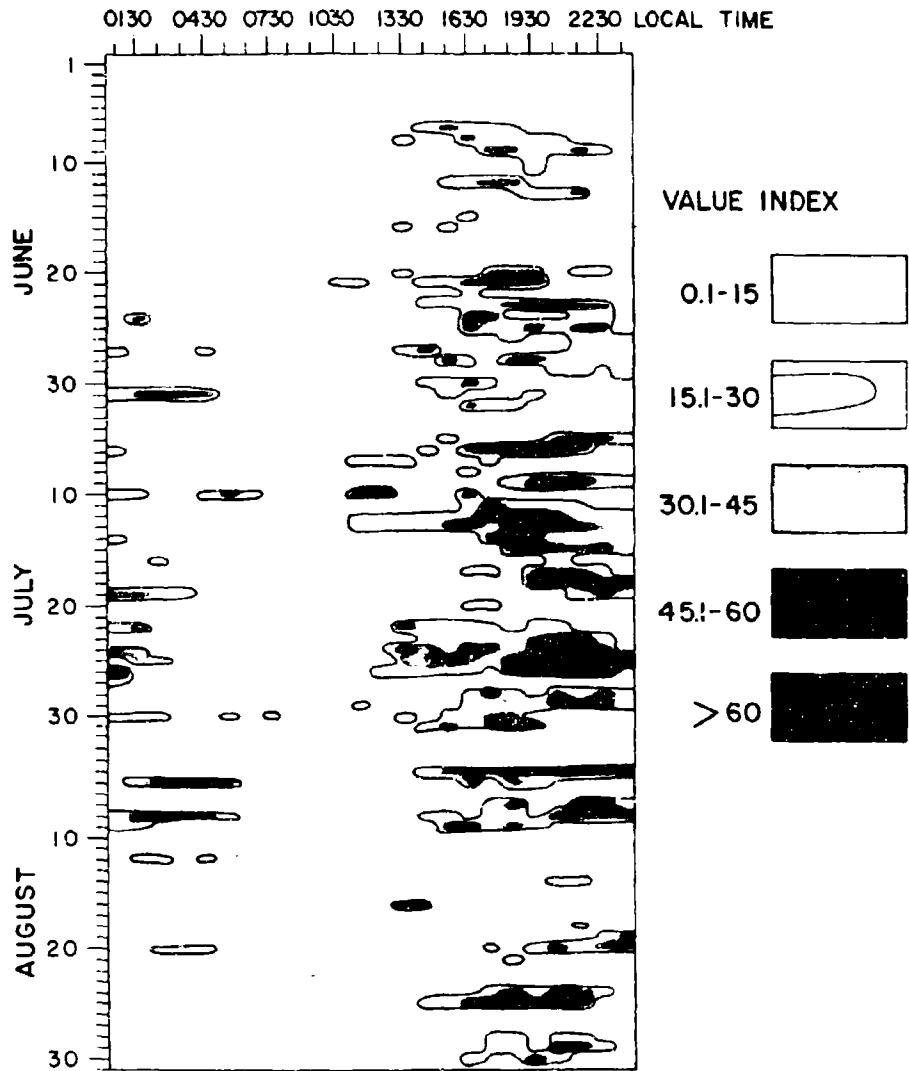

Fig. 5 Hourly Radar Index at Tan Son Nhut for June, July, August 1967

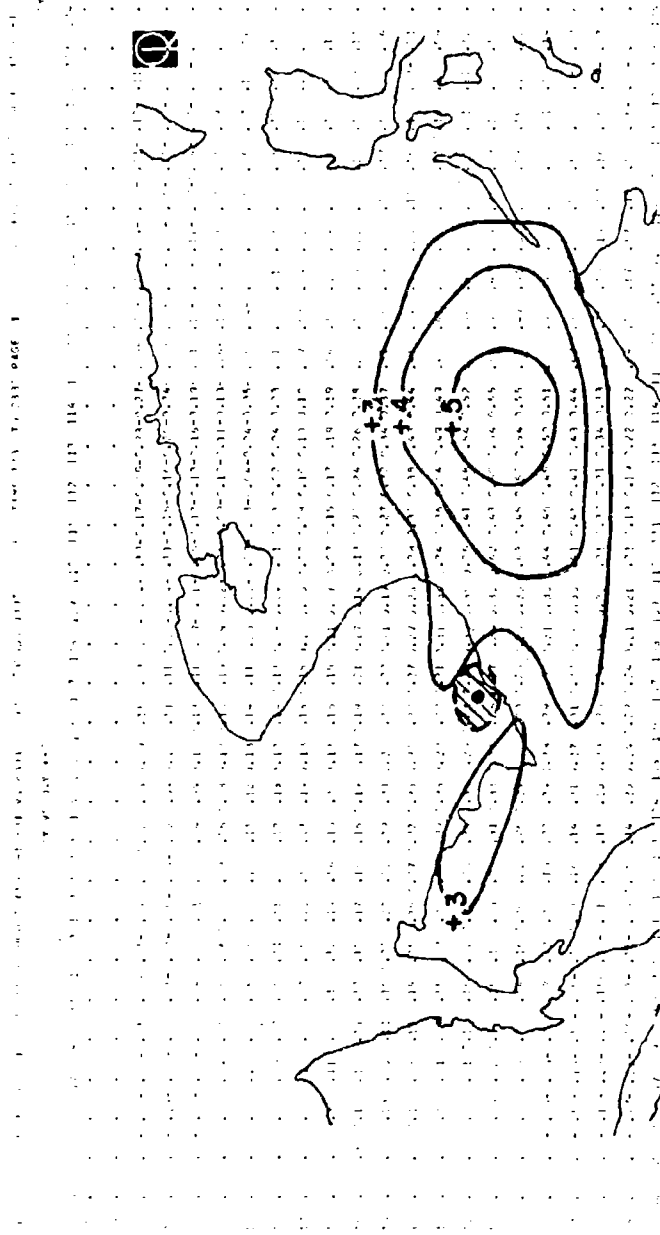

Fig. 6 Correlation coefficients between average Radar Index from 1230 to 2330 local time at Tan Son Nhut and cloud cover near local noon for June - August, 1966-1968.

SEA which causes a reversal of the low-level winds to an offshore direction.

### III. Forecasting Research at AFCRL

At AFCRL the approach has been statistical in nature with the hope of developing some forecast guidelines which could be applied objectively. We have concentrated on the southwest monsoon season and on the forecasting of rainfall. Because of the unrepresentativeness of point rainfall in a showery tropical regime, an area rainfall index was developed by John Conover. It is called the Radar Index (RI) and is per cent echo coverage on a radar scope within the 50 n. m. circle of the station. The echo areas are weighted according to whether the echoes are reported as widely scattered, scattered, broken, solid or cells. RI data are available from Tan Son Nhut, Pleiku, Ubon and Udorn. The RI has proven to be a good indicator of the level of storminess on a particular day. Fig. 6 illustrates the hourly variation of the RI at Tan Son Nhut for the summer of 1967. The presentation is arranged so that the diurnal variation can be seen. It is evident that, although there is a strong diurnal effect, there is also considerable variation in the timing and intensity of the rainfall.

One of our studies explored the relationship between the cloud cover as portrayed on satellite pictures and the RI during subsequent periods. Correlations were run for clouds vs. 3-hour average RI out to 24-hours and vs. 12-hour average RI out to 7 days. The cloud cover was quantized by determining the average cloudiness over 1-degree squares from the pictures, averaging this value over overlapping 4-deg squares and computing the correlation for each 1 deg.

Fig. 6 illustrates the distribution of correlation coefficients for Tan Son Nhut for the 12-hour period from 1230 to 2330 local time. The maximum correlation coefficient is 0.55. The elongated shape of the correlation maxima agrees with the location of a cloud band that was noticed on satellite pictures during active days before any computations were performed. Regression equations have been computed for the relationship between subsequent RI and the point of maximum cloud-cover correlation. Based on one year of dependent and one year of independent data, the predictions for 12 hours at Tan Son Nhut and Ubon were an improvement over persistence of the previous day's RI and climatology. At Udorn they were better than persistence, and at Pleiku persistence was the best predictor.

Figure 7 shows the mean gradient-level streamline charts for high and low (tertile 1 and 3) RI days at Tan Son Nhut on the top and the corresponding average cloudiness on the bottom. Cloudiness is coded 1.0 for clear and 3.0 for cloudy. Thin cirrus clouds were not included in the computation. Notice that in agreement with results at the University of Hawaii, the active days are associated with west winds south of the monsoon trough. On inactive days the wind has a more southerly component. For the four stations studied the monsoon trough was 6 to 7 deg north of each station on active tertile 1 days and weak and far to the north on tertile 3 days.

It is not possible to discuss all the facets of the work we have done along these lines but note should be made of some of them. For example, relationships have been established between cold cloud areas in the infrared and subsequent R.I. The general area and value of the maximum correlation coefficient corresponds with that of the daytime correlations.

A simple, but effective, relationship has been established between the early morning gradient-level speed and the height of radar echoes in the vicinity during the afternoon and evening. Paradoxically, days when the radar echoes exceed 45,000 ft are not generally those categorized as active by the R.I. This may be a result of widespread storminess preventing the generation of extreme convective circulations. Studies by Major Harris (3) showed that the soundings in SEA were more convectively unstable during inactive than active R.I. days.

# TAN SON NHUT

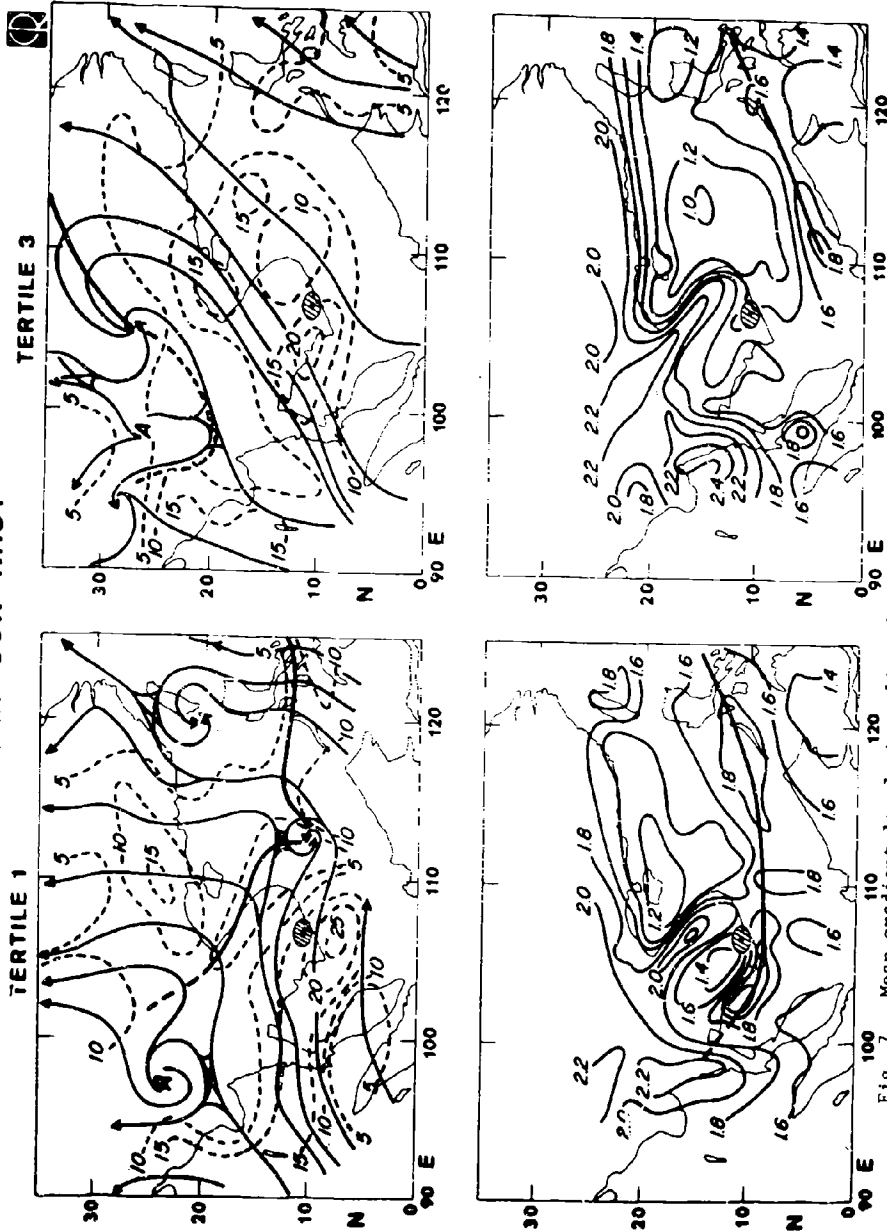

Fig. 7 Mean gradient-level streamline charts for tertile 1 and 3 (active and inactive) days at Tan Son Nhut (top) and corresponding cloudiness (bottom). Cloudiness is coded 1.0 for clear and 3.0 for overcast.

# MUIRHEAD APT PHOTOFACSIMILE RECORDER

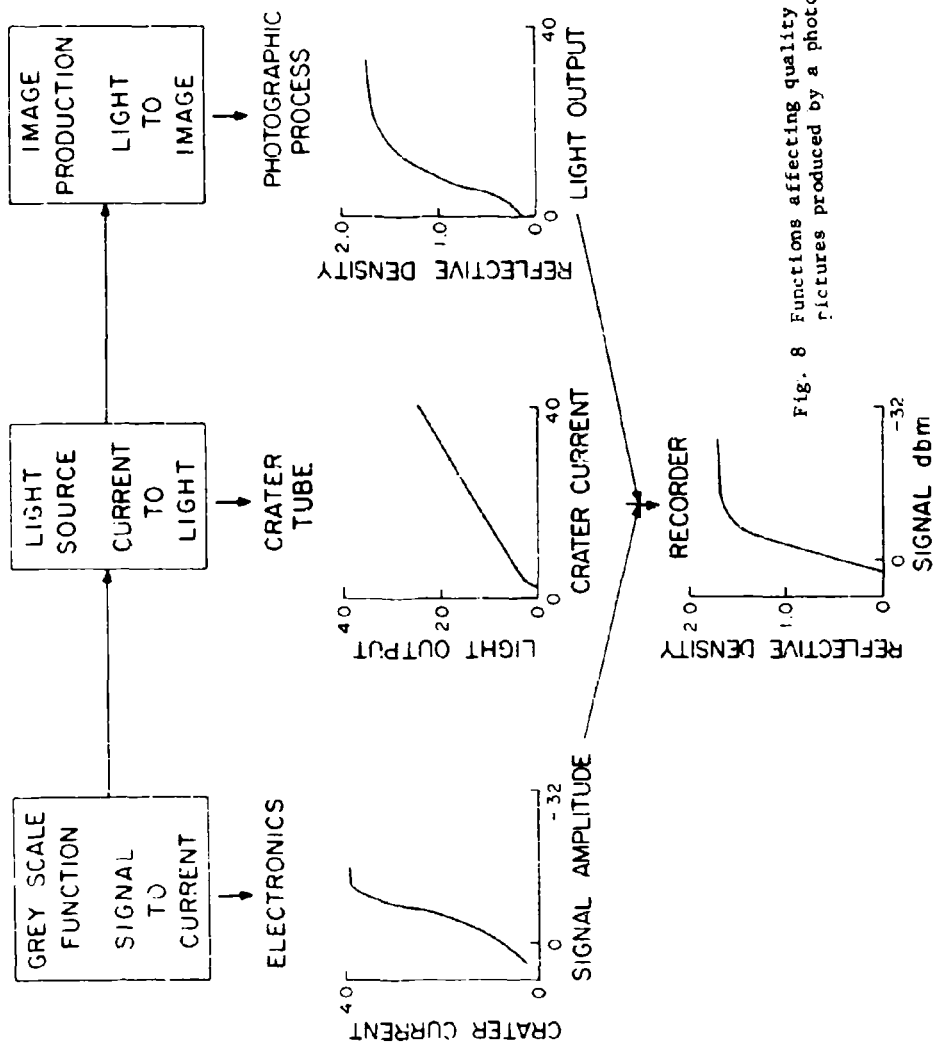

Fig. 8 Functions affecting quality of satellite pictures produced by a photofacsimile

Results of in-house work have been prepared in manuscript form and sent directly to the field. A printed version will appear in (5).

At Pennsylvania State University, AFIT students working with Army artillery data have produced several interesting theses. Capt. McKechney did a power spectrum analysis of winds, temperatures and pressures. The peaks occurred at 24 hours and at 5 days. This latter period coincides with several other apparently unrelated phenomena. For example, the RI - cloud cover correlation drops steadily after 24 hours but shows a small but significant increase at 5 days. Reanalysis of work of Frolow (6) indicates that a 5-day pressure wave is found in the Caribbean. Frolow's wave had a velocity of 68 kts. Maruyama (7) found waves in the lower stratosphere with a speed of 50 kts and Conover has analyzed pressure changes in SEA which indicate a wave moving from the east at 60 kts. The general correspondence in the timing of these various phenomena lead one to wonder if such a large scale effect contributes to the triggering of weather changes in SEA when combined with the proper synoptic conditions.

#### IV. APT Optimization

Contact with personnel from the 1 Wea Wg has convinced us of the importance of satellite data for the remote areas in which they operate. Unfortunately, APT has grown in a rather undisciplined manner and this shortcoming is compounded in the military because operating and maintaining an APT is not a full time job and most personnel do not continuously accumulate experience. Manuals are available on the maintenance of the equipment and the interpretation of pictures but again, unfortunately, a properly maintained set can produce pictures which defy interpretation. This is because each satellite has had slightly different videcon responses and as the videcon ages this response changes. Nimbus II, for example, when it was launched had a range of signal amplitude from 0 dbm for white to -32 dbm for black. A year later it was +3 dbm for white and -5 dbm for black. A facsimile which would produce a good picture when the satellite was new could give only a white smear a year later.

An electronic device was produced to enhance the pictures but the operating instructions were vague and no systematic procedure for optimizing pictures was presented.

Our emphasis has been on the Muirhead photofacsimile because this equipment is available in SEA. Techniques have been developed by Mr. Robert Myers of AFCRL (8) for the optimization of pictures. The Muirhead has built into it the necessary flexibility to adjust the marking current or, in this case, crater tube current to produce a good picture under almost any conditions.

What has been done for the Muirhead is to develop a procedure which details how to determine the relationships between (Fig. 8)

- a. cloud brightness and satellite signal amplitude or the image to signal conversion function
- b. signal amplitude and crater current, or the gray scale function
- c. crater current and light output or condition of the light source
- d. light output and reflective density or image production function

All of this can be done internally on the machine with the exception of step a. This has to be done experimentally by reading brightness values from a picture and a test gray scale with a reflective densitometer. We have provided these instruments at four sites in SEA. The actual setting of the gray scale is done by putting the appropriate signal amplitude - crater current relationship into the machine by means of a series of potentiometer adjustments. This can be a somewhat tedious task, since the potentiometers do not function independently,



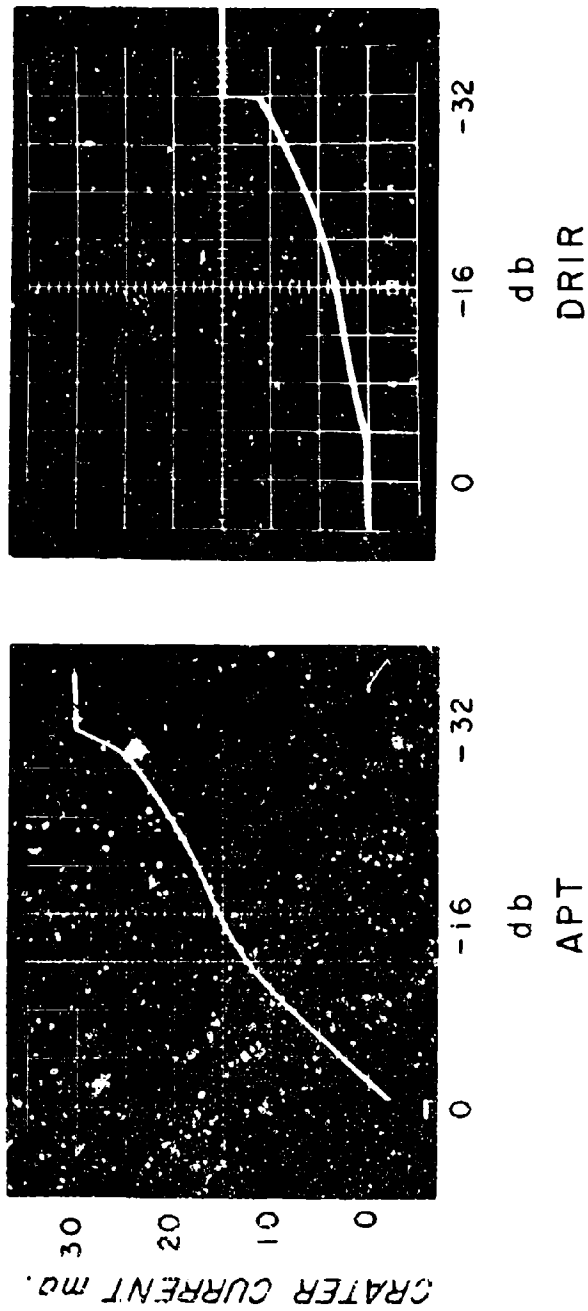

Fig. 9 Oscilloscope display of crater current and signal amplitude for sample APT (left) and IR transmissions.

and the values must be reached by an iterative process. To overcome this difficulty, Mr. Myers and Mr. Sprague have designed and built a device that allows the signal-crater current curve to be displayed on an oscilloscope. If the desired curve is plotted on the face of the scope in grease pencil, it only takes a few minutes to set the relationship into the machine since the effect of each potentiometer adjustment can be immediately seen. Fig. 9 shows typical APT and DRIR curves as they appear on the scope. The DRIR curve is much more critical because small changes in crater current produce large changes in reflective density since the scan speed is only one-fifth of the APT.

We are having five of these devices and the display oscilloscope produced for distribution to Muirhead sites in SEA. They should be delivered by October.

In passing, it should be noted that this calibration technique makes it possible to get quantitative temperature values from DRIR presentations if the satellite radiometer system functions are stabilized.

#### V. Training of Field Personnel

Communication of results of the joint SEA program to operational personnel is a continuous process and utilizes a significant fraction of the total resources. Since the summer of 1967, the 1st Wea Wg officers assigned to the University have alternated on quarterly trips to Saigon to bring the latest results to the field. Prof. Sadler has accompanied them on several occasions. They spend approximately two weeks conducting seminars, providing individual assistance to forecasters and standing forecast shifts to assist in the application of the techniques to real situations. On several occasions, they have been able to provide forecasts on which the Air Force planned and executed maximum-effort missions. Following Saigon, they visit the 20th Wea Sq at Fuchu to present the techniques and provide consultation on how the weather central might be able to give additional assistance to the detachments.

Forecasters on their way to SEA stop at Hawaii to receive a cram course in the specifics of SEA analysis and forecasting. Charts plotted for the research have been sent to Chanute for use in their tropical training program.

All parties involved have participated in the annual APT Workshops held by 1 Wea Wg. These meetings have been especially useful for informing the field personnel in what they can expect from their APT sets and how to get it. In conjunction with these meetings, Mr. Myers has made visits to Saigon, Okinawa, Fuchu and Hickam to provide assistance and training in APT maintenance and picture optimization.

At AFCRL, on five occasions so far, we have provided individual instruction to AWS and AFCS personnel on the techniques for optimizing Muirhead picture quality.

Finally, last April, in association with the Navy Weather Research Facility, we held a two-week seminar workshop on the southwest monsoon. One of the highlights of that meeting was that the AWS arranged to have men attend who were not yet on duty in SEA, but who would be there this summer.

#### VI. Future Plans

This joint AFCRL-AWS-University of Hawaii program will definitely continue through CY-70. What happens beyond then will be affected by national, AWS and AFCRL priorities. I believe that there are good reasons to keep the concept of such a cooperative venture going. From the comments we have received informally from various AWS echelons, they consider this a very

successful effort.

The prospects of finding "quick-fix" forecast techniques is diminishing. Future progress is going to depend on a better understanding of the physical processes which are responsible for the weather. For example, there is poor correspondence between clouds and computed vertical motions at a point. There is also no relation between the RI and computed vertical motions. Since convective clouds are visible evidence that upward motion is taking place, the suggestion is that we cannot hope to diagnose or forecast this scale of phenomena with the present upper air network. There are other features which should be investigated such as the possibility of a diurnal sea-breeze type oscillation which some preliminary evidence indicates affects the entire SEA peninsula. Also, the large-scale pressure waves mentioned earlier should be subject to further investigation. Undoubtedly, it is some subtle combination of several scales of events which bring about the weather changes. Since the SEA area has one of the better data bases in the tropics, it would seem to be an ideal place to do research, regardless of the political situation.

Certainly, we hope to continue the consultant program with the help of AWS. Even without the development of any new techniques, there is still a service that can be performed here for quite a while to come.

As things stand now, it seems likely that the joint program will continue for an indefinite period but hopefully no longer than it proves to be a useful arrangement. Adjustments will be made in the approach to the problem and also in the level of effort as the situation demands.

#### VII. Conclusion

The aim of this joint program is to develop some useful guides for forecasting in SEA. In this we have achieved a degree of success. We have provided a series of guidelines which when combined with other available techniques, should provide greater confidence (or some confidence) in choosing the direction the forecast should take. Procedures have been developed to improve the ability to interpret satellite data. A "personalized" consultant service has been made available to the field units. In addition, we have gained new insight of the complexities of tropical weather and are now able to suggest avenues for further exploration. We would like to continue working on this puzzle. Certainly, there can be no question of the success of the concept of the joint program. The cooperation among the AWS Detachments, Wings and Headquarters, the University of Hawaii and AFCRL is a credit to all.

Acknowledgements- In addition to those specifically mentioned in the text, I would like to extend my appreciation to Messrs. Francis Valovcin, Rupert Hawkins, James Bunting, SSGTS John Hart and Barry Mareiro, all of whom contributed to the studies. I would also like to thank Mr. Richard Sizer for the illustrations prepared at AFCRL and Mrs. Helen Angier for the typing of the manuscript.

#### REFERENCES

- [1] Sadler, J., W. Brett, B. Harris and F. Ho: Forecasting minimum cloudiness over the Red River delta during the summer monsoon; Scien. Rept. No. 1, Cont. F19628-67-C-0232, Hawaii Inst. of Geop., AFCRL-68-0487, 104 pp, 1968
- [2] Danielsen, E. and F. Ho: An isentropic trajectory study of a strong northeast monsoon surge; Scien. Rept. No. 2, Cont. F19628-67-C-0232, Hawaii Inst. of Geop., AFCRL-69-0036, 13 pp, 1969

- [3] Harris, B. and F. Ho: The structure of the troposphere over southeast Asia during the summer monsoon month of July; Scien. Rept. No. 3, Cont. F19628-67-C-0232, Hawaii Inst. of Geop., AFCRL-69-0081, 18 pp, 1969
- [4] Harris, B., J. Sadier, W. Brett, F. Ho and G. Ing: The role of synoptic scale convection over southeast Asia during the summer monsoon; Final Report, Contract F19628-67-C-0232, Hawaii Inst. of Geop. AFCRL-69-0131, 35 pp, 1969
- [5] Ramage, C., editor: Proceedings of the joint Air Force Navy southwest monsoon conference - Workshop, April 7-18, 1969, Honolulu, Hawaii, to be published, 1969
- [6] Frolow, S: On synchronous variations of pressure in tropical regions; B. Amer. Met. Soc., 23:239-254, 1942
- [7] Maruyama, T.: Large-scale disturbances in the equatorial lower stratosphere; J. Met. Soc. of Japan, 45:391-408, 1967
- [8] Myers, R.: Factors affecting the APT picture quality; Instrumentation Papers No. 149, AFCRL-68-0517, 21 pp, 1968

## AIR WEATHER SERVICE AND WEATHER MODIFICATION

Thomas A. Stuler  
Major USAF  
Air Weather Service

This paper will review the Air Weather Service field program in fog modification that was carried out during the winter 1968-69, will outline the objectives for this coming year's work, and will sketch very briefly the advances that we hope can be made towards achieving expanded operational capabilities in the early 1970s.

### I. The Program in FY 1969

It should be noted, and the FY 69 program illustrates this, that Air Weather Service does not have an R&D mission as such. Our efforts are geared to applying operational capabilities or to doing operational testing on techniques that are intended to become operational capabilities. For this reason our program is currently confined almost entirely to cold fog modification. No other aspect of weather modification is yet ready for military employment.

Primary emphasis was given to continuing operational support to air traffic transiting Elmendorf AFB, Alaska (EDF). The major portion of this traffic is C-141s enroute to, or returning from, Southeast Asia carrying cargo and medical evacuees. Supercooled fog is the greatest single weather-originating cause of interruptions to the orderly flow of this traffic.

A single WC-130 from the 54th Weather Reconnaissance Squadron based at Guam was positioned at Elmendorf from mid-November to the end of February and carried out seeding operations whenever supercooled fog interfered with scheduled inbound or outbound aircraft.

Dry ice was used primarily as a seeding agent. Dry ice blocks weighing approximately 10 lbs were fed into a hammermill crusher. The crushed ice was collected in a hopper from which it was automatically delivered by a motor driven auger via a slender pipe to a funnel placed in the dropsonde chamber. A variable-speed motor permitted selection of any dispensing rate desired.

Seeding patterns were flown upwind of the approach and touchdown area of the runway. Individual lanes were spaced approximately 3000 ft apart. It was necessary to make the patterns much larger than actually required because it was so difficult to predict the direction and speed at which the seeded fog would drift.

We were very pleased with the results of seeding at Elmendorf this year. As near as can be estimated, approximately 180 aircraft landings were made possible and a further 155 takeoffs were assisted. The dollar savings in operating costs are evident when it is considered that to divert an aircraft at Elmendorf costs anywhere from \$500 to \$1000 or more.

Silver iodide flares were used in tests to determine if they are as effective as dry ice as seeding agents for cold fog. ATO bottles were modified by the Naval Weapons Center to hold five individual flares that were electrically ignited from the copilots position. Each flare burned for two minutes.

As far as it was possible to determine AgI worked as well as dry ice when it was dispensed either in the top of the fog or no higher than 200 ft above the top of the fog. All tests were conducted at temperatures less than -5°C.

Central and northern Europe also experiences considerable supercooled fog during the winter months, although, unlike Alaska, the temperature of this cold fog is almost always warmer than -5°C. To gain some idea of how effective cold fog seeding would be to support military operations in Europe, a WC-130 carried out seeding operations for three months at three airbases in West Germany's Eifel forest area.

These bases were Hahn, Spangdahlem, and Bitburg. The fog that occurs at these sites can be very dense and persist often for extended periods of time. Hahn AB for example was below approach minimums in fog for the major portion of the first eight days of last December. Oddly enough the surface wind during this period was frequently in excess of 10 knots.

We learned two basic things from these seeding operations in Europe. First, it was clearly shown that dry ice can create a useful clearing in fog even when it is very dense and deep, when it is accompanied by strong winds, and when its temperature is near 31°F.

Secondly it was learned that measuring the effects of seeding in even, homogeneous, fog is much easier than doing so in patchy, non-homogeneous fog.

To complement the work being done using aircraft to seed cold fog, operational testing was done with ground propane systems at Fairchild AFB, Washington. Similar tests were also carried out at Kingsley Field, Oregon.

Trailer-mounted dispensers were used to vaporize liquid propane at pre-selected rates into the fog. Our goal in these tests was to learn more about the problems connected with siting dispensers to compensate for winds and to determine the minimum number of dispensers required. These dispensers were mobile and their placement was decided on just prior to each test on the basis of the forecast winds.

The general results of these tests were encouraging, but it did become evident that using dispensers in a mobile mode is simply not practical. We intend to re-design this system before proceeding further.

In addition to the work in cold fog, a short evaluation was made to learn if sized hygroscopic material forced upward from the ground was promising enough to be engineered into an operational capability to dissipate warm fog.

A single vertically-pointing blower was used to inject the material. Tests were conducted at Travis AFB. Lack of fog severely limited testing, but the little accomplished did suggest that further R&D work should be carried out before operational testing is continued.

## II. The Program For FY 70

During the coming year our efforts will have four goals:

a. Apply airborne dissipation of cold fog and stratus to a broader cross section of operational requirements. It is now planned that two WC-130s will be positioned at EDF to support stated requirements of the Alaskan Air Command and the US Army Alaska. First priority will be given to dissipating supercooled fog at Elmendorf AFB. Similarly two WC-130s will be positioned in Europe to provide operational support to tactical-fighter and photo reconnaissance aircraft at four air bases in West Germany. These bases are Hahn, Spangdahlem, Bitburg, and Ramstein. In addition operational testing will be carried out at several air bases in England to determine if its possible to dissipate the type of supercooled fog that occurs in the United Kingdom. The principal objective of these programs will be to eliminate supercooled fog as a problem that must be considered by commanders when planning, scheduling, or carrying out their operations. At Elmendorf, for example, the overriding goal will be to reduce to zero the number of aircraft that are forced to divert because of supercooled fog.

b. Continue operational testing of a ground propane system for dissipating cold fog to arrive if possible at a reliable system that can be implemented operationally. This testing will be done at Fairchild AFB, Washington. A system of 20 individual dispensers will be placed in and near the base complex. Dispenser sites will be chosen to compensate for the most frequent wind speeds and directions that occur with cold fog. The Strategic Air Command will provide engineering and procurement assistance and the Army Corps of Engineers, Seattle District will arrange for the lease of off-base property.

c. Develop more objective methods for computing the cost benefit ratios of fog dissipation in terms of operating dollars saved or of direct assistance towards carrying out an operational mission. Military operations do not lend themselves so well to this as the more regularly scheduled commercial airline traffic does. Such methods are needed, though, and will be particularly useful when warm fog capabilities are ready to be phased into

operational use.

d. Monitor carefully the progress being made in warm fog research particularly in the field testing of techniques to dissipate warm fog on a small scale.

The Program in the early 1970s. At this time it can be stated that military interest in weather modification in the early 1970s will be focused primarily on the problems caused by stratus and fog, both supercooled and warm. Reduced visibility, particularly when this is thought of as horizontal, slant, and vertical visibility, has a more serious adverse impact on military operations than any other single weather factor. This fact has been well documented and I'm sure will not come as a surprise to anyone. Though other weather phenomena such as precipitation and haze, reduce visibility they do so on a much smaller scale than stratus and fog.

We recognize that calling attention to the importance of fog and stratus is only a first step in defining the requirement for those who are to research and develop operational techniques. The varying circumstances under which fog and stratus become a problem must be outlined more clearly. Much more work along the lines of operational analysis is needed to identify the magnitude of these problems in terms of mission impact or cost-loss statements.

In general we can say that by the mid-1970s we expect to have cheap, reliable, ground-based systems for dissipating cold fog that can be installed easily at air terminals or fixed operating locations that experience problems with cold fog. We expect to maintain an air-borne capability to dissipate cold fog that will be used in tactical training situations and at fixed locations with substantial cold fog problems that are not amenable to the lower-cost ground system.

We hope to have ground systems for dissipating warm fog that can reliably create landing conditions of at least 100 ft/1/4 mile in winds up to 5 - 10 knots. It is to be expected that the cost of this capability will, at least initially, confine its use to air terminals with high density traffic. A great deal of effort has already been expended in investigating Category III landing systems. It has become evident that to achieve a true zero-zero landing capability or anything approaching a routine basis will require costly and very sophisticated landing aids. The technical problems yet to be solved are considerable. The greatest problems are associated with enabling complete "hands-off" during the final flare and touchdown portion of flight. If sufficient visibility could be assured so that the flare and touchdown could always be accomplished by a pilot the requirement for what will be the most costly landing aids could be removed and the safety of the operation would be greatly enhanced.

The manner in which other weather modification capabilities, such as precipitation stimulation and hail or lightning suppression, will be applied to support military operations is not yet defined. Their value to agricultural and forestry interests is obviously great. It seems evident that at least after they are developed, if not before, important military uses will be found for them. These potential uses should become more clear as R&D work goes on.

Of equal interest to us at this time, along with the development of other weather modification techniques, is the achieving of more sophisticated means to judge the actual effects, long and short range, of actions taken to modify the weather. Not only is this important to the employment of weather modification capabilities, but is essential for estimating the effects that possible efforts by unfriendly powers to alter our weather might have.

This summarizes briefly the primary areas in which Air Weather Service will be interested in the next several years. The progress and discoveries in cloud physics and numerical modeling and prediction may well permit us to expand our horizons of operational application.

## LIGHTNING SUPPRESSION

Donald M. Fuquay

U.S. Department of Agriculture, Forest Service,  
Intermountain Forest and Range Experiment  
Station, Ogden, Utah 84401; stationed at  
Northern Forest Fire Laboratory  
Missoula, Montana

Various approaches to deliberate lightning modification or suppression are reviewed. Two methods, chaff seeding and silver iodide seeding, have received theoretical, laboratory, and limited field study; these are discussed in some detail.

A test of the efficacy of silver iodide seeding in lightning modification, conducted by the U.S. Department of Agriculture, Forest Service, is described. Results suggest that seeding decreases lightning frequency and alters certain characteristics of individual discharges.

### 1. Why Suppress Lightning?

That modern society needs adequate lightning protection is well known. Lightning rods, the standard means of protecting man and his structures since the days of Benjamin Franklin, simply cannot be adapted to some of today's requirements. For example, we have no way of protecting a space vehicle through critical periods of launch and early flight.

This is not to say that the space program is alone in its need. Many military and industrial activities may be too large, too small, or too temporary to warrant the time and expense of standard lightning protection measures. Transient operations often present particularly difficult protection problems. A single lightning discharge could be disastrous to some hazardous procedures, such as the handling of fuel or explosives. Warning devices can signal the approach of thunderstorms, but local storms can mature to the lightning stage in minutes. When this happens, it is not always possible to secure operations before the first discharge; so protective measures must be immediate and totally effective.

## II. Approaches to Lightning Suppression

According to extant theories, most of the physical events that take place within a cloud system influence electrification. No one as yet has identified the predominant mechanisms governing cloud electrification and discharge processes, but evidence leads me to assume that a change in any one of the physical or dynamic properties of a cloud could affect electrification. For example, cloud seeding to increase precipitation might result in a change in lightning intensity. It has been proposed that lightning can be modified by triggering discharges, by changing cloud development, or by altering electrification processes.

1. Triggering Discharges. A lightning discharge is induced at a specific time and place to prevent its occurrence at another point in time and space. Suggested means of suppression include: large structures or rods to attract lightning; laser ionization of a discharge channel; radioactive ionization of a path; and rocket-borne wires to induce a discharge.

Newman triggered lightning with rocket-borne wires [Newman et al. 1967]. Although his aim was to bring the lightning discharge to a specific point--in this case a floating laboratory--his approach could be used to divert discharges from a specified area. Newman's technique was to fire a rocket toward a thundercloud from his research vessel. The rocket carried a stainless steel wire (0.2 mm in diameter) from a coil grounded to the ship. In a typical case, once the rocket attained an altitude of about 100 m, a discharge passed between it and the cloud base (1000 m or more above the sea). The discharge then followed the path of the wire to the vessel. Twenty-three attempts during August 1966 resulted in 17 triggered cloud-vessel discharges. Although others have attempted to trigger lightning over land, no successes have been reported.

Application of this technique as a protective measure is limited by the fact that a thunderstorm is a generating mechanism and cannot be discharged like a battery. The time required for the electric field to recover following a discharge is only a few seconds, after which the storm again is ready to discharge.



2. Changing Cloud Development. Lightning is modified by altering the dynamic processes of cloud growth to prevent a cloud from developing to thunderstorm stage. Modification methods suggested are: production of a cirrus layer to shield the surface from incoming solar radiations; "overseeding" with ice-forming nuclei to slow cloud growth; and introduction of hydrophilic materials to arrest cloud development.

Russian scientists have experimented with artificial control of convective cloud development. Reportedly, they introduced 20 to 100 kg of an insoluble aerosol substance (5 to 50  $\mu$  radius) into growing cumulus congestus [Gayvoronsky et al. 1967]. The experimenters reported that immediately after the substance was introduced from above, cloud evolution stopped, tops gradually subsided, and the cloud rapidly acquired a fibrous structure.

Aerosols of substances with different physical and chemical properties, such as cement, alumina, sodium chloride, and chalk, were tested in Soviet laboratories. The Russians report that modification efficiency is about the same for all powders tested and does not vary with temperature. The efficiency of a powder sample depends on the surface properties and the specific weight of the substance, and on the particle size distribution. Hydrophilic powders were found to be the most efficient of the substances tested.

Powder seeding is reported to modify clouds by causing descending air currents [Gayvoronsky et al. 1967]. Modification begins when the seeding agent interacts with cloud droplets to form drops, which continue to grow by coalescence. The falling drops create descending air currents that soon overcome convective motion within the cloud.

In a series of Soviet experiments, powders were introduced into the tops of both airmass and frontal thunderstorms. Radar was used to evaluate results. For 54 of 55 tests performed on clouds of large vertical extent, successful modification was claimed.

3. Altering Electrification Processes. Charge or discharge mechanisms within a thunderstorm are modified. Of the methods proposed to alter electrification processes within a lightning storm, two, chaff seeding and silver iodide seeding, have received considerable emphasis in recent years. These will be discussed in detail.

(a) Chaff Seeding. Weickmann [1963] proposed lightning suppression by chaff seeding and ESSA scientists have since studied the principles in the laboratory and to some extent in the field [Kasemir and Weickmann 1965]. The concept of lightning suppression by chaff seeding is based on the assumption that lightning is initiated by corona discharge from raindrops in a strong electric field. Corona discharge produces an avalanche of ions when an electric field is of sufficient strength and a stepped leader subsequently forms near cloud base. When this leader reaches the ground, it becomes the path for a return stroke. This approach to lightning suppression is based on the hypothesis that chaff seeding will inhibit leader development by limiting the magnitude of the electric field within the cloud.

The field strength at which corona begins on metallized nylon- and copper-chaff of various lengths and thicknesses has been measured in the laboratory [Kasemir and Weickmann 1965]. When an electric field reaches about 300 v/cm (the corona threshold for a fiber 10 cm long and 22  $\mu$  thick), the corona current per fiber is about  $10^{-7}$  amperes.

It has been established that the threshold for corona discharge on a 10 cm-long chaff fiber is about 300 v/cm, a factor of 20 below the threshold field of 6000 v/cm assumed necessary to initiate a lightning discharge. About 2.3 kg of chaff contains  $10^7$  chaff fibers and should produce a 10-amp corona current in a field of 700 v/cm. This current would be adequate to counter the charging current in an average thunderstorm, which is assumed to average about 3 amps.

In actual tests on thunderstorms, Kasemir and Weickmann [1965] reported that corona discharge is generated from chaff fibers in a field greater than 300 v/cm and that corona continues until this field drops below this value. Moreover, they found that stronger fields (on the order of 1 to 3 kv/cm) decay far more rapidly with chaff seeding than without.

ESSA scientists plan additional studies of both charge distribution within a thundercloud and the movement of small ions liberated by corona discharge in a cloud environment. These studies will determine where and in what amounts chaff should be used in actual lightning-suppression tests.

(b) Silver Iodide Seeding. The Forest Service has been investigating the possibility of modifying lightning by seeding with silver iodide for several years. A pilot experiment conducted over forested mountains near Missoula, Montana, through the summers of 1960 and 1961 showed 38% less cloud-to-ground lightning from seeded clouds than from unseeded clouds. A two-tailed test indicated that the probability of this occurring by chance was one in four. In this case, we measured the number of discharges on each test day.

In 1965, we began a new study in which both the occurrence of lightning and the characteristics of individual discharges were measured. The goal was to determine if massive seeding with silver iodide ice-forming nuclei changes the occurrence or characteristics of lightning from mountain thunderstorms. The experiment was carried out over three summer seasons.

Design of the experiment: This experiment was designed to compare electrical and physical events occurring within a circular test area of about 16 km in radius on the seeded and unseeded days between the hours of 1300 to 1900 m.s.t. This unit of time-space was defined as an operational day, the selection of which depended on a regional U.S. Weather Bureau forecast. A set of random numbers established the treatment (seed or no seed). The next operational day received the opposite treatment. Identical observations were made on each operational day.

At the outset, it was declared that simple nonparametric procedures would be used. The Mann-Whitney test [Tate and Clelland 1957] was selected as most suitable for calculating the level of significance for each test. In every case, the resulting probability reported here is for a two-tailed test.

In this report, I refer to all lightning discharges that did not reach the earth as "intracloud" or "cloud" discharges and to those that occurred between cloud and earth as "cloud-to-ground" or "ground" discharges. The term "all lightning" refers to the total number of discharges and includes cloud lightning, ground lightning, and a small percentage of the total that could not be identified (indeterminate). Ground discharges containing continuing-current portions are "hybrid" discharges and all other ground discharges are "discrete."

Both ground-based and airborne-silver iodide generator units were used in the cloud-seeding trials. Three single-engine aircraft were used for each seeding and at least two planes were in the air most of the time. Any thunderstorm or individual large cumulus that appeared in or moved into the test area was seeded by all available aircraft.

All AgI generators used in this experiment produced AgI particles by burning a solution of silver iodide and sodium iodide dissolved in acetone [Fuquay 1967]. The solution was about 2% AgI by weight, plus the amount of NaI required to dissolve the AgI in acetone. Each airborne unit had two combustion chambers. In 1965, each ground-based unit had four chambers, while those used in 1966 and 1967 had two chambers. The output was at  $1 \times 10^{14}$  nuclei/gram of AgI (or  $5 \times 10^{13}$  nuclei/sec effective at  $-20^{\circ}\text{C}$ ) with a flow rate of  $.55 \times 10^4$  ml/hr. During a normal operation, when the three aircraft and the two mobile units were operating simultaneously, as many as 16 AgI generators (combustion chambers) were in use at the same time. Throughout the three-season study, the consumption rate averaged about 2.2 kg of AgI/hr with periodic maxima of 4.2 kg/hr.

Evidence of the effectiveness of seeding to produce glaciation was obtained by a series of in-cloud measurements [MacCready and Takeuchi 1967]. The measurements showed that on several occasions complete glaciation was encountered in seeded clouds even at relatively warm temperatures around  $-7^{\circ}\text{C}$  [MacCready and Baughman 1968]. The concentration of ice particles was estimated to be 100 to 1000/l at  $-7^{\circ}\text{C}$ .

Data limitations: The experiment was designed to compare electrical events occurring within a test area between the hours of 1300 to 1900 m.s.t. on seeded and unseeded operational days. These time and space boundaries were selected because most thunderstorms take place during the afternoon hours and because our recording and cloud-seeding capabilities were limited. Subsequently, we found these boundaries to be unreasonable; they imposed a severe limitation on the use of data for statistical evaluation. About 15,000 lightning discharges were recorded during the three summer seasons, but only 1452 discharges fell within the operational day concept of time and distance.

Further examination of the data clearly showed that only the total lightning activity, of smaller storms (less than 50 discharges) occurred entirely within our original space and time limitations. As a result, larger storms (more than 50 discharges) appeared in the statistical analysis as smaller storms. For example, a large storm 8 July 1965 (1718-1835 hrs) produced 256 discharges, of which only 25 met the distance criterion for the operational day, while a small storm 14 July 1966 (1714-1740 hrs) yielded only 13 discharges, but all were accepted for analysis. Consequently, the operational day concept imposed unrealistic restrictions on the use of available data.

To overcome the limitations imposed by the original design, we tested for seeding effects on the basis of individual storms, thereby eliminating most of the time and space restrictions imposed by the operational day concept. For the individual storm analysis, we considered those storms that produced lightning at any time within about 30 km of the central recording site, when most or all of the lightning came from a storm known to be seeded or unseeded. Storm duration is defined as the time interval from the first to the last lightning discharge ascribed to a particular storm.

Results: The Mann-Whitney Test was used to test all data reported here for the efficacy of cloud seeding. In every case, the given probability is for a two-tailed test. In Table 1, the test for differences in the occurrence of lightning on operational days clearly shows that these results could have occurred by chance ( $\alpha = 0.617$ ). I feel that use of operational day data only does not permit a correct evaluation of the cloud-seeding trials because of the limitations discussed in the previous section. However, the operational day unit was prescribed by the original design of the experiment; so I have reported the results obtained.

Table 1.--Lightning occurrence during 28 operational day units

Type	Number		Means		Significance level*
	No seed	Seed	No seed	Seed	
Cloud-to-ground	156	170	11.1	12.1	0.920
Intracloud	501	531	35.8	37.9	.555
All lightning**	674	765	48.1	54.6	.617

\* Two-tail Mann-Whitney tests.

\*\* Includes indeterminate discharges.

Realizing that the time and space criteria of the original design were creating problems, we based further tests for seeding effects on individual storms. In effect, we changed the time and space restrictions and removed from the analyses all days on which no lightning occurred.

The amount of lightning recorded from seeded and unseeded individual storms and results of the statistical tests are given in Table 2. These results are quite different from those shown in Table 1. These analyses differ because we changed our time and space boundaries and also because we excluded those days on which no lightning occurred from the individual storm analysis. The effect of these changes on the analysis is still being studied. It is obvious that considerably less lightning was produced by seeded storms, but these results should be treated with caution because subjectivity may have influenced our determination of storm duration. It was relatively easy to identify individual storms, but not always possible to

determine the exact time that lightning activity began or ended. As is shown in Table 3, the duration of lightning activity of seeded storms was significantly less than that of unseeded storms ( $\alpha = 0.086$ ). Additional studies of the location, movement, and radar echo duration of both seeded and unseeded individual storms disclosed no appreciable differences in storm location or movement.

Table 2.--Lightning occurrence during 26 individual storm units

Type	Number		Means		Significance level*
	No seed	Seed	No seed	Seed	
Cloud-to-ground	792	231	56.6	19.2	0.174
Intracloud	2367	1021	169.1	85.1	.085
All lightning**	3238	1286	231.0	107.0	.099

\* Two-tail Mann-Whitney test.

\*\* Includes indeterminate discharges.

Table 3.--Duration of lightning activity during 26 individual storms

	Means		Significance level*
	No seed	Seed	
Duration of lightning activity (min)	101	64.2	0.086

\* Two-tail Mann-Whitney test.

Next, we compared the rates at which lightning discharges occurred in seeded and unseeded individual storms. The outcome of a test for differences in the maximum flash rate for 5- and 15-minute intervals for 26 individual storms is given in Table 4. In light of the significance level for cloud-to-ground lightning for 3-minute intervals ( $\alpha = 0.197$ ) and 15-minute intervals ( $\alpha = 0.156$ ), these results only suggest that the flash rate is reduced by seeding with AgI ice-forming nuclei. Further tests are being made to determine whether or not seeding alters flash characteristics, such as duration, number of return strokes, and the interval between return strokes.

I believe that results of experiments to date (Tables 1-4), support the hypothesis that lightning occurrence from mountain thunderstorms can be altered by cloud seeding. We recognize that our results are not conclusive and that further experimental work will be needed. Moreover, it should be noted that the principal statistical results presented are based on an analysis different from that prescribed at the beginning of this study. The information on lightning characteristics and occurrence, along with the valuable test experience should enable us to design a new and, hopefully, more definitive experiment.

Table 4.--Maximum lightning intensity for 5- and 15-minute periods for 26 seeded and unseeded individual storms

	Means		Significance level*
	No seed	Seed	
Maximum amount lightning in 5-minute period			
Cloud-to-ground	8.8	5.0	0.197
Cloud-to-ground	17.4	16.3	.596
All lightning**	23.2	18.8	.358
Maximum amount lightning in 15-minute period			
Cloud-to-ground	17.7	9.1	.156
Cloud-to-ground	43.9	33.4	.204
All lightning**	53.5	42.4	.327

\* Two-tail rank-sum test.

\*\* Includes indeterminate discharges.

Now what is the outlook for lightning suppression? Some advances have been made through lightning and cloud physics research. However, no results to date are conclusive. Several remaining questions on cloud electrification and lightning physics must be answered before realistic programs of lightning suppression can be devised. These answers should come from current and planned research. When they do, the feasibility of lightning suppression and control can be determined.

#### REFERENCES

- Fuquay, Donald M.  
 1967. Weather modification and forest fires. Pp. 309-326, in "Ground Level Climatology," Amer. Assoc. Advance. Sci., Washington, D.C.
- Gayvoronsky, I. I., Cr. A. Seregin, and L. P. Zatsepina.  
 1967. Experiments on thunderstorm modification. General Assembly IOJG, LAMAP-V7: 238.
- Kasemir, Heinz W., and Helmut K. Weickmann.  
 1965. Modification of the electric field of thunderstorms. Int. Conf. on Cloud Phys. Proc., May 24-June 1, 1965. Tokyo and Sapporo.
- MacCready, P. B., Jr., and R. G. Baughman.  
 1968. The glaciation of an AgI-seeded cumulus cloud. J. Appl. Meteorol., 7(1): 132-135.
- MacCready, Paul B., Jr., and Donald M. Takeuchi.  
 1967. Aircraft probing of natural and seeded clouds for Project Skyfire. Meteorology Research, Inc., MRI67-FR-49, 42 pp.
- Newman, M. M., J. R. Stahmann, J. D. Robb, E. A. Lewis, S. G. Martin, and S. V. Zinn.  
 1967. Triggered lightning strokes at very close range. J. Geophys. Res., 72(18): 4761-4764.
- Tate, Merle W., and Richard C. Clelland.  
 1957. Nonparametric and shortcut statistics. Interstate Printers and Publishers, Danville, Ill., 171 pp.
- Weickmann, Helmut K.  
 1963. A realistic appraisal of weather control. J. Appl. Math. Phys. (ZAMP), 14(Fasc. 5): 528-543.

## HAIL SUPPRESSION IN THE SEVENTIES

Guy G. Goyer  
National Center for Atmospheric Research\*  
Boulder, Colorado

### I. Introduction

In the last two decades a considerable effort has been extended towards the suppression of hail in several countries of the world. There are three basic reasons for this focusing of effort in this area of weather modification. The first one is the economic benefits that can result from an operational hail suppression system. In the United States alone the damage to crop and property caused by hail amounts to two to three hundred million dollars a year. The second reason is that, because the hailstorm is, in most cases, an isolated convective system, it appears more amenable to field experimentation. Finally, the third and most important reason is that the early discovery of Schaefer that clouds can be glaciated with artificial freezing nuclei appears to several experimentalists to provide the trigger mechanism necessary to modify hailstorms.

Consequently, over the last 10 to 15 years several attempts at testing this concept for the suppression of hail have been made in France (Dessens, 1967), Argentina (Grandoso and Iribarne, 1961), Italy, Kenya (Sansom, 1966) (Henderson, 1968), Russia (Sulakvelidze, 1968), Canada, Switzerland (Schmid, 1967), and the United States (Schleusener). In all of these efforts the basic physical concept has been the conversion of the supercooled liquid water to ice crystals by seeding with silver iodide, lead iodide, or solid carbon dioxide. The hypothesis is that the creation of a larger number of hail embryos through seeding should lead to a larger number of hailstones of smaller diameter. Although no physical model of the hailstorm had been developed at that time to support that idea, large scale field programs were set up to verify that simple concept.

In most cases the instrumentation was restricted to seeding instrumentation consisting mostly of ground or airborne burners, or anti-hail rockets of one kind or another. Observational equipment such as radar was lacking in France, Argentina, Italy, Kenya, Switzerland, and Canada. Moreover, no ground network for evaluating precipitation was used in all of these projects nor in the Soviet project. Only the United States project in South Dakota combined seeding operations with radar and ground observations.

TABLE I  
HAIL SUPPRESSION AROUND THE WORLD

<u>Location</u>	<u>Method</u>	<u>Area, mi<sup>2</sup></u>	<u>% Decrease</u>	<u>S./acre</u>	<u>Reference</u>
Russia	Shells	3850	80	0.07	Sulakvelidze (1968)
France	Ground burners	23,000	50	0.02	Dessens (1967)
Kenya	Explosive rockets	1.8 (15)	50	0.41	Sansom (1966)
	Airborne pyrotechnics Ground pyrotechnics	400	55	0.14	
Canada	Ground burners	3700	65	--	
	Airborne burners				
	Airborne pyrotechnics				
USA Bartan Slope	Airborne burners	7000	28	--	Bagen & Burchbaker (1966)
	Ground burners				
Perkin County	Airborne burners	1400	96	--	Koscielski (1967)
	Airborne pyrotechnics				
Eapid Project	Airborne burners	700	51	--	Schleusener & al. (1969)
	Airborne pyrotechnics				
	Ground burners				

\*The National Center for Atmospheric Research is sponsored by the National Science Foundation.

Table I shows the results of these projects. It shows the method used, the area protected, the percent decrease in hail damage and the cost of protection per acre. The results claimed in suppressing hail are certainly impressive. However I would like to point out that all of the foreign results are based on crop insurance data. As is well known, crop damage is a very unsatisfactory criteria for evaluating the effects of hail suppression attempts. The seasonal variation of the crop, the low coverage of insurance data, the associated crop damage due to wind and rain are all factors which reduce the accuracy of evaluating hailfall intensity from insurance data. Dr. P. W. Summers (1966) of the Alberta Hail Studies recently published the results of a study of hail insurance claims as a means of evaluation of the Canadian hail suppression experiments. His conclusions are the following:

There appears to have been substantial reduction in the loss to risk ratio in the hail suppression area during the last ten years. However, this could quite easily be the results of chance, natural fluctuations in storm activity. This fact, together with the unexplained reductions observed elsewhere, means that no conclusions can be drawn regarding the effectiveness of commercial hail suppression program operated by the Alberta Weather Modification Cooperative. This does not imply there is not a real suppression effect: but if such an effect does exist, it cannot be accurately detected by a study of yearly mean loss to risk ratios.

The article concludes that some alternative methods of evaluation must be found for both the immediate purpose of evaluating present commercial hail suppression programs and, even more importantly, as a necessary prerequisite to the sound scientific design of any research experimentation on hail clouds.

Unfortunately, at the present time, after several years of field experimentation, we are faced with the same problems we faced for the case of rain augmentation. There is considerable evidence of success resulting from all of these projects. However, none of that evidence is as yet statistically satisfactory to the scientific community. Because of poor experimental design, lack of adequate instrumentation, or lack of randomization procedures, these results are intriguing but, unfortunately, lack the validation of sound statistical methods. On the other hand, the recent results obtained by the South Dakota School of Mines and Technology (Schleusener et al., 1969) show that a proper experimental design can lead to meaningful numbers to determine the effect of cloud seeding on hail intensity. But this is not enough. A totally convincing hail suppression experiment will only result from the combination of a realistic theoretical model of the hailstorm, a sound modification concept, and accurate real time measurements of the storm, its environment, and its precipitation.

## II. Future Hail Suppression Concepts

It is obvious, from reading the hail suppression literature of the last decade, that the major weakness of our previous efforts has been the neglect of incorporating the theoretician and the statistician into the design of field programs. Up to now it appears that the cloud modeler and the cloud seeder have been kept completely apart. However, with the recent rapid progress in the area of cumulus cloud modeling, it is comforting to see that this marriage between the theoretician and the experimentalist is gaining favor. The present trend is to use computer models of cumulus clouds not only for forecasting but also for evaluating modification attempts. Such techniques pioneered by the Navy-ESSA Stormfury Project on cumuli cloud (Simpson et al., 1966), are now being used in the Flagstaff Project with Penn State (Davis et al., 1968) (Weinstein, 1969), the South Dakota Project with E. G. and G. (Davis et al., 1969), and finally this year in the Joint Hail Research Project of CSU, ESSA, and NCAR in Northeastern Colorado. The computer models are used to predict cloud tops, maximum updraft velocity, hail size, and even radar reflectivity for seeded and nonseeded clouds. The field observations are essential in testing the present models and, most importantly, in improving the model to better describe the natural phenomenon. This two-pronged attack is, in my opinion, the most important development which will have its major impact on hail suppression experimentation in the 70s and which should lead to the most rapid development of an efficient hail suppression system based on a full understanding of the hail storm. Once this optimized model is developed, based on actual field measurements, other suppression concepts will then be amenable to testing on the computer, a much more efficient and much cheaper method to test concepts.

Up to now the conversion of supercooled liquid water to ice crystals has been the basis of all hail suppression experiments. This concept can be tested on the computer for its



effect on the buoyancy of the cloud. However, the concept cannot be tested for its effect on precipitation. With the advent of larger computers it should be possible within the not too distant future to compute the growth of precipitation particles rather than to use parametrization procedures to feed into the present models.

Several other concepts for modification have been suggested but have not been tested in the field yet. The Soviets have proposed seeding with large hygroscopic nuclei in order to rob the hailstorm of large concentrations of water in the supercooled region of the cloud. In this manner the concentration of supercooled liquid water would be reduced by provoking the precipitation of a large mass of water before it reaches the supercooled region of the cloud. This technique is just being initiated in the Soviet Union, and the concept can be tested on the computer at the present time.

Other concepts applying to a field of convective clouds have also been suggested. It has been proposed to disturb the windfield around a potential thunderstorm by seeding several other smaller clouds around it to prevent its development to a mature thunderstorm. Schaefer proposed the disturbance of convection through the creation of a cirrus cloud cover by seeding over a large area. These concepts can only be tested by computer techniques when adequate models and large enough computers are developed to handle a field of cumuli clouds over a rather large area. It is my contention that a large scale effort should be propounded in that area to provide within the next decade the possibility of testing new hail suppression concepts by computer techniques before attempting to test them in large field experiments.

### III. Future Instrumentation

As we mentioned before, the development of computer models relies very heavily on the collection of accurate data in the field. The full understanding of the hailstorm requires the total description of the cloud, its environment, and its precipitation. Do we now have the instrumentation for this task?

The instrumentation to describe the environment of a cloud is already available or in intense development at the present time. The windfield around a cloud can be adequately described by such techniques as used by Weickmann (1969), Auer et al. (1969), Sinclair (1969), Garrahan et al. (1969) and Cooper et al. (1969) for updraft mapping below cloud and for measuring wind components around the cloud and at cloud top. High level winds can be well described by an adequate number of rawinsonde stations, and ground meteorological observations can also be gathered by existing meteorological stations. To supplement the current instrumentation, interesting developments are in the offing. The network of three 3 cm doppler radars proposed and being developed by L'Hermitte (1969) at ESSA will be an important addition for the description almost in real time of the three wind components around cloud base. The new electromagnetic signal detection system proposed by DRI to track simultaneously a large number of balloons is an extremely promising method to describe not only the cloud's environment but also the cloud internal structure. These systems will become available in the 70s and should provide the data critically needed by the computer modelers to improve their models. The instrumentation to study the atmospheric nuclei and their role in the development of precipitation is already available and already yielding important data for the full understanding of the hailstorm (Rosinski and Kerrigan, 1969).

The description of the storm structure is one of the most challenging requirement in hail suppression research. The accurate description of the radar reflectivity profile is most urgent. Narrow beam quantitative weather radars of greater precision will soon be available for this task. An advanced dual wavelength radar has been proposed by NCAR and is under development (Fisher, 1969). A 10 cm doppler radar with polarization measurement capability is now being assembled by Atlas at the University of Chicago. But the most interesting development in this area is the addition of a field computer to the radars to present the radar data in real time. This is a critical requirement in the operation of a hail suppression test. The systems developed by DRI and by South Dakota School of Mines are the most promising tools to date in these areas. I am convinced that in the 70s such real time systems will play a very important role in the evaluation of seeding experiments for hail suppression.

The description of the vertical velocity profile and of the liquid water content profile are still impossible at the present time owing to lack of proper instrumentation. However, promising developments are appearing in this area also. Battan (1963) demonstrated the usefulness of a vertically pointing doppler radar for the description of the updraft profile, and the detection of hail (Battan, 1968). A manned armored aircraft for penetrating the

core of hailstorms has been developed by South Dakota School of Mines in cooperation with MRI and is scheduled to be tested operationally this summer. With proper instrumentation this aircraft will hopefully be capable of measuring vertical velocity profiles and liquid water content profiles. In addition, a feasibility study is now underway at CSU to establish the possibility of using a drone aircraft for the same purpose. The dropsonde system initiated by Squires and developed by Bushnell (1968) at NCAR shows, also, promise of accurately measuring updraft velocity profiles in the core of mature thunderstorms. Finally, the 2.75" rocket, used in the military, is currently being scrutinized as a platform to penetrate the core of hailstorms to measure these variables also; it is my expectation that within this decade one or more of these proposed systems will be fully developed to gather the data necessary for the testing and the improvement of the computer models. However, considerable expenditure and effort will have to be channeled to the development of a cloud liquid water content meter capable of handling the large concentrations of supercooled water in mature hailstorms. Several new techniques have been proposed or are in development at NCAR, such as the photographic method by Cannon (1968), the electrostatic method by Winn (1968), the optical electronic method by Knollenberg (1969), the laser cavity method by Knollenberg and Schuster, and the centrifuge method developed by Brown. Continuous progress in the centrifuge method developed by Brown. Continuous progress in the replication of cloud particles has also been reported by the U.S. Naval Research Laboratory (Averitt and Ruskin, 1966). Finally, the exploratory work of ESSA with a microwave radiometer appears promising (Decker and Dutton, 1968) (Decker and Dutton, 1969).

Efficient cloud seeding systems have been developed over the several past years that now permit the tailoring of the seeding rate to the situation at hand. The high output burner generators have been used apparently rather effectively in an airborne system by MRI (Davis et al., 1968) in Flagstaff, by the Department of Agriculture at Missoula, (McCreedy and Baughtman, 1968), by South Dakota School of Mines and Technology (Koscielski and Dennis, 1968) and by CSIRO in Australia (Bethwaite et al., 1966).

Pyrotechnic generators of high efficiency have been developed by the Navy and are now commercially available from several private firms. These have been used in several systems. ESSA has developed the capability to drop them from the top of cumuli cloud, and several universities and private firms have designed and utilized airborne racks to disperse at cloud base the smokes generated by pyrotechnics. By the use of these methods, the rate of seeding can be tailored to the area and intensity of the updraft at cloud base. As shown by Schleusener (1968), we now have the capability of seeding at rates between a few grams to three or four thousand grams per hour.

The apparent success of the Soviet program (Sulakvelidze, 1968) stirred the interest of the U.S. scientists in seeding techniques which would insure the accuracy of placement of the seeding agent into a well defined volume of the cloud. Considerable progress has been made over the last two years by Sinclair (1968) at CSU in the development of a small frangible airborne rocket for cloud seeding. This rocket can carry a payload of a hundred to two hundred grams of silver or lead iodide and be shot to approximately 8 or 9 miles inside of the cloud. The detonation of the head disperses the nucleating agent. This system might be tested this summer within the Joint Hail Research Project. In addition, there has been considerable interest from many institutions such as E. G. and G., CSU, and NCAR in the adaptation of the military 2.75" rocket for cloud seeding and in-cloud measurement purposes. This is an obvious area where the Air Force could contribute immensely to the development of a consumable or frangible airborne rocket for cloud seeding or for cloud measurement purposes. I then foresee that in the next two years we will have airborne rockets cloud seeding systems with which to test the Russian contention of the importance of applying the seeding agent very accurately in space and in time. Consequently, within a few years we will have at our disposal a real arsenal of seeding systems which will permit the accurate delivery in space and time of seeding agents of any type at an accurately controllable rate. As a result, it will then be possible to tailor accurately the seeding procedure and rate to the volume, intensity, and rate of growth of the systems to be studied.

To complete the system of observation in a well-conceived hail suppression experiment, a suitable ground network for evaluating the hailfall and the rainfall is absolutely necessary. This is an area where engineering development is required to provide, in a very few years, a cheap, portable, automatic precipitation sensor capable of transmitting in real time to a central location the time of onset of rain and hail, the rainfall rate and the hailfall rate, and the duration of each event over a large network. The Illinois State Water Survey has done wonders with the current instrumentation in correlating the hailswath to radar data

(Changnon and Stout, 1969). The type of network established in Illinois is certainly an example of what will be required for the evaluation of a hail suppression experiment. However, an automated transmitting station would certainly provide more accurate data at a cheaper cost. The use of volunteer observers and of telephone surveys in real time, as initiated in Alberta and very effectively used this summer in northeastern Colorado, is one cheap but not totally satisfactory way of solving that problem.

The evaluation of the hailfall at the ground still requires a large number of ground teams chasing and sampling the hail to determine such things as number concentration, size distribution of the hail, hardness, liquid water content, and so on. From that data the percent coverage can be calculated. Last summer Dr. Weickmann of ESSA in collaboration with H.R.B. Singer showed the usefulness of airborne infrared radiometry to measure the coverage of hailstones at the ground and to map the hailswath (Weickmann, 1969). Again this summer both ESSA and NCAR are testing similar techniques. With such techniques it may be possible to reduce the number of ground stations necessary to fully evaluate the intensity of hailstorms. In the final analysis, the success of any hail suppression experiment will have to be judged on the basis of the evaluation of hail at the ground. This is an area which will require in the very near future considerable effort and expenditure to develop the required instrumentation and data gathering and processing systems necessary to provide an accurate picture of the precipitation pattern almost in real time.

#### IV. THE PROMISE OF THE 1970'S

From this brief description of current research and of proposed development, it appears very clearly that within one or two years we will have available the several components critical in the design and implementation of a comprehensive hail suppression experiment. As mentioned in the Suomi Report (Suomi et al., 1968) and in the recent Rand Report (1969) on weather modification, most of our previous research in hail suppression in the United States has been subcritical. No one has been able, up to now, to assemble the critical elements to accurately test hail suppression concepts and operations. However, these previous projects have served and will continue to serve in the next decade a very essential role in developing the elements which are critical for future progress in that area. What is necessary and essential at the present time is to mount a large enough effort capable of assembling in a single, well-designed experiment the capabilities developed within groups already experienced in hail research. This is the hope in NECHE, the Northeastern Colorado Hail Experiment (1969). At the request of the National Science Foundation, NCAR together with a Planning Committee has prepared a plan for a large scale, long duration hail suppression experiment in northeastern Colorado. This plan envisions an impressive effort in the years 1971-1975 and has been enthusiastically endorsed by ICAS. The goals of NECHE are to advance the basic understanding of the hailstorm in a study oriented towards the suppression of hail. The approach of NECHE will be to establish and maintain vigorously the communication links between the theoreticians, the dynamicists, the cloud physicists, and the field experimenters towards the single goal of improving the theoretical model on the basis of field observations, and designing a suppression system on the basis of the theoretical model. Continuous feedback between all systems is considered the critical element of such a project.

Figure 1 shows a sketch of the optimum system proposed by NECHE for hail suppression research. It comprises elements which are or will be available within the next few years. It also depicts the large scope of the project which will require the full support and the active participation of several federal agencies, universities, and private firms.

It is my conviction that the philosophy and the experimental design of NECHE are the most promising toward the most rapid progress in hail suppression research. However, NECHE will not attain its goal in complete isolation but will require the full cooperation and the full support of the hail scientists in other projects in this country.

I am convinced that we are at a threshold of knowledge and technology which will lead in the next decade to a very significant breakthrough in hail suppression. The work ahead is challenging. But we have the brainpower, we have the manpower and we have the components of the optimum system. We have all that. But we do not yet have adequate funding. If NECHE and the several other projects in the U.S.A. are funded at the necessary level for optimum return, and if we are willing to work diligently and effectively and to listen to the answers

nature supplies to our questions, I am personally convinced that we will have an operational hail suppression system by the end of the 1970s.

**SCHEMATIC OF NORTHEAST COLORADO HAIL EXPERIMENT**

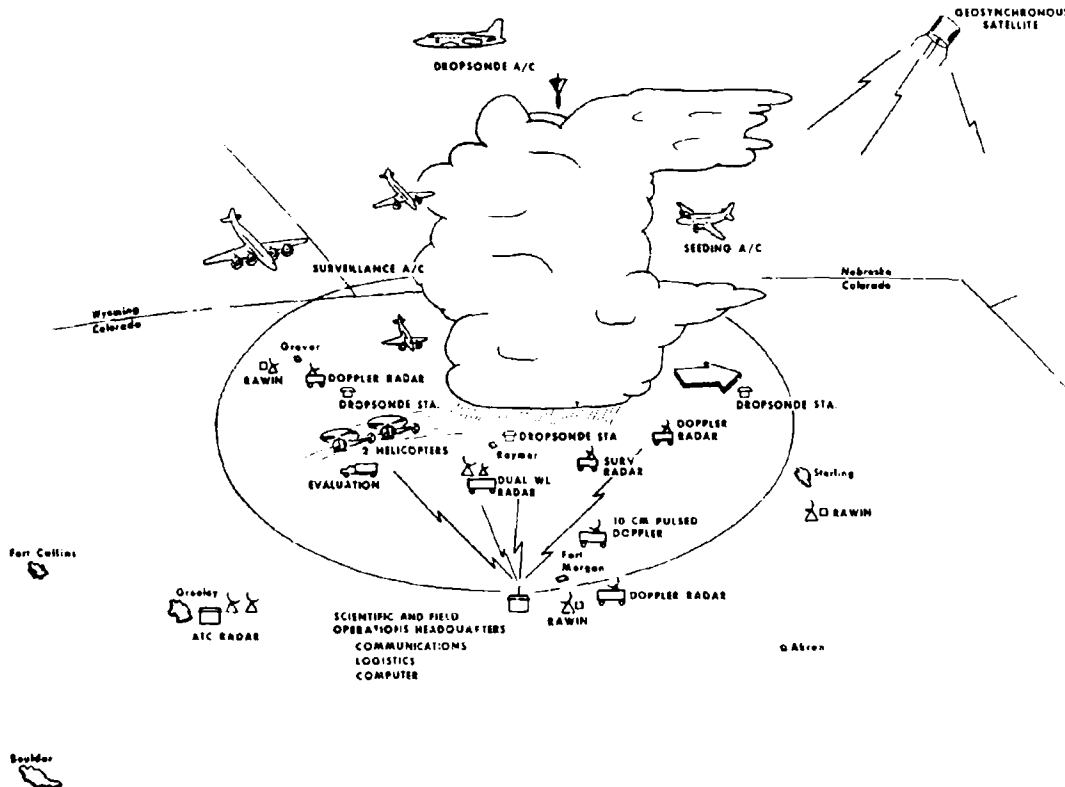

**FIGURE I**

**REFERENCES**

Auer, Jr., A. H., D. L. Veal, and J. D. Marwitz, 1969: Updraft Deterioration Below Cloud Base. Preprints of Papers Presented at the Sixth Conference on Severe Local Storms, Chicago, Illinois, 8-10 April, 16-19.

Averitt, J. M., and R. E. Ruskin, 1966: Cloud Particle Replication in Stormfury Tropical Cumulus. Project Stormfury Report No. 5-65, U.S. Naval Research Laboratory, Washington, D. C., 19 pp, May 1.

Battan, L. J., A. R. Kassander, Jr., and J. B. Theiss, 1963: Observations of Convective Clouds by Means of Pulsed Doppler Radar. Sci. Report No. 20, Institute of Atmospheric Physics, The University of Arizona, Tucson, Arizona, January, 21 pp.

- Battan, L. J., and J. R. Theisz, 1968: Detection of Hail by Means of Doppler Radar. Sci. Report No. 74, Institute of Atmospheric Physics, the University of Arizona, Tucson, Arizona, May, 18 pp.
- Bethwaite, F. D., E. J. Smith, J. A. Warburton and K. J. Heffernan, 1966: Effects of Seeding Isolated Cumulus Clouds with Silver Iodide. J. Appl. Meteor. 5, 513-520.
- Bushnell, R. H., 1968: Dropsondes -- Studies of Thunderstorms, Facilities for Atmospheric Research, NCAR, No. 6, Sept., 2-6.
- Cannon, T. W., 1968: Yellowstone Field Expedition VIII Report. Interim Report, Publ. No. 68, State University of New York, Albany, 45-52.
- Changnon, Jr., S. A., and G. E. Stout, 1969: A Mesoscale Analysis of Hail and Heavy Rain on 15 May 1968. Preprints of Papers Presented at the Sixth Conference on Severe Local Storms, Chicago, Illinois, 8-10 April, 303-309.
- Cooper, L. W., D. C. Hall and D. R. Booker, 1969: Report on Hail Models Project. Vol. IV. "Updraft Mapping and Balloon-Transponder Tracking." Report No. 69-1. IAS South Dakota School of Mines and Technology, Rapid City, South Dakota.
- Davis, L. G., J. I. Kelley, A. Weinstein, and H. N. cholson, 1968: Weather Modification Experiments in Arizona. Report No. 12A and Final Report NSF-GA-777, November.
- Davis, L., P. Willis, and O. Rhea, 1969: Report on Hailstorm Models Project, Vol. III. "Observational and Numerical Studies of Updraft Structure." Report 69-1, IAS, South Dakota School of Mines and Technology, Rapid City, South Dakota, February, 59 pp.
- Decker, M. T., and E. J. Dutton, 1968: Radiometric Observation of Thunderstorm Cells. Proc. of the 5th Symposium on Remote Sensing of Environment, Ann Arbor, Michigan, Apr. 16-19, 617-29.
- Decker, M. T., and E. J. Dutton, 1969: Radiometric Observations of Liquid Water in Thunderstorm Cells. Preprints of Papers Presented at the Sixth Conference on Severe Local Storms, Chicago, Illinois, 8-10 April, 163-164.
- Dessens, H., et al., 1967: Association D'Etudes des Moyens de Luttés contre les Fieux Atmosphériques. No. 15, Toulouse, France, 78 pp.
- Fisher, R. E., and R. H. Bushnell, 1969: Some Dual Wavelength Studies of a Hailstorm in Northeastern Colorado. Preprints of Papers Presented at the Sixth Conference on Severe Local Storms, Chicago, Illinois, 8-10 April, 159-162.
- Fossat, M., 1966: La Lutte contre la Grêle: Expériences Effectuées dans les Départements du Lot-et-Garonne et du Tran-et-Garonne. O.R.I.D.E.C.A. Association Climatologique de la Moyenne Garonne, Agen, France, 100 pp.
- Garrahan, B. M., B. J. Carley and T. J. Henderson, 1969: Areal Inflow Mapping and Related Time-lapse Photography. Atmospheric Inc. Report 69-1, IAS, South Dakota School of Mines and Technology, Rapid City, South Dakota, February, 20 pp.
- Grandoso, H. H., and J. V. Iribarne, 1961: The Experiment on Hail Prevention in Mendoza, Argentina. Proc. Int. Conference on Cloud Physics, Canberra, Australia, 74-76.
- Hagen, L. J., and A. F. Butchbaker, 1967: Climatology of Hailstorms and Evaluation of Cloud Seeding for Hail Suppression in Southwestern North Dakota. Proc. Fifth Conf. on Severe Local Storms, St. Louis, Mo., 336-346.
- Henderson, T. J., 1968: The Kericho-Nandi Hills Hail Suppression Program - 1967-68 Season. Final Report to the Tea Growers of Kenya, Atmospheric Incorporated, 4981 E. Dakota, Fresno, California.
- Hitschfeld, W., and R. H. Douglas, 1961. A Theory of Hail Growth Based on Radar and Surface Studies of Alberta Hailstorms. Proc. 9th Weather Radar Conf., AMS, Boston, Mass., 153-158.

- Knollenberg, R. G., 1968: An Optical Electrical Particle Size Discriminator. Facilities for Atmospheric Research, NCAR, Boulder, Colorado, No. 6, Sept., 17.
- Koscielski, A., 1967: Hail Occurrences in Perkins County, South Dakota. Report 67-6, Institute of Atmospheric Sciences, South Dakota School of Mines and Technology, Rapid City, South Dakota, 10.
- Koscielski, A., and A. S. Dennis, 1968: A Randomized Seeding Experiment in South Dakota. Proc. First Conf. on Weather Modification, State University of New York, Albany, New York, AMD, May, 47-54.
- L'Hermitte, R. M., 1969: Doppler Radar Observation of a Convective Storm. Preprints of Papers Presented at the Sixth Conference on Severe Local Storms, Chicago, Illinois, 8-10 April, 139-145.
- McCready, Jr., P. B., and R. G. Baughman, 1968: Glaciation of an AgI Seeded Cumulus Cloud. J. Appl. Meteor., 7, 132-135.
- National Academy of Science-National Research Council, 1966: Weather and Climate Modification - Problems and Prospects. Publication 1350, see pp. 37-40 and Section I, part B.
- NECHE, 1969: The Northeastern Colorado Hail Experiment. National Center for Atmospheric Research, Boulder, Colorado, March, 44 pp.
- Rand Report, 1969: Weather-modification Progress and the Need for Interactive Research, Staff, Weather Modification Project, Rand Corporation, Santa Monica, California, Bull. AMS, 50, #4, April, 216-46.
- Rosinski, J. and T. Kerrigan, 1969: The Role of Aerosol Particles in the Formation of Raindrops and Hailstones in Severe Thunderstorms. J. Atm. Sci., July.
- Sansom, H. W., 1966: The Use of Explosive Rockets to Suppress Hail in Kenya. Weather, 21, #3, 86-91.
- Simpson, J., R. H. Simpson, J. R. Stinson and J. W. Kidd, 1966: Stormfury Cumulus Experiments: Preliminary Results - 1965. J.A.M., 5, 521-525.
- Schleusener, R. A., 1968: Hailfall Damage Suppression by Cloud Seeding. A REview of the Evidence. J. Appl. Meteor., 7, 1004-1011.
- Schleusener, R. A., A. Koscielski and M. R. Schock, 1969: Recent Data on Hail Suppression by Cloud Seeding in South Dakota. Preprints of Papers Presented at the Sixth Conference on Severe Local Storms, Chicago, Illinois, 8-10 April, 338-339.
- Schleusener, R. A., et al., 1966: Project Hailswath: Final Report (3 volumes). Institute of Atmospheric Sciences, South Dakota School of Mines and Technology, Rapid City, South Dakota.
- Schmid, P., 1967: On Grossversuch III, a Randomized Hail Suppression Experiment in Switzerland. Proc. Fifth Berkeley Symposium on Math. Statistics Probability, University of California Press, 141-159.
- Sinclair, P. C., 1968: Joint Hail Suppression Research Program in Northeastern Colorado. Annual Report, Department of Atm. Science, Colorado State University, Fort Collins, Colorado, 12 pp.
- Sinclair, P. C., 1969: Vertical Motion and Temperature Structure of Severe Convective Storms. Preprints of Papers Presented at the Sixth Conference on Severe Local Storms, Chicago, Illinois, 8-10 April, 346-50.
- Soulages et al., 1965: Recherches sur la Prevention de la Grêle. G.I.E.F.A., Valence (Drôme), France. Rapport Technique No. 7 bis, 108 pp.
- Sulakvelidze, G. K., 1967: Findings of the Caucasus Anti-Hail Expedition (1965). Translation. National Science Foundation, 59 pp.

- Sulakvelidze, G. K., 1967: Showers and Hail. Gidrometeoizdat, Leningrad, pp. 412.
- Sulakvelidze, G. K., 1968: On the Principles of Hail Control Method Applying in the USSR. Proc. Intl. Conf. on Cloud Physics, Toronto, Canada, 796-903.
- Sulakvelidze, G. K., et al., 1967: Formation of Precipitation and Modification of Hail Processes. Translation. National Science Foundation, 208 pp.
- Summers, P. W., 1966: Note on the Use of Hail Insurance Data for the Evaluation of Hail Suppression Techniques. Report #52, Research Council of Alberta, Edmonton, Canada.
- Suomi, V. E., et al., 1968: Proposed Plan for a National Hail Suppression Research Program. National Science Foundation, March.
- Weickmann, H. K., 1969: ESSA - 1968 - Colorado Hail Research. Preprints of Papers Presented at the Sixth Conference on Severe Local Storms, Chicago, Illinois, 8-10 April, 314-319.
- Weinstein, A. I., 1969: A Numerical Model of Cumulus Dynamics and Microphysics. Report No. 13, NSF-GA-3956, January.
- Winn, W. P., 1968: An Electrostatic Theory for Instruments which Measure the Radii of Water Drops by Detecting of Change in Capacity Due to the Presence of a Drop. J.A.M., 7, 929-937.

## PRECIPITATION AUGMENTATION

Patrick Squires  
Laboratory of Atmospheric Physics, Desert Research Institute,  
University of Nevada

### I. Introduction

Over twenty years ago, the initial experiments in cloud seeding gave rise to the hope of developing a new and useful technology for increasing precipitation. Progress to this end has been disappointingly slow until quite recently.

It is always difficult to guess how deep a physical understanding is needed to generate practically useful results. The twenty-year effort has largely been used in a gamble that the most elementary comprehension would suffice. Although it did not succeed, the gamble was reasonable at the time, but not perhaps for quite so long. A much smaller effort has in the meantime added slowly to physical understanding of some of the processes by which precipitation is formed, and there are signs that significant steps forward in technology may be possible.

### II. The Central Problem

Observation shows that the central problem of precipitation formation is: how is the water substance in some  $10^2$  to  $10^3$  cloud drops ( $d \approx 10\mu$ ) brought together to form a particle large enough to fall to the surface without evaporating ( $d = 1000\mu$ )? The majority of clouds contribute nothing to the return flux of water from the atmosphere to the surface (which must on the average balance evaporation) because they evaporate before precipitation particles are produced, as a result of turbulent mixing with the much drier air around them. In the consideration of the mechanism which form precipitation particles, therefore, time is of the essence. Observation indicates that clouds can form and release precipitation in periods of order 1000 seconds, and elementary considerations indicate that, once particles of  $d \approx 100\mu$  are formed, they grow quite rapidly to  $d \approx 1000\mu$  by sweeping up the cloud drops in their path. The "resistance" to precipitation formation is primarily in growth from  $d \approx 10\mu$  to  $d \approx 100\mu$ .

### III. Warm Rain

Three physical ideas have contributed to our understanding of rain formed by the coalescence of drops in clouds devoid of ice, that is "warm rain". Such rain is found to be common in maritime clouds, but much rarer over the continents.

(a) Early theoretical estimates for the time required for raindrop formation ranged up to some hours, i.e., several times longer than indicated by observation. The stochastic theory of Telford (1955) removed this anomaly. The essence of this theory is that coalescence is a random event, and not a continuous process as had been assumed earlier. Any slightly larger drop, which is growing by sweeping up cloud drops in its path, may have either good or bad "luck", since the cloud drops are randomly distributed. At the worst, it could fall right through the cloud without a collision; a very "lucky" drop could have below it a sequence of smaller drops arranged like the beads on a necklace, practically in contact with each other. A drop as lucky as this would grow into a raindrop in seconds.

Telford posed and answered the question "how lucky is the luckiest drop in a million?" Since it will outgrow all others, it will fall out of the base as a raindrop, containing on the average the water substance originally distributed in  $10^6$  cloud drops, and the time required is in consonance with observation.

(b) Woodcock (1953) has pointed out the role of giant sea salt nuclei ( $d \approx 1$  to  $10\mu$ ) in forming the embryos of raindrops. These giant nuclei, of order  $10^6$  times the mass of the nuclei on which the general population of drops form, generate quite large drops in the humid air even while it is still below cloud base, and, therefore, not yet saturated. They occur in adequate concentrations to provide sufficient embryos.



(c). Squires (1955, 1958) sought the key to the problem in the nature of the main droplet population rather than in the generation of raindrop embryos. Observation revealed a systematic difference in general microstructure between maritime and continental cumuli; the latter being relatively "fine grained" with large concentrations of relatively small droplets. On the one hand, this difference was attributed primarily to the differing nature of the continental and marine aerosols; on the other, more elaborate computations of stochastic coalescence by Twomey (1966) and Berry (1967) show that this difference could explain the primarily maritime occurrence of warm rain.

The interaction of the three aspects of phenomena in nature--their "relative importance", for example--is far from clear. As regards modification attempts, (b) has given rise to the suggestion that rainfall could be increased by seeding with large hygroscopic particles, and an experiment near Delhi has given indications of encouraging results. On the other hand, (c) has given rise to the notion that rainfall could be reduced if large numbers of cloud nuclei were added to an air mass sufficiently far upwind. In this way, it is possible that excessive rainfalls on the Coast Range of Oregon could be reduced, a result which in itself could have some beneficial value, and which could conceivably result in increased snowfall in the high Cascades. However, very serious scientific and engineering difficulties stand in the way of a field test of this concept. These difficulties give special interest to the study of the effects of man-made air pollution on rainfall such as those reported by Warner (1968) or Changnon (1968).

#### IV. "Cold" Precipitation

The attempts so far made in the field to modify precipitation have, of course, all been based on the seeding of supercooled clouds to nucleate the formation of ice particles with the object of initiating the Wegener-Bergeron-Findeisen mechanism. Early experiments were made by dropping dry-ice pellets from aircraft, and some of them had quite convincing results. The major effort since has been based on the use of surface generators of silver-iodide aerosol, the test of success being a statistical comparison of a seeded target area with a non-seeded control area nearby. The control area provided an estimate of what precipitation would have fallen on the target if there had been no seeding. Various randomized cross-over schemes were devised to improve this estimate.

Problems which have by now been recognized in various experiments of this type include:

(1) In plan view, the trajectory of the aerosol across the earth's surface can be different from what one might expect. No doubt, in experiments conducted in mountainous country, there have been occasions when more silver iodide aerosol passed over the control area than the target.

(2) The diffusion of the aerosol up to cloud levels must vary greatly with location and weather type. In one experiment, at least, there is reason to suppose that the aerosol often crossed the target area while still essentially below cloud base level, so that any seeding effect could only occur further downwind.

(3) A desirable concentration of ice crystals to introduce appears to be of order 1 per liter, depending on temperature, etc. Too few will be inefficient, too many will result in competition among the ice particles, restricting their growth. In the extreme, where all the cloud droplets freeze, the result is merely an ice fog, the potential for precipitation formation having been lost.

It is clear that in most statistical experiments little attention was given to this fundamental question. The desirable seeding rate depends on temperature, liquid water content, rate of condensation, etc.; the rate achieved depends, among other things, on the background level of turbulence which will disperse the plume of aerosol at varying speeds on different occasions.

When silver iodide eventually nucleates ice formation, it seems probable that the release of latent heat, warming a typical cloud volume by some tenths of a degree C, will generate local small-scale circulation which will rather quickly disperse the aerosol throughout the cloud. The subsequent growth of snowflakes will depend on factors such as temperature, liquid water content, as well as perhaps the electrical field.

It has been suspected that in some situations, seeding by a particular technique might result in decreases instead of increases in precipitation. Grant and Mielke (1965) suggest that this occurs with the colder cloud systems passing Climax, Colorado (as judged by the 500-mb temperature). In an experiment in which it was decided in advance to stratify the results according to the 500-mb temperature, the analysis indicated increases of over 100% in snowfall at the warmer temperatures (-13° to -17°C) and a slight decrease at temperatures around -30°C.

Elliott (1969), in an experiment at Santa Barbara, reports overall increases of order 100% as a result of refraining from seeding cloud structures (stratocumulus) in which it is thought that seeding could well decrease precipitation, while seeding heavily convective structures in which the rate of condensation must be high.

#### V. Conclusion

The work of Grant and Elliott suggests that a modest increase in physical sophistication has produced a marked improvement in the results attainable. This gives encouragement to the view that further increases in understanding will yield still better results, or perhaps make it possible to extend the areas in which useful results are achieved, the emphasis in research will tend to move away from the purely physical problems underlying the technology to the area of social implications--the economic and legal aspects--and into disciplines related to the control and preservation of our environment, such as ecology.

#### VI. References

- Berry, E. X. (1967): J. Atmos. Sc. Vol.24, p. 688.
- Changnon, S. A. (1968): Bull. Am. Met. Soc. Vol 49, p. 4.
- Elliott, R. P. (1969): Personal communication.
- Grant, L. O. and P. W. Mielke (1965): Proc. 5th Berkeley Symposium on Mathematical Statistics and Probability, Vol. 5, p. 115. U. of Cal. Press, 1957.
- Squires, P. (1955): Tellus, Vol. 8, p. 443.
- Squires, P. (1958). Tellus, Vol. 10, p. 256.
- Telford, J. W. (1955): J. Meteor., Vol. 12, p. 436.
- Twomey, S. (1966): J. Atmos. Sci., Vol. 23, p. 405.
- Warner, J. (1968): J. Appl. Meteor., Vol. 7, p. 247.
- Woodcock, A. H. (1953): J. Meteor. Vol. 10, p. 362.

#### SUMMARY COMMENTS

Colonel Edward O. Jess  
Director of Aerospace Services  
Headquarters Air Weather Service

So many interesting, yes even exciting, ideas were expressed here this week that it would be presumptuous for any one person to attempt to adequately summarize them all. Frankly, in planning the agenda we were selfish enough to select those areas of discussion in which we know too little; areas in which great changes may occur during the '70s with considerable impact upon the military services. We invited the most eminent scientists irrespective of affiliation to speak and nearly all accepted. The result has been a most profitable exchange of ideas. Much of the information will be contained in the published Proceedings. We shall send a copy to each of you.

During the first session we heard that the copious amounts of raw data already available would increase even more in quantity; but of more importance, were going to increase in quality and variety and cover more completely the data-sparse areas of the Earth. The weather satellite will remain in the forefront in providing this improved intelligence but will share the limelight with some of the more neglected sources of data over remote areas: constant-level balloons, ocean buoys and aircraft reports. Significant breakthroughs are expected in data presentation. The customer will receive only what he needs in a computer-driven, real-time display of processed information on a query/response basis.

Experts who are fully cognizant of the tremendous problems inherent in simulating the general circulation, guardedly predicted some success in long-range weather forecasting out to 2 or even 3 weeks. We heard proponents of computer forecasting and exponents of the older man-centered conventional forecasting agree that the man-machine mix or more properly the man-computer mix will be the best mechanism for making short and medium-range predictions in the '70s.

Unfortunately the problems of the tropics -- both meteorological and political -- may still be with us in the '70s. We heard that more complete tropical observations were imminent and with better use of current data would lead to better understanding of small-scale tropical phenomena. This knowledge may be the key to unlocking the mysteries of tropical forecasting.

In our last session we learned that more and better-designed weather modification research is needed and planned for the '70s. It will provide the basic knowledge which we require to actively suppress hail and lightning -- to augment rain from warm clouds.

We are indeed grateful to the 200 and more people who joined us in these sessions. Their many enlightening comments from this podium, the discussion table, and from the floor, have crowned this meeting with success. Besides our sister services, the Army, Navy and Coast Guard, and within the Air Force, Cambridge Research Laboratories, we are grateful to the non-military agencies who strongly supported these meetings. These are NASA, ESSA including the Weather Bureau, RAND, National Science Foundation, NCAR, the Bureau of Reclamation and others.

On behalf of the AWS I wish to thank General Moorman for inviting us to use his facilities in the heart of this beautiful vacation land. His contact men, Maj Ron Tudor and Capt Bob DeMichaels, ably coordinated for the Academy while our Maj Don Hansen superbly managed this affair. It involved a tremendous effort; Val Descamps' and Don Hansen's numerous other committee men are due our heartfelt thanks. So ends the 1969 Technical Exchange Conference. We sincerely hope that you found it worthwhile and will plan to attend subsequent meetings.

Unclassified

Security Classification

DOCUMENT CONTROL DATA - R & D		
<i>(Security classification of title, body of abstract and indexing annotation must be entered when the overall report is classified)</i>		
1. ORIGINATING ACTIVITY (Corporate author)	2a. REPORT SECURITY CLASSIFICATION	
Hqs, Air Weather Service	Unclassified	
	2b. GROUP	
3. REPORT TITLE		
"Meteorological Resource and Capabilities in the '70s" - Proceedings of the 5th AWS Technical Exchange Conference, USAF Academy, 14-17 July 1969.		
4. DESCRIPTIVE NOTES (Type of report and inclusive dates)		
Proceedings of a Scientific Meeting.		
5. AUTHOR(S) (First name, middle initial, last name)		
[Robert D. Fletcher, et al.,] See table of Contents, 32 Authors		
6. REPORT DATE	7a. TOTAL NO. OF PAGES	7b. NO. OF REFS
October 1969	248	
8a. CONTRACT OR GRANT NO.	9a. ORIGINATOR'S REPORT NUMBER(S)	
	AWS TR 217	
b. PROJECT NO.		
c.	9b. OTHER REPORT NO(S) (Any other numbers that may be assigned this report)	
d.		
10. DISTRIBUTION STATEMENT		
This document is subject to special export controls and each transmittal to foreign governments or foreign nationals may be made only with approval of Hq, Air Weather Service.		
11. SUPPLEMENTARY NOTES	12. SPONSORING MILITARY ACTIVITY	
Contains 29 technical presentations, several introductions, personal reminiscences, and summary talks.	Results reported were supported by agencies with which the authors are affiliated.	
13. ABSTRACT		
Full length reports or summaries are given of 29 Technical Papers presented at the 5th AWS Technical Exchange Conference, held at USAF Academy, Colo., 14-17 July 1969. The general theme is "Meteorological Resources and Capabilities of the 1970's". Authors represented Air Force, Army, Navy, NASA, ESSA, USDA, NCAR, universities, and an airline. Subject areas include data-gathering systems (ground, air, satellite), communication, computation, and display systems, numerical weather prediction, automation and applied weather forecasting (man-machine mix), tropical meteorology, and weather modification.		

DD FORM 1 NOV 65 1473

248

Unclassified

Security Classification



**DEPARTMENT OF THE AIR FORCE**

**AIR FORCE COMBAT CLIMATOLOGY CENTER (AFWA)  
ASHEVILLE, NORTH CAROLINA 28801-5002**

19 April 2005

MEMORANDUM FOR DTIC-OQ

ATTENTION: LARRY DOWNING  
8725 JOHN J. KINGMAN ROAD  
FORT BELVOIR, VA 22060-6218

FROM: Air Force Weather Technical Library  
151 Patton Ave, Rm 120  
Asheville, NC 28801-5002

SUBJECT: CHANGE CLASSIFICATION AND DISTRIBUTION STATEMENTS

1. AD873241 – A model of ionospheric total electron content.
2. AD117710 – Constant-pressure trajectories.
3. AD265052 – List of translations on meteorology and atmospheric physics, vol.II.
4. AD284757 – List of translations on meteorology and atmospheric physics, vol.III.
5. AD862101 – Meteorological resources and capabilities in the '70's. Proceedings of the 5<sup>th</sup> AWS Technical Exchange Conference, Air Force Academy, 14-17 July 1969.
6. AD227459 – List of translations on meteorology and atmospheric physics, vol.I.

All the above documents need to be changed to "Approved for Public Release, Distribution Unlimited" please.

A handwritten signature in cursive script that reads "Susan A. Tarbell".

SUSAN A. TARBELL  
Librarian, Classified Custodian,  
DTIC Point of Contact

Attachment:

1. 6 copies of front covers